



# Telemotive Engineered SLTX Transmitter

---

Remote Crane Controls

---

## Instruction Manual



**MAGNETEK**  
MATERIAL HANDLING  
**TELEMOTIVE**

TCENGLTX-0 Rev. C    March 2010  
Part Number: 178-00900  
©Copyright 2010 Magnetek Material Handling

# **Table of Contents**

Your New Radio Remote and Service Information	p.2
Safety Information	p.3-8
2.1. Power “ON-OFF” Switch	p.9
2.2. E-STOP	p.9
2.3. Motion Push Buttons or Levers	p.9
2.4. Transmitter LED Indicator	p.9
2.5. Time-Out Timer	p.9
2.6. Key Switch (For Part 15 models not using active ESTOP, keyswitch disables power to transmitter circuitry only)	p.9
3.1. SLTX Transmitter Board Set-up Information	p.10
3.2. Setting Access Code (For units with no external code plug only)	p.10-11
3.3. Programming Switches	p. 11
3.4. 10K Series SLTX Programming Switches	p.11-12
3.5. To Check Data	p. 12
3.6. Battery Monitor	p.12
3.7. Analog Voltage Reference	p.12
3.8. Transmit LED	p.12
3.9. Batteries and Charger	p.13
3.10. Changing the Channel on the Part 15 Synthesized Transmitter	p.13
3.11. Channels and Frequency Designating by Count	p.13-14
3.12. Changing the Channel on the Part 90 VHF Synthesized Transmitter	p.14
3.13 Replacement Parts	p.15

## Your New Radio Remote

Thank you for your purchase of Magnetek's Telemotive® brand SLTX Radio Remote Crane Control. Magnetek has set a whole new standard in radio-remote performance, dependability, and value with this unique new line of belly box transmitters. Without a doubt, our Telemotive SLTX is the ultimate solution for having precise, undeterred, and safe control of your material.

If your product ever needs modification or service, please contact one of our representatives at the following locations:

### U.S. Service Information

For questions regarding service or technical information, contact **1-866-MAG-SERV (1-866-624-7378)**.

Magnetek Material Handling  
N49 W13650 Campbell Drive  
Menomonee Falls, WI 53051

**Telephone:** 800-288-8178

**Website:** [www.magnetekmh.com](http://www.magnetekmh.com)

**e-mail:** [info@magnetekmh.com](mailto:info@magnetekmh.com)

### Fax Numbers

*Main:* 800-298-3503

*Sales:* 262-783-3510

*Service:* 262-783-3508

### Canada Service Information:

2610 Dunwin Drive

Mississauga, Ontario

L5L 1J5 Canada

Phone: 1-800-792-7253

Fax: 1-905-828-5707

©2010 MAGNETEK MATERIAL HANDLING

All rights reserved. This notice applies to all copyrighted materials included with this product, including, but not limited to, this manual and software embodied within the product. This manual is intended for the sole use of the person(s) to whom it was provided, and any unauthorized distribution of the manual or dispersal of its contents is strictly forbidden. This manual may not be reproduced in whole or in part by any means whatsoever without the expressed written permission of MAGNETEK.

## PRODUCT MANUAL SAFETY INFORMATION

Magnetek, Inc. (Magnetek) offers a broad range of radio remote control products, control products and adjustable frequency drives, and industrial braking systems for overhead material handling applications. This manual has been prepared by Magnetek to provide information and recommendations for the installation, use, operation and service of Magnetek's material handling products and systems (Magnetek Products). Anyone who uses, operates, maintains, services, installs or owns Magnetek Products should know, understand and follow our instructions and safety recommendations in this manual for Magnetek Products.

The recommendations in this manual do not take precedence over any of the following requirements relating to cranes, hoists and lifting devices:

- Instructions, manuals, and safety warnings of the manufacturers of the equipment where the radio system is used,
- Plant safety rules and procedures of the employers and the owners of facilities where the Magnetek Products are being used,
- Regulations issued by the Occupational Health and Safety Administration (OSHA),
- Applicable local, state or federal codes, ordinances, standards and requirements, or
- Safety standards and practices for the overhead material handling industry.

This manual does not include or address the specific instructions and safety warnings of these manufacturers or any of the other requirements listed above. It is the responsibility of the owners, users and operators of the Magnetek Products to know, understand and follow all of these requirements. It is the responsibility of the owner of the Magnetek Products to make its employees aware of all of the above listed requirements and to make certain that all operators are properly trained. No one should use Magnetek Products prior to becoming familiar with and being trained in these requirements.

### WARRANTY INFORMATION

FOR INFORMATION ON MAGNETEK'S PRODUCT WARRANTIES BY PRODUCT TYPE, PLEASE VISIT [WWW.MAGNETEKMH.COM](http://WWW.MAGNETEKMH.COM).

## 1.1: WARNINGS and CAUTIONS

**Throughout this document WARNING and CAUTION statements have been deliberately placed to highlight items critical to the protection of personnel and equipment.**

WARNING – A warning highlights an essential operating or maintenance procedure, practice, etc. which if not strictly observed, could result in injury or death of personnel, or long term physical hazards. Warnings are highlighted as shown below:



CAUTION – A caution highlights an essential operating or maintenance procedure, practice, etc. which if not strictly observed, could result in damage to, or destruction of equipment, or loss of functional effectiveness. Cautions are highlighted as shown below:



**WARNINGS and CAUTIONS SHOULD NEVER BE DISREGARDED.**

The safety rules in this section are not intended to replace any rules or regulations of any applicable local, state, or federal governing organizations. Always follow your local lockout and tagout procedure when maintaining any radio equipment. The following information is intended to be used in conjunction with other rules or regulations already in existence. It is important to read all of the safety information contained in this section before installing or operating the Radio Control System.

## 1.2: CRITICAL INSTALLATION CONSIDERATIONS



### WARNING

PRIOR TO INSTALLATION AND OPERATION OF THIS EQUIPMENT, READ AND DEVELOP AN UNDERSTANDING OF THE CONTENTS OF THIS MANUAL AND THE OPERATION MANUAL OF THE EQUIPMENT OR DEVICE TO WHICH THIS EQUIPMENT WILL BE INTERFACED. FAILURE TO FOLLOW THIS WARNING COULD RESULT IN SERIOUS INJURY OR DEATH AND DAMAGE TO EQUIPMENT.

ALL EQUIPMENT MUST HAVE A MAINLINE CONTACTOR INSTALLED AND ALL TRACKED CRANES, HOISTS, LIFTING DEVICES AND SIMILAR EQUIPMENT MUST HAVE A BRAKE INSTALLED. FAILURE TO FOLLOW THIS WARNING COULD RESULT IN SERIOUS INJURY OR DEATH AND DAMAGE TO EQUIPMENT.

AN AUDIBLE AND/OR VISUAL WARNING MEANS MUST BE PROVIDED ON ALL REMOTE CONTROLLED EQUIPMENT AS REQUIRED BY CODE, REGULATION, OR INDUSTRY STANDARD. THESE AUDIBLE AND/OR VISUAL WARNING DEVICES MUST MEET ALL GOVERNMENTAL REQUIREMENTS. FAILURE TO FOLLOW THIS WARNING COULD RESULT IN SERIOUS INJURY OR DEATH AND DAMAGE TO EQUIPMENT.

FOLLOW YOUR LOCAL LOCKOUT TAGOUT PROCEDURE BEFORE MAINTAINING ANY REMOTE CONTROLLED EQUIPMENT. ALWAYS REMOVE ALL ELECTRICAL POWER FROM THE CRANE, HOIST, LIFTING DEVICE OR SIMILAR EQUIPMENT BEFORE ATTEMPTING ANY INSTALLATION PROCEDURES. DE-ENERGIZE AND TAGOUT ALL SOURCES OF ELECTRICAL POWER BEFORE TOUCH-TESTING ANY EQUIPMENT. FAILURE TO FOLLOW THIS WARNING COULD RESULT IN SERIOUS INJURY OR DEATH AND DAMAGE TO EQUIPMENT.

THE DIRECT OUTPUTS OF THIS PRODUCT ARE NOT DESIGNED TO INTERFACE DIRECTLY TO TWO STATE SAFETY CRITICAL MAINTAINED FUNCTIONS, I.E., MAGNETS, VACUUM LIFTS, PUMPS, EMERGENCY EQUIPMENT, ETC. A MECHANICALLY LOCKING INTERMEDIATE RELAY SYSTEM WITH SEPARATE POWER CONSIDERATIONS MUST BE PROVIDED. FAILURE TO FOLLOW THIS WARNING COULD RESULT IN SERIOUS INJURY OR DEATH OR DAMAGE TO EQUIPMENT.

## 1.3: GENERAL

Radio controlled material handling equipment operates in several directions. Cranes, hoists, lifting devices and other material handling equipment can be large, and operate at high speeds. Quite frequently, the equipment is operated in areas where people are working in close proximity to the material handling equipment. **The operator must exercise extreme caution at all times.** Workers must constantly be alert to avoid accidents. The following recommendations have been included to indicate how careful and thoughtful actions may prevent injuries, damage to equipment, or even save a life.

## 1.4: PERSONS AUTHORIZED TO OPERATE RADIO CONTROLLED CRANES

Only properly trained persons designated by management should be permitted to operate radio controlled equipment.

Radio controlled cranes, hoists, lifting devices and other material handling equipment should not be operated by any person who cannot read or understand signs, notices and operating instructions that pertain to the equipment.

Radio controlled equipment should not be operated by any person with insufficient eyesight or hearing or by any person who may be suffering from a disorder or illness, is taking any medication that may cause loss of equipment control, or is under the influence of alcohol or drugs.

## **1.5: SAFETY INFORMATION AND RECOMMENDED TRAINING FOR RADIO CONTROLLED EQUIPMENT OPERATORS**

Anyone being trained to operate radio controlled equipment should possess as a minimum the following knowledge and skills before using the radio controlled equipment.

### The operator should:

- have knowledge of hazards pertaining to equipment operation
- have knowledge of safety rules for radio controlled equipment
- have the ability to judge distance of moving objects
- know how to properly test prior to operation
- be trained in the safe operation of the radio transmitter as it pertains to the crane, hoist, lifting device or other material handling equipment being operated
- have knowledge of the use of equipment warning lights and alarms
- have knowledge of the proper storage space for a radio control transmitter when not in use
- be trained in transferring a radio control transmitter to another person
- be trained how and when to report unsafe or unusual operating conditions
- test the transmitter emergency stop and all warning devices prior to operation; testing should be done on each shift, without a load
- be thoroughly trained and knowledgeable in proper and safe operation of the crane, hoist, lifting device, or other material handling equipment that utilizes the radio control
- know how to keep the operator and other people clear of lifted loads and to avoid “pinch” points
- continuously watch and monitor status of lifted loads
- know and follow cable and hook inspection procedures
- know and follow the local lockout and tagout procedures when servicing radio controlled equipment
- know and follow all applicable operating and maintenance manuals, safety procedures, regulatory requirements, and industry standards and codes

### The operator shall not:

- lift or move more than the rated load
- operate the material handling equipment if the direction of travel or function engaged does not agree with what is indicated on the controller
- use the crane, hoist or lifting device to lift, support or transport people
- lift or carry any loads over people
- operate the crane, hoist or lifting device unless all persons, including the operator, are and remain clear of the supported load and any potential pinch points
- operate a crane, hoist or lifting device when the device is not centered over the load

- operate a crane, hoist or lifting device if the chain or wire rope is not seated properly in the sprockets, drum or sheave
- operate any damaged or malfunctioning crane, hoist, lifting device or other material handling equipment
- change any settings or controls without authorization and proper training
- remove or obscure any warning or safety labels or tags
- leave any load unattended while lifted
- leave power on the radio controlled equipment when the equipment is not in operation
- operate any material handling equipment using a damaged controller because the unit may be unsafe
- operate manual motions with other than manual power
- operate radio controlled equipment when low battery indicator is on



## WARNING

THE OPERATOR SHOULD NOT ATTEMPT TO REPAIR ANY RADIO CONTROLLER. IF ANY PRODUCT PERFORMANCE OR SAFETY CONCERNS ARE OBSERVED, THE EQUIPMENT SHOULD IMMEDIATELY BE TAKEN OUT OF SERVICE AND BE REPORTED TO THE SUPERVISOR. DAMAGED AND INOPERABLE RADIO CONTROLLER EQUIPMENT SHOULD BE RETURNED TO MAGNETEK FOR EVALUATION AND REPAIR. FAILURE TO FOLLOW THIS WARNING COULD RESULT IN SERIOUS INJURY OR DEATH AND DAMAGE TO EQUIPMENT.

### 1.6: TRANSMITTER UNIT

Transmitter switches should never be mechanically blocked ON or OFF. When not in use, the operator should turn the transmitter OFF. A secure storage space should be provided for the transmitter unit, and the transmitter unit should always be placed there when not in use. This precaution will help prevent unauthorized people from operating the material handling equipment.

Spare transmitters should be stored in a secure storage space and only removed from the storage space after the current transmitter in use has been turned OFF, taken out of the service area and secured.

### 1.7: PRE-OPERATION TEST

**At the start of each work shift, or when a new operator takes control of the crane, operators should do, as a minimum, the following steps before making lifts with any crane or hoist:**

Test all warning devices.

Test all direction and speed controls.

Test the transmitter emergency stop.

## 1.8: BATTERIES



### **WARNING**

KNOW AND FOLLOW PROPER BATTERY HANDLING, CHARGING AND DISPOSAL PROCEDURES. IMPROPER BATTERY PROCEDURES CAN CAUSE BATTERIES TO EXPLODE OR DO OTHER SERIOUS DAMAGE. FAILURE TO FOLLOW THIS WARNING COULD RESULT IN SERIOUS INJURY OR DEATH AND DAMAGE TO EQUIPMENT.

## 1.9: BATTERY HANDLING

Use only batteries approved by Magnetek for the specific product.

Do not dispose of a battery pack in fire; it may explode.

Do not attempt to open the battery pack.

Do not short circuit the battery.

For intrinsically safe environments only use specified Magnetek Telemotive intrinsically safe batteries.

Keep the battery pack environment cool during charging operation and storage (i.e., not in direct sunlight or close to a heating source).

## 1.10: BATTERY CHARGING

For those transmitters equipped with battery chargers, please familiarize all users with the instructions of the charger before attempting to use.

Do not attempt to charge non-rechargeable battery packs.

Avoid charging partially discharged rechargeable batteries to help prolong battery cycle life.

Avoid charging the battery pack for more than 24 hours at a time.

Do not charge batteries in a hazardous environment.

Do not short the charger.

Do not attempt to charge a damaged battery.

Use only Magnetek Telemotive approved chargers for the appropriate battery pack.

Do not attempt to use a battery that is leaking, swollen or corroded.

Charger units are not intended for outdoor use. Use only indoors.

## 1.11: BATTERY DISPOSAL

Before disposing of batteries consult local and governmental regulatory requirements for proper disposal procedure.

## CAUTION

Before operating the transmitter, familiarize yourself with all safety information in this manual and any other local, state, or federal rules or regulations already in existence.

### **2.1: Power “ON-OFF” Switch (Turns transmitter and receiver ON and OFF).**

With the key switch (optional) engaged, pressing the ON/OFF push-button switch (Part 15) starts the transmitter, pushing it again starts the receiver; or toggling the ON/OFF toggle switch (Part 90) turns the transmitter and the receiver ON. If the transmitter is ON the BATT MONITOR light is ON or flashing. Pushing the ON/OFF button again (Part 15), or resetting the toggle switch to OFF (Part 90), will turn the transmitter and receiver OFF.

### **2.2: E-STOP (For Emergency Stopping only).**

When depressed, the MCR relay is opened, the receiver shuts down, and power to the equipment is immediately stopped. **Under normal operating conditions, the E-STOP must be in the raised position.** The transmitter must be turned OFF and ON again to restore normal operation. To be used for emergency stopping only, not for normal system shut down. The E-STOP will not function with the optional key switch turned OFF.

### **2.3: Motion Push Buttons, Levers.**

To activate motor functions, press and hold the push-button or lever that corresponds to the desired motion. The extent to which the push-button or lever is pushed, dictates the speed of the motor function.

### **2.4: Transmitter LED Indicator.**

The transmitter LED (red) indicates the transmitter is on, or transmitting, or has a low battery voltage. A slow flash rate indicates the unit is ON. A rapid flash rate indicates the unit is transmitting (when a function or control is activated). If the battery goes below a safe level, the LED will not light. Replace battery soon.

### **2.5: Time-Out-Timer.**

Unless this function is disabled, the transmitter will turn itself OFF if not used for 15 minutes.

### **2.6: Key Switch. (For Part 15 Models not using active ESTOP, disables power to transmitter circuitry only).**

For models so equipped, turning the key OFF and removing it will disable the transmitter. If the key switch is turned OFF with the transmitter and receiver on, the key switch must be turned ON again to use the on/off pushbutton or E-STOP. Turning the key switch to ON enables power to the transmitter unit, but does not activate the transmitter controls or turn ON the receiver. The ON/OFF push button must be pushed to turn the transmitter and receiver ON or OFF. Under normal procedures it is recommended that the unit be turned OFF with the ON/OFF push button before turning OFF the key switch.

### 3.1: SLTX Transmitter Board Setup Information.

The SLTX Transmitter Board is shown in Figure 3-1. Refer to paragraphs 3.1 through 3.6 for servicing procedures.

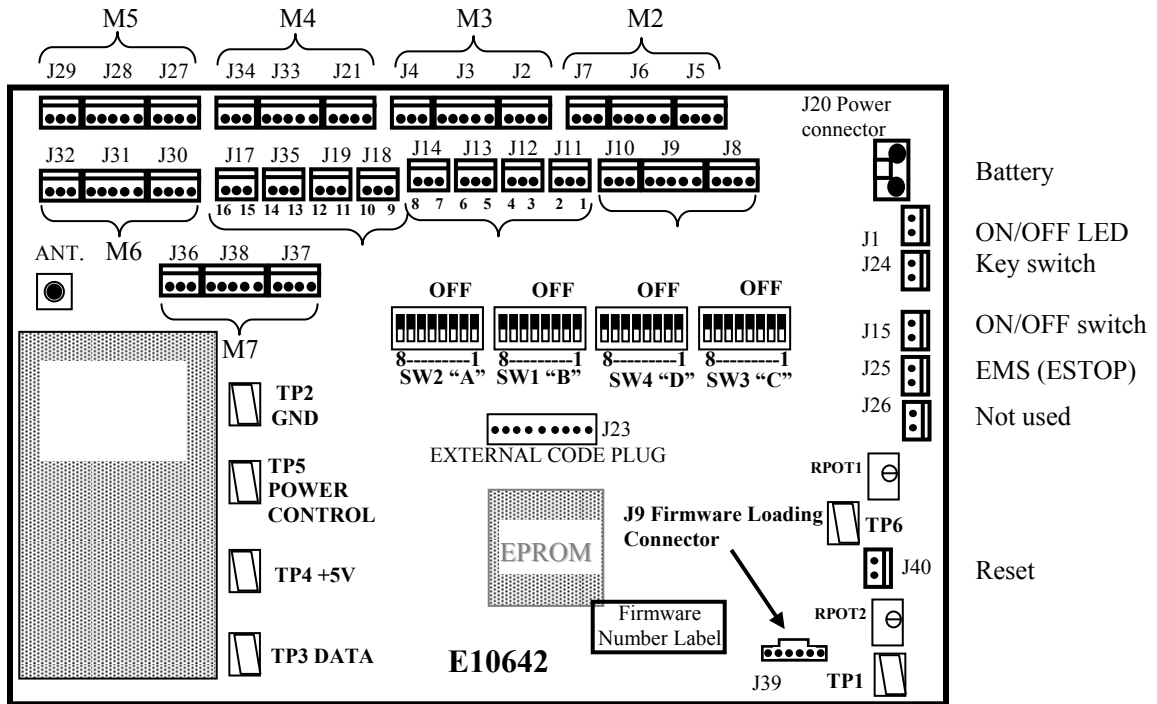

Figure 3-1. SLTX Transmitter Board E10642.

### 3.2: Access Codes Switches. (SW1 and SW2). Setting Access Code (for units with no external code plug only).

For Part 90 systems the 12 bit access code is assigned starting with position A1 through A8 then B1 through B4. For 8 bit access codes switch B is not used.

The access code is set at the factory and should not be changed unless absolutely necessary. If a spare transmitter unit is used, the receiver unit access code should be changed to match the access code of the spare transmitter unit. For Part 15 systems the access codes are printed on a white label on the outside of any transmitter and may be matched to "A" and "B" on the receiver CPU Board without having to open the transmitter housing.

Switch SW2 (B) in the transmitter must match switch (B) on the receiver CPU Board and switch SW1 (A) in the transmitter must match switch (A) on the receiver CPU Board.

If the codes do not match you will get an error light DS9 on the receiver CPU Board while transmitting.

If you are reprogramming a spare transmitter make sure the other transmitter is securely taken out of service.



## WARNING

TWO OPERATIONAL TRANSMITTERS WITH THE SAME ACCESS CODES OPERATING AT THE SAME TIME IS A DEFINITE SAFETY HAZARD. FAILURE TO FOLLOW THIS WARNING COULD RESULT IN SERIOUS INJURY OR DEATH AND DAMAGE TO EQUIPMENT.

Telemotive receivers are shipped with the access code settings for the transmitter marked on the receiver door.

Also a label on the transmitter lists the access code settings inside. The positions on the transmitter label match the switch settings. The “1” by A1 means the switch position A1 should be ”ON” and “0” means A1 should be “OFF”.



## WARNING

AFTER CHANGING THE ACCESS CODES ON THE TRANSMITTER, TEST THE UNIT BY TURNING IT ON AND OFF NEAR THE APPROPRIATE RECEIVER. IF THE RECEIVER DOES NOT RESPOND, DO NOT ACTIVATE A FUNCTION BUTTON! THE TRANSMITTER MAY HAVE THE WRONG ACCESS CODE, WHICH COULD MOVE ANOTHER CRANE. RE-CHECK THE ACCESS CODE IN THE TRANSMITTER AND RETEST. FAILURE TO FOLLOW THIS WARNING COULD RESULT IN SERIOUS INJURY OR DEATH AND DAMAGE TO EQUIPMENT.

### 3.3: SLTX Programming Switches.

The programming switch SW3 controls the following features: *(These only apply to units originally programmed to utilize these features).*

External Code Plug Enable – Switch SW3-position 1 turn “ON” to enable external code plug.

Time-Out-Timer Disable – Switch SW3-position 8 turn “ON” to disable transmitter time-out timer.

Active E-STOP – Switch SW3-position 5 turn “ON” to enable Active E-STOP.

### 3.4: 10K Series SLTX Programming Switches SW3 and SW4 Programming.

#### 1) Transmitter programming SW3.

- a) **Positions 1-7 (Keep turned “OFF”).**
- b) **Position 8 Time-out-timer Disable. (Normally keep turned “OFF”).**

The transmitter has an approximate 15-minute time-out-timer. If the transmitter is not used for over 15 minutes it will shut down. This transmitter time-out-timer function is transmitter dip switch selectable. SW3 position 8 disables the time-out-timer. Turning SW3-8 “ON” disables the time-out-timer.

#### 2) Transmitter programming SW4.

- a) **Position 1-2 Mode Enable. (Standard Mode 1, keep 1-2 turned “OFF”).**

Mode 1, SW4 1-2 all “OFF”. The 10K12 single speed system comes standard configured this way from the factory with three motion controls and six auxiliaries (controlled by the toggle switches). The 10K12 2-speed system comes standard configured this way from the factory with three 2-speed controls and three auxiliaries (controlled by the toggle switches; the rotary is non-functional).

Mode 2, SW4 1 turned “OFF” and SW4 2 turned “ON”. The 10K12 2-speed system configured this way is able to control four 2-speed motion controls and no auxiliaries. This gives you bridge, trolley, main and aux hoist. The rotary selector switch functions are H1 main hoist, H2 aux hoist and B both main and aux hoist (the toggle switches are non-functional).

Mode 3, SW4 1 and 2 turned “ON”. The 10K12 2-speed system will control up to 5 motors using the rotary selector switch. This mode reconfigures two of the 10K12 auxiliary outputs (Aux 1 and Aux 2) to be external motor select functions by the rotary switch. In this mode the auxiliary toggle switches Aux 1 and Aux 2 are disabled. When the rotary switch is in the H1 or H2 position Aux 1 relay or Aux 2 relay will pull in respectively whenever trolley or hoist pushbuttons are pressed. When the rotary switch is in B position both Aux 1 and Aux 2 relays will pull in.

**b) Position 3 Disable Tandem for Hoist and Trolley. (Normally keep turned “OFF”).**

For cranes with auxiliary hoists and/or trolleys, turning this switch “ON” disables the transmitter selector switch “B” position (BOTH function) that selects tandem operation of hoist or trolley.

**c) Position 4 Invert Crane Select Aux. Outputs. (Normally keep turned “OFF”).**

For cranes that use the select function only, turning this switch “ON” inverts the select function operation so that the relay closes for the unselected function.

**d) Positions 5-7 Extended Crane Control Configurations. (Standard all “OFF”, otherwise see the appropriate receiver manual).**

The 10K12/18 SLTX transmitter is available with extended crane control configurations. These options are switch configurable on the transmitter. The eight-position dip switches SW3 and SW4 on the transmitter can provide all configurations with a single transmitter CPU EPROM for the 2-speed transmitter. See your receiver manual for available configurations and the switch programming needed to provide them.

**e) Position 8 No Function (keep turned off).**

**3.5: To Check Data.**

- 1). For data input use Data pin on RF Module.
- 2). Use RF SW pin on RF Module for External Trigger input.
- 3). Use TP2 for Ground.

**3.6: Battery Monitor.**

Set to 5.8 Volts by R6 and R8 not adjustable.

**3.7: Analog Voltage Reference.**

Controls lever range, V+ (TP1) factory adjusted with RPOT2 (zero adjust) V- (TP6) factory adjusted with RPOT1 (full scale adjust).

**3.8: Transmit LED.**

This flashing red LED flashes rapidly during transmit, slowly when unit is ON and turns out when battery is low.

### 3.9: Batteries and Charger.

Three batteries are available, a disposable alkaline battery BT120-0, a rechargeable 7.2V NiMH (BT122-0), and a rechargeable 12V NiMH (BT123-0). The single battery charger for the BT122-0 and BT123-0 is the E10759-0. Two piggyback chargers (E10759-1) can be used with one E10759-0. Please see your charger manual for additional details. Please follow local regulations for the disposal of any battery product.

### 3.10: Changing the Channel on the Part 15 Synthesized Transmitter.

The channel can be changed by removing the logic board from the bottom housing. Locate the rotary switches on the RF Transmitter Board (see Figure 4-1 SLTX Synthesizer Board). The rotary switch nearest the corner of the board is the “ones” place-value selection (0-9). The rotary switch near the middle of the board is the “tens” place-value selection (10, 20, and 30).

**Figure 4-1 SLTX Synthesizer Board**

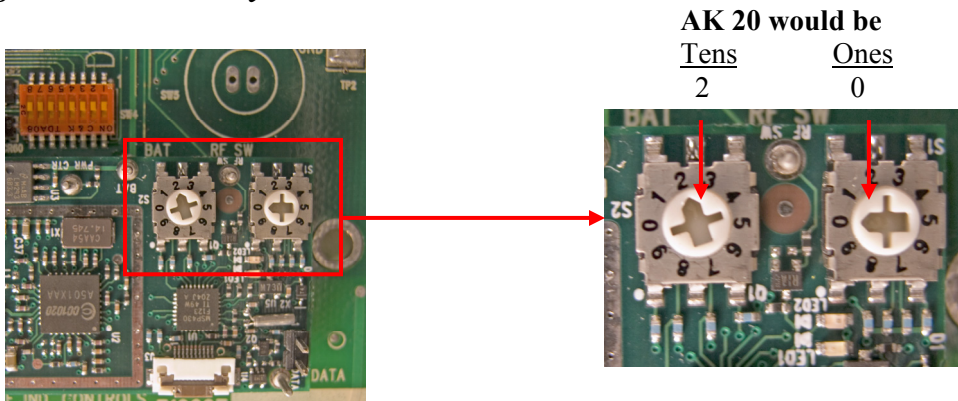

### 3.11: Channel and Frequency Designations by Count

Indicator Count	Channel Designator	Actual Frequency
01.	AK01	439.8 MHz
02.	AK02	439.6 MHz
03.	AK03	439.4 MHz
04.	AK04	439.2 MHz
05.	AK05	439.0 MHz
06.	AK06	438.8 MHz
07.	AK07	438.6 MHz
08.	AK08	438.4 MHz
09.	AK09	438.2 MHz
10.	AK10	438.0 MHz
11.	AK11	437.8 MHz
12.	AK12	437.6 MHz
13.	AK13	437.4 MHz
14.	AK14	437.2 MHz
15.	AK15	437.0 MHz
16.	AK16	436.8 MHz
17.	AK17	436.6 MHz
18.	AK18	436.4 MHz
19.	AK19	436.2 MHz
20.	AK20	436.0 MHz

#### Compliance Statement (Part 15.19)

This device complies with Part 15 of the FCC Rules. Operation is subject to the following two conditions:

1. This device may not cause harmful interference, and
2. This device must accept any interference received, including interference that may cause undesired operation.

#### Warning (Part 15.21)

Changes or modification not expressly approved by the party responsible for compliance could void the user’s authority to operate the equipment.

This portable transmitter with its antenna complies with FCC’s RF exposure limits for general population/uncontrolled exposure.

Indicator Count	Channel Designator	Actual Frequency
21.	AKA00	433.125 MHz
22.	AKA01	433.325 MHz
23.	AKA02	433.525 MHz
24.	AKA03	433.725 MHz
25.	AKA04	433.925 MHz
26.	AKA05	434.125 MHz
27.	AKA06	434.325 MHz
28.	AKA07	434.525 MHz
29.	AKA08	434.725 MHz
30.	AK38	432.4 MHz
31.	AK50	430.0 MHz

**3.12: Changing the Channel on the Part 90 VHF Synthesized Transmitter.**

The Part 90 VHF transmitter can be programmed for up to four different channels. The pre-programmed channels can be changed by moving the jumper to another channel. Please refer to the label on the transmitter board for the frequency of each channel.

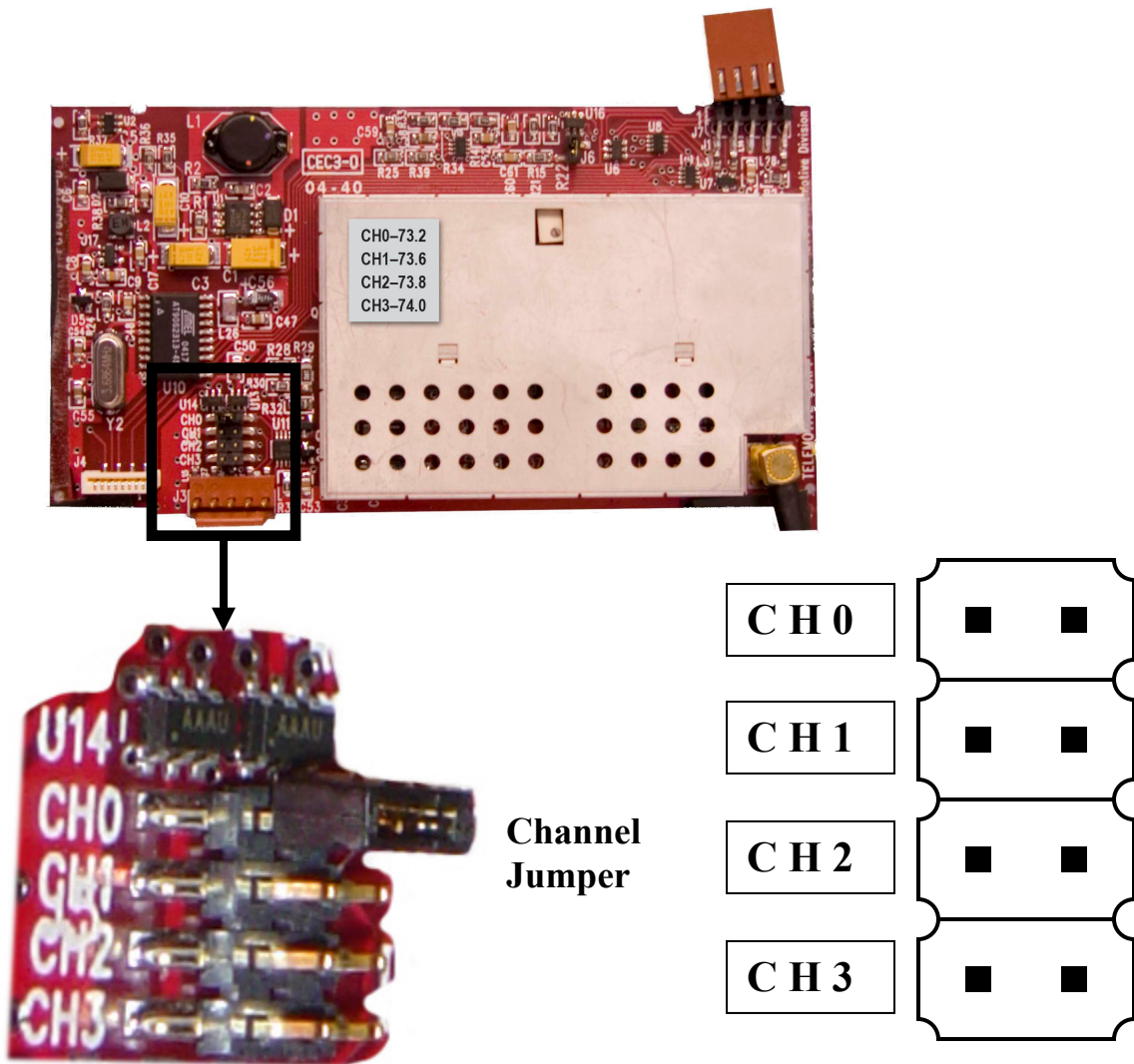

### 3.13: Replacement Parts.

If your transmitter ever needs repair, we always recommend that you contact Magnetek for servicing. If you need to refer to a parts list please refer to your transmitter's drawing that was included in the shipment of your transmitter. If you have trouble locating the drawing, the latest version is available on our web site at [www.magnetekmh.com](http://www.magnetekmh.com). For replacement batteries and chargers, your options are as follow:

#### **Battery and Charger**

9V Alkaline (disposable)	BT120-0
7.2V NiMH (re-chargeable)	BT122-0
12V NiMH (re-chargeable)	BT123-0
Charger BT122-0 and BT123-0	E10759-0
Piggyback Charger (2 per E10759-0)	E10759-1