

BUFFER TROLLEY LOCK-DOWN UNIT

Magnetek Material Handling

Radio Control System

Installation and Users Manual



Telemotive

TC10K-TR6 Rev. C January 2006

Part Number: 27714T

©Copyright 2006 Magnetek Material Handling

This page intentionally left blank.

Table of Contents

- 1- Service Information.....2
- 2- Radio Controlled Safety3
- 3- General System Information9
- 4- Installation Procedure.....11
- 5- Operation 14
- 6- Wiring Diagram.....18
- 7- Servicing and Programming.....21
- 8- Spare Parts.....29

Section 1 – Service Information

U.S. Service Information

For questions regarding service or technical information contact:

**1-866-MAG-SERV
(1-866-624-7378).**

Magnetek Material Handling
N49 W13650 Campbell Drive
Menomonee Falls, WI 53051

Telephone: 800-288-8178

Website: www.magnetekmh.com

e-mail: info@magnetekmh.com

Fax Numbers:

Main: 800-298-3503

Sales: 262-783-3510

Service: 262-783-3508

Canada Service Information:

2610 Dunwin Drive

Mississauga, Ontario

L5L 1J5 Canada

Phone: 1-800-792-7253

Fax: 1-905-828-5707

Section 2 – Radio Controlled Safety

2-1. Warnings, Cautions and Notes.

Through out this document **WARNING**, **CAUTION** and **NOTE** statements have been deliberately placed to highlight items critical to the protection of personnel and equipment.

WARNING – A warning highlights a essential operating or maintenance procedure, practice, etc. which if not strictly observed, could result in injury or death of personnel, or long term physical hazards. Warnings are highlighted as shown below:



CAUTION – A caution highlights an essential operating or maintenance procedure, practice, etc. which if not strictly observed, could result in damage to, or destruction of equipment, or loss of functional effectiveness. Cautions are highlighted as shown below:



NOTE – A note highlights an essential operating or maintenance procedure, condition or statement. Notes are shown as below:

NOTE

WARNINGS, CAUTIONS AND NOTES SHOULD NEVER BE DISREGARDED.

The safety rules in this section are not intended to replace any rules or regulations of any applicable local, state, or federal governing organizations. The following information is intended to be used in conjunction with other rules or regulations already in existence. It is important to read all of the safety information contained in this section before installing or operating the Radio Control System.

2-2. Critical Installation Considerations.

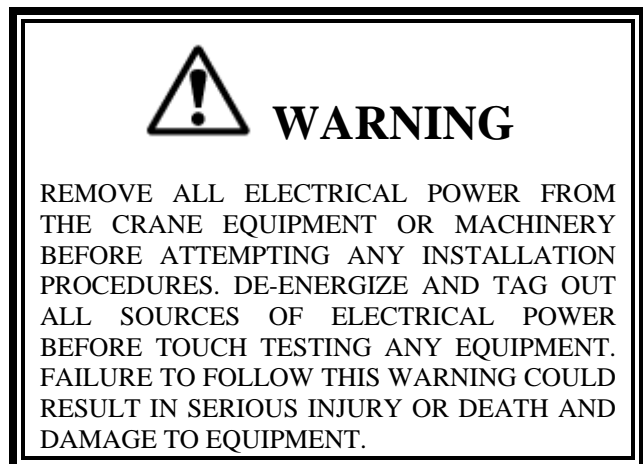
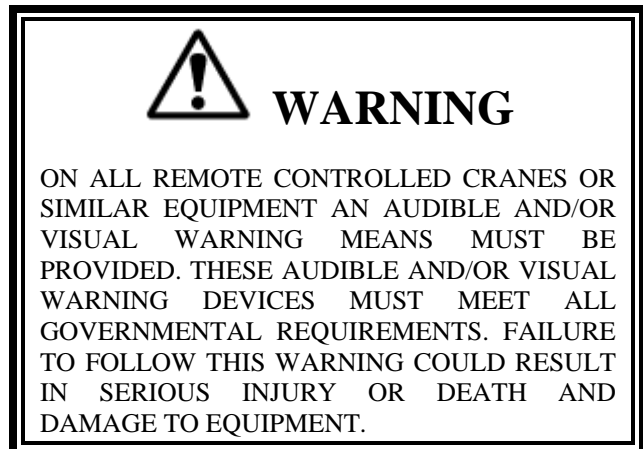
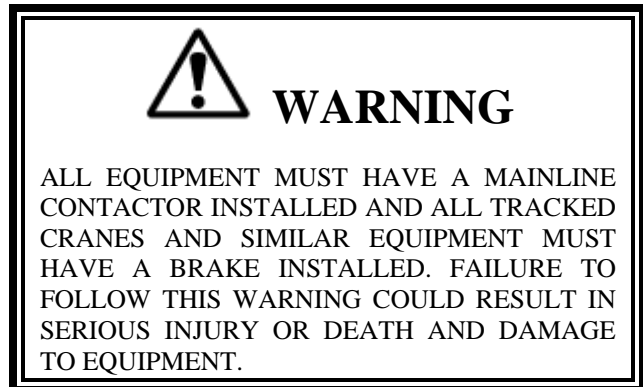

Section 2 – Radio Controlled Safety (Continued)



WARNING

THE DIRECT OUTPUTS OF THIS PRODUCT ARE NOT DESIGNED TO INTERFACE DIRECTLY TO TWO STATE SAFETY CRITICAL MAINTAINED FUNCTIONS, I.E., MAGNETS, VACUUM LIFTS, PUMPS, EMERGENCY EQUIPMENT, ETC. A MECHANICALLY LOCKING INTERMEDIATE RELAY SYSTEM WITH SEPARATE POWER CONSIDERATIONS MUST BE PROVIDED. FAILURE TO FOLLOW THIS WARNING COULD RESULT IN SERIOUS INJURY OR DEATH AND DAMAGE TO EQUIPMENT.

2-3. General.

Radio controlled overhead cranes and other equipment operate in several directions. They are large, bulky pieces of equipment that handle heavy loads efficiently at high speeds. Quite frequently, the equipment is operated in areas where people are working on the floor below. The crane equipment operator must exercise extreme caution at all times. Workers must constantly be alert to avoid accidents. The following rules have been included to indicate how your careful and thoughtful actions may prevent injuries, damage to equipment, or even save a life. If radio controlled material-handling equipment is operated from the cab, special care must be taken to secure the transmitter. Refer to section titled Section 2-9. Boarding The Crane Equipment for specific safety rules.

2-4. Persons Authorized To Operate Radio Controlled Crane Equipment.

Only properly trained persons designated by management should be permitted to operate radio-controlled crane equipment.

Radio controlled crane equipment should not be operated by any person who cannot read or understand signs, notices and operating instructions that pertain to the crane.

Radio controlled crane equipment should not be operated by any person with insufficient eyesight or hearing or by any person who may be suffering from a disorder or illness or is taking any medication that may cause loss of crane equipment control.

2-5. Training Checklist For Crane Equipment Operators.

Anyone being trained to operate radio-controlled crane equipment should possess as a minimum the following knowledge and skills before operating the crane:

The operator should have knowledge of hazards peculiar to crane equipment operation.

The operator should have knowledge of the safety rules for radio-controlled crane equipment.

The operator should have the ability to judge distance or moving objects.

The operator should have knowledge of the radio transmitter.

The operator should know the limit switch test procedure.

The operator should know, where authorized, instructions for plugging motions.

The operator should have knowledge of the use of crane equipment warning lights and alarms.

The operator should have knowledge of observing crane equipment signal lights.

The operator should be trained to avoid striking any obstructions.

The operator should have knowledge of the proper clearance of lifts or hooks before moving bridge or trolley.

The operator should have knowledge of the proper storage space for radio control box when not in use.

The operator should be trained in transferring radio control box to another person.

The operator should be trained how and when to report unsafe or unusual operating conditions.

The operator should be trained how to exhibit caution in approaching bridge or trolley bumpers.

The operator should know equipment capacity.

The operator should be trained in making lifts below floor level.

The operator should be trained in making side pulls.

Section 2 – Radio Controlled Safety (Continued)

The operator should know how to keep himself and other people clear of lifts and to avoid "pinch" points.

The operator should know cable and hook inspection procedures.

The operator should know procedures for testing hoist, trolley, and bridge brakes.

2-6. Operating Area.

Aisles between equipment, stock, etc., should be free of obstructions so the crane equipment operator can move freely. These aisles should be a minimum of meter wide, or meet local regulations.

Crane equipment operators should always position themselves for the best view of the crane equipment they are controlling. The crane equipment should never be operated blindly. The operator should stay as close to the crane equipment as possible. Operators should never position themselves in a "pinch" point.

2-7. Transmitter Unit.

Transmitter switches should never be mechanically blocked ON or OFF for any crane equipment motion. When not in use turn the transmitter OFF. A secure storage space should be provided for the transmitter unit and the transmitter unit should always be placed there when not in use. This precaution will prevent unauthorized people from operating the crane.

Spare transmitters should be stored in a secure storage space and only removed from the storage space after the current transmitter in use has been turned OFF, taken out of the service area and secured.

2-8. Operating The Crane.

2-8.1. Pre-operation Test.

At the start of each work shift, or when a new operator takes control of the crane, operators shall do as a minimum the following steps before making lifts with any crane equipment or hoist:

Test the upper-limit switch. Slowly raise the unloaded hook block until the limit switch trips. When checking limit switches the hoist should be centered over an area free of personnel and equipment.

Visually inspect the hook, load lines, trolley, and bridge as much as possible from the operator's

station; in most instances, this will be the floor of the building.

The bridge and trolley brakes should be tested. On transmitter units equipped with two or more speeds, use the "lowest" speed when testing braking devices.

When lifting maximum loads, the crane equipment operator should test the hoist brakes by raising the load a few inches from the floor. If the brakes do not hold, the load should immediately be lowered to the floor.

If provided, test the lower-limit switch.

Test all warning devices.

Test all direction and speed controls for both bridge and trolley travel.

Test all bridge and trolley limit switches, where provided, if operation will bring the equipment in close proximity to the limit switches.

Test the transmitter emergency stop.

Test the hoist brake to verify there is no drift without a load.

If any crane equipment or hoist that fails any of the above tests notify the supervisor and lock out and tag for repair.

2-8.2. General Rules For Operation.

Consult the crane equipment manufacturer, local and governmental regulations for complete rules of operation. In general the following rules apply to remotely controlled crane equipment:

The limit switches should never be used as a regular stopping device. They are intended to be protective devices.

Do not make lifts in excess of the equipment rated capacity.

The bridge and trolley should be centered directly over the load when the load is raised to prevent swinging when making lifts.

Crane equipment designed for this purpose and only with supervisor permission should make side pulls. When a lift is being made, the crane equipment operator should not be positioned in the line of travel. The crane equipment or hoist should be operated

Section 2 – Radio Controlled Safety (Continued)

from a position either to the side or opposite from the direction of travel.

When raising or lowering a load, proceed slowly and make certain the load is under control. Tag lines should be used for handling unusual lengths or bulky loads. Remove slack from chains or slings gradually. Make certain all personnel are clear before making a lift.

The crane equipment operator should keep all body parts away from the lift and should never be positioned under the lift.

Do not make a lift or move a load if anyone is in a location where they could be struck by the crane equipment or the load.

If the crane equipment operator is being helped, the crane equipment should not be moved until the helper signals they are clear of the crane equipment and its load.

When a load is hanging from the crane hook and the crane equipment is being moved, the crane equipment operator should sound all warning devices frequently.

Loads should not be carried over workers heads. If a worker is in the path of crane equipment travel, the crane equipment operator should stop the crane equipment and clear the area before proceeding.

Runway stops or other crane equipment should never be bumped into.

When moving the crane, the crane equipment operator should be sure that the hook block and attachments or cables would not catch on nearby equipment. Slings, chains, or cables should never be dragged along the floor.

Unless required for operator safety, gloves should not be worn when operating the transmitter unit.

All loose materials or parts should be removed from the load before starting the lift.

The crane equipment operator should always hoist lifts high enough to clear all equipment and workers.

The crane equipment operator should never permit anyone to ride on the load or hook except when authorized by the supervisor.

When another crane on the same runway is stationary with a load hanging, the crane equipment operator

should maintain a safe distance between the stationary crane equipment and the one under their control.

Never leave suspended loads unattended. In an emergency, if the crane equipment is inoperative and a load suspended, notify the supervisor immediately, barricade and post signs on the floor beneath crane equipment and load.

If power to the crane equipment is removed, the crane equipment operator should turn the transmitter unit OFF and keep it OFF until power is restored.

If the crane equipment fails to respond properly, the crane equipment operator should stop operation, turn the transmitter unit OFF and immediately report the condition to their supervisor.

Outdoor crane equipment, which are subject to movement by wind, should be securely anchored when left unattended. If the crane equipment is equipped with bridge brakes, the parking brake should be set immediately.

2-9. Boarding The Crane Equipment.

The crane equipment should not be boarded without permission of the supervisor.

The crane equipment operator should turn off the transmitter and take it with them when boarding the crane.

If more than one person is boarding the crane, one person should be made responsible for ensuring all personnel are off the crane equipment before the system is returned to operation.

2-10. Crane Equipment Maintenance and Repair.

Qualified personnel must maintain a regularly, i.e., such as monthly, scheduled crane equipment inspection. During this crane equipment inspection the functionally and safety of the crane equipment remote control must also be tested. The inspection shall include, but be not limited to items listed in Section 2-12. Condition Of The Radio Controlled Crane Equipment. Consult crane equipment manufacturer, local and governmental regulations for recommended inspection intervals and proper inspection procedures. Problems noted during this inspection must be repaired before using the crane equipment or the remote control.

Minor repairs include routine maintenance and repairs such as greasing, cleaning and control

Section 2 – Radio Controlled Safety (Continued)

troubleshooting. All other repairs should be considered major. If the repair crew consists of more than one person, one person should be designated as the repair crew leader with the following responsibilities. If the repair crew consists of only one person, that person has the following responsibilities:

For minor repairs warning signs should be placed on the floor beneath the crane equipment or suspended from the crane. For major repairs, the floor area below the crane equipment should be roped off.

When major repairs are to take place, all persons operating other crane equipment on the same or adjacent runways, if any, must be notified prior to starting repairs. Notification should include the nature of the repair, safeguards provided, and movement limitations while repairs are in progress.

When practical, radio controlled crane equipment which cannot be moved during repairs must be protected against being bumped by other crane equipment on the runway. Bumpers should be installed on the exposed side or sides of the crane equipment under repair. They should be placed as far away as possible. The location of these bumpers should be indicated by red lights placed so that they are clearly visible to other crane equipment operators traveling on the same runway. When it is not possible to use bumpers, red lights must be placed so they are clearly visible to other crane equipment operators traveling on the same runway to indicate the restricted travel zone. All crane equipment operators on the same runway must be informed of the repair effort and thoroughly instructed to what their operations are limited to and informed they will be notified when repairs are completed.

If any hazard involving the repairmen exists when there is a runway adjacent to the crane equipment under repair, the adjacent runway should be blocked off as described above. When it is necessary to continue crane equipment operation on the adjacent runways warning lights must be installed and be visible to operators of crane equipment on those runways. All crane equipment should come to a complete stop prior to entering the restricted area and should proceed through this area only after receiving permission from a signal person designated for this purpose. Access of persons to and from the crane equipment being repaired should be under control of the repair crew leader.

When boarding the crane, the transmitter should be turned OFF and the transmitter should remain with

the repair crew leader. The leader should board the crane equipment first, open and lock out the main switch, and then signal the other members of the crew it is safe to board the crane.

If work on the crane equipment is to be done in areas not protected by standard handrails, the repair crew should wear approved safety belts.

All tools and equipment should be moved onto the crane equipment by the use of hand lines. The tools and equipment should be adequately secured to the hand lines.

If it is necessary to have the crane equipment control circuits energized, all power circuits for crane equipment movement must be opened prior to energizing the control circuits.

All personnel and tools should be moved to a safe spot before moving the crane equipment during repairs.

Headroom is at a minimum in some crane cabs and on some crane equipment walkways. Caution should be exercised when boarding or working on crane equipment. Hard hats should be worn whenever possible.

When repairs are finished, all personnel, tools and repair equipment should be removed before energizing the crane equipment circuits.

2-11. Using The Crane Equipment As A Work Platform.

When the crane equipment is to be used as a stationary work platform, follow all rules provided in Section 2-10. Crane Equipment Maintenance and Repair. When it is necessary for the crane equipment to be moved from time to time, the crane equipment operator should board the crane equipment with the transmitter unit. The crane equipment operator should ensure all personnel working on the crane equipment are in a secure position before moving the crane equipment to the next workstation. It should also be the crane equipment operators responsibility to ensure the main switch is open and locked down before work is resumed.

Section 2 – Radio Controlled Safety (Continued)



WARNING

THE CRANE EQUIPMENT OPERATOR SHOULD NOT ATTEMPT TO REPAIR ANY OF THE ITEMS STATED BELOW. THE CRANE EQUIPMENT CONDITION SHOULD BE REPORTED TO THE SUPERVISOR. FAILURE TO FOLLOW THIS WARNING COULD RESULT IN SERIOUS INJURY OR DEATH AND DAMAGE TO EQUIPMENT.

2-12. Condition Of The Radio Controlled Crane Equipment.

If the crane equipment fails to respond properly, the crane equipment operator(s) should notify their supervisor. When serious conditions are noticed (conditions that make the crane equipment unsafe to operate), the crane equipment should be shut down immediately and the supervisor notified. The following is a list of some of the items that should be included in the report. (See the crane equipment manufacturer for specifics and possible additional items):

Condition of hoisting cable and hook block (broken strands, clipped sheave wheels, etc.).

Condition of brakes (hoist, trolley, and bridge). (no bluing, rivets on shoes showing, glazing, etc.).

Condition of trolley and rail stops.

Condition of bridge structure.

Condition of festoon system.

Broken welds in any part of the crane equipment structure.

Proper fluid levels and lubrication.

Condition of bridge and trolley stops.

Carbon dust or signs burning on the covers of motors.

Indication of fluid, oil or grease leaks.

Condition of rail sweeps.

Walkways required handrails and ladders are in place, sturdy and not loose.

Protective guards are in place for all moving parts.

Alignment of bridge (screeching or squealing wheels indicate bridge is out of line).

Broken, cracked, or chipped rails on trolley or runway.

Condition of limit switches.

Condition of electrical and mechanical control (electrical or mechanical defects which cause faulty operation such as un-commanded stopping or starting of any crane equipment motions, warning devices, lights, or auxiliary functions).

Condition of gears (grinding or squealing may indicate foreign materials in gear teeth or a lack of lubrication).

All controls especially E-STOPS are in place and in working order.

Frequent relay tripping of power circuits.

Mechanical parts loosened by vibration (loose rivets, covers, bolts, etc.).

Uneven riding (worn or damaged wheels).

Condition of collector shoes or bars.

Condition of warning or signal lights and horns. (burned out or broken).

2-13. Battery Disposal.

Before disposing of batteries consult local and governmental regulatory requirements for proper disposal procedures.

Section 3 – General System Information

3-1. General System Information.

The Telemotive Radio Control System (system) provides remote control of overhead crane equipment using radio signals. The system consists of a hand held portable battery operated transmitter unit and a fixed station receiver unit.

A unique 16-bit code (Access Code) for each system is preset in receiver. The receiver considers any received signal, which does not match the receiver access code setting, invalid.

Up to four systems may be used with the same frequency in a 600-foot area (220 meters) at the same time. Each transmitter operating on the same frequency may be operated in close proximity, not less than six feet (1.9 meters), to each other.

3-2. TMS Low Power Signaling.

TMS (Time Multiplexed Signaling) is a Telemotive propriety high-speed packet data system. The system software is structured to minimize "on the air" transmission time of any transmitter. This allows for multiple transmitters to share a common frequency. The TMS system is designed so that a transmitter will send a signal for a predetermined ON time, and then will turn OFF. The length of transmitter ON time is referred to as data burst or packet. The packet length is a function of the quantity of data to be sent, and the data rate (baud). Once the packet is sent, the transmitter will turn OFF. This allows for other transmitters to time-share the same frequency when a transmitter has turned OFF. The TMS system software determines the OFF period and repetition rate of the ON period. Since each system has its own access code, up to 4 transmitters can share and have equal access to the same frequency. TMS also allows for reduced battery consumption and extended battery life.

These systems have low power pulsed signaling, FCC certified under Part 15 Telecommunications Code of Regulations, no license is required. The transmitter unit is frequency modulated, low power and is certified under the appropriate regulations. A license is not required for the transmitter or operator.

3-3. Receiver Unit.

The receiver unit consists of an RF receiver module, built in antenna with filter, integral power supply, microprocessor controlled output motor control and auxiliary function relays and mainline contactor relay. The receiver unit contains circuitry, which

matches the frequency and access code of the transmitter. The receiver unit is completely contained in a cabinet is weather and dirt resistant. The receiver unit is turned ON or OFF by direct command of the transmitter. The commands sent by the transmitter control the relays.

A power down feature allows the receiver unit to turn OFF if no commands are received for approximately 15 minutes. The transmitter unit must again be turned ON to reactivate the receiver. When the receiver is turned OFF the mainline contactor is opened. The receiver can be programmed to not time out see Section 7. Service and Programming for information on time out disable.

3-4. Receiver Housing.

Size: 10.95" high x 7.5" wide x 5.12" deep
(280mm x 190mm x 130mm).

Housing rating:

USA: NEMA 4, 4X, 12, 13; UL 94-HB

EURO: IP67, IEC 529

3-5. System Specifications.

Channel Designation: AK01: 439.8 MHz.

Antenna: Internal with built in band pass filter. (optional external available).

Operating Temperature: -22°F to +158°F
(-30°C to +70°C) ambient.

Humidity: up to 95% (non-condensing).

Typical Operating Range: 200 feet (60 meters).

Output relays are rated at 16 Amps 250 VAC, but fused at 10 amps for safety.

3-6. Transmitter Unit.

The transmitter is battery operated has an ON and OFF switch, E-STOP, motor controls and auxiliary controls used for such item warning indicators.

An LED mounted on the front panel provides battery voltage, ON/OFF indication and data transmission status.

A power down feature allows the transmitter and the receiver unit to turn OFF if no keys are pressed for approximately 15 minutes. The transmitter unit must again be turned ON. The unit uses pulsed operation

Section 3 – General System Information (Continued)

for extremely long battery life. The transmitter can be programmed to not time out see Section 7. Service and Programming for information on time out disable.

Housings are designed of high impact, chemical resistant, materials. The antenna for the unit is internal. A strap or belt is provided for carrying the transmitter.

Section 4 – Installation Procedure

4-1. Pre-Installation Considerations.

To ensure reliable and safe operation of the system, the following items must be considered before installing the receiver unit.

If the receiver is mounted outdoors or in a corrosive environment, the receiver unit cabinet must be housed in a protective enclosure.

The receiver unit should not be subjected to moisture.

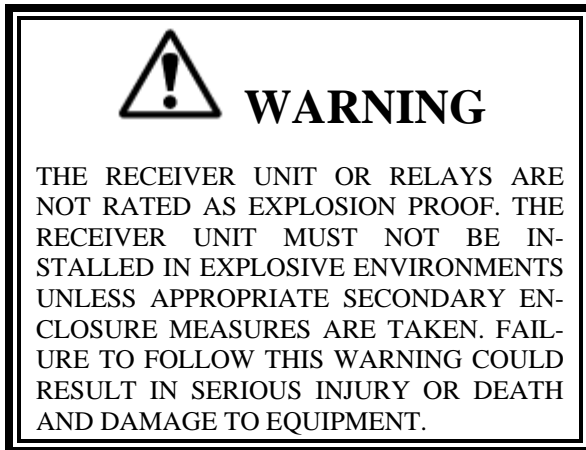

4-2. Receiver Unit Mounting Location Considerations.

Ensure the mounting location is as far as possible from exposed trolley wires and sources of electromagnetic or radiated noise

The receiver unit requires a mounting area approximately 8" (20 cm) wide by 11" (28 cm) high. A depth of at least 6" (15 cm) must be provided to allow the cabinet door to open.

The mounting surface must be smooth and continuous. Mounting the cabinet on uneven surfaces could cause warpage or stress internal components.

The receiver unit may be mounted in any position. Greatest radio control range is obtained when the receiver unit is mounted with the antenna pointed straight up.

If possible, avoid installing receiver unit to a surface where high vibration or shock is present. If this cannot be avoided, use appropriate shock mounts.

4-3. Antenna Mounting Considerations.

The antenna is internal and requires no additional mounting. The antenna is at the top of the receiver cabinet and should not be placed near large metal objects that could be close to or cover the top of the box. Allow at least six inches above the top of the box for clearance.

4-4. Line Input Considerations.

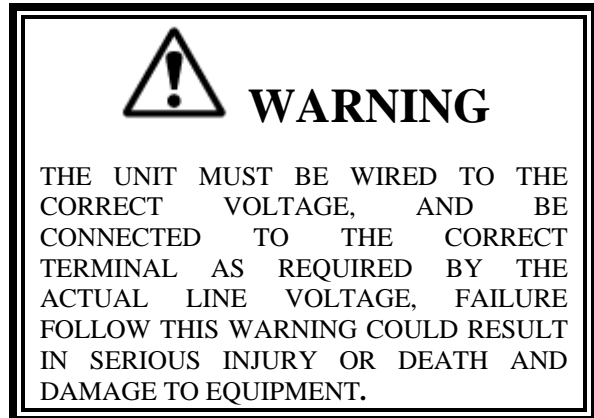

The receiver unit has direct connect provisions for operation from 120 (nominal), 50-60 Hz power.

For applications where line voltage deviation exceeds 20% of nominal values if line voltage is not between

95-130 VAC or 190-260 VAC or if 440 VAC power is used, a step up or step down transformer must be used.

NOTE

THE RECEIVER UNIT SHOULD NOT BE CONNECTED TO LINES CONTAINING EXCESSIVE POWER UP TRANSIENTS OR CONTINUOUS COMMUTATOR NOISE. A LINE CONDITIONER MAY BE NECESSARY IN SOME INSTALLATIONS.

4-5. Wiring Considerations.

1. Read this manual before installation.
2. Please observe appropriate local and National Electrical Codes when wiring electrical devices.

Section 4 – Installation Procedure (Continued)

3. Do not connect or disconnect wiring, or perform circuit checks while the power is turned on.
4. The motor wiring should be in a separate metal conduit from the power wiring, which should also be in metal conduit.
5. Low voltage wires shall be wired with proper low voltage class wiring procedures.
6. Control wiring as well as antenna wiring shall be in separate conduit and shall be kept as short as possible.
7. All terminals shall be tightened to specified terminal torque 4.4 IN-LBS (.5 N·m). unless otherwise specified.
8. Remove excess metal screws, metal filings and wire clippings from inside of unit.
9. Inspect to make sure no exposed wire has contact with any other wiring or terminals.
10. Suppressors are strongly recommended on all contactors.

4-6. Receiver/Equipment Interface Considerations.

All output relay contacts are rated at 16 amps 250 VAC, however the system rating for the contacts is 5A. Connection to equipment or contactors with higher voltage or current requirements will require intermediate relays.

All relay outputs are normally open, momentary contact. Since a relay closure is only active while the transmitter unit key is pressed and held, devices such as lights or lifting magnet must use a mechanical auxiliary latching relay.

NOTE

FOR INFORMATION ON INTERFACING WITH SYSTEMS WITH HIGH IMPEDANCE INPUTS SEE SECTION 6-4. CONNECTING OUTPUTS TO DRIVES OR CONTACT TELEMOTIVE.

4-7. Receiver Unit Cabinet Mounting.

Mounting hardware is provided. See next page Figure 4-1A. Installation Hardware. The door is not attached when the unit is shipped to make it

easier to install the mounting screws. After the unit is mounted the door should be attached.

Mount receiver unit cabinet securely to mounting surface. Actual cabinet mounting dimensions and a mounting template are shown on page 29 Figure 4-2.

4-8. Receiver Installation.

1. Set the Access code per the instructions on pages 24-25 Section 7. Servicing and Programming
2. Position the receiver. Locate as far as possible from exposed trolley wire and sources of electromagnetic or radiated noise. Cabinet mounting dimensions and mounting template is on page 29 Figure 4-2. Antenna at top of unit should be kept as clear as possible of any metal object.
3. Mount the receiver. Through the four deep mounting holes in corners of the receiver housing use quantity four #10-24 slotted round head screws 1" in length, four #10 lock washers and four #10-24 hex nuts. Lock washers should be used in front of hex nuts. (Five sets of mounting hardware are provided; one set is a spare). See Figure 4-1A. Installation Hardware.
4. Attach door. Put two door screws in door. (Included in your unit are two pairs of door screws. One pair slotted and one pair wing head.) Pick the screws that are preferred, line up the slots in the door holes with the tapered part of the screw tip and firmly press the screws through the holes in the door until they snap through. (Lightly tapping them with a hard object will help to snap them in). Use the special door hinge screwdriver provided to screw in the door hinges to the main box. See Figure 4-1A. Installation Hardware.
5. Wire the unit using the appropriate electrical drawings for the specific transmitter and crane equipment orientation selected on pages 17-19 Section 6. – Wiring Diagrams. For crane equipment orientation determine if the direction pair Forward or Reverse better describes the equipment movement. Use this pair to wire the motor directionals respectively. Make sure to replace connectors in the correct locations).

Section 4 – Installation Procedure (Continued)

6. Wire the power to J1 input power connector. The connections are Ground (GND), Neutral (N) and 120 VAC 50-60 Hz (120V). See Figure 4-1B. Input Power Connections.
7. Wiring of the system should now be complete.
8. Stand clear of the crane equipment and apply AC power to receiver unit. Turn switch SW2 OFF (MR relay control) and SW1 ON (main power switch). Check to see if three green LEDs are lit (DS22, DS23 and DS24). If none are lit check AC power, power switch SW1 and fuse.
- 9.

Turn transmitter ON. Check to see if the yellow LED is now lit (DSMR1). At this point the MR relay is disabled, the functions of the transmitter can be checked by noting the turning ON of the appropriate red LEDs next to the control relays (DS7 to DS11). After checking out the functions, turn switch SW2 ON to enable the MR relay, check function and direction by jogging each motion. Now Installation should now be complete.

10. If there are any problems see pages 20-23 Section 7. – Servicing and Programming.

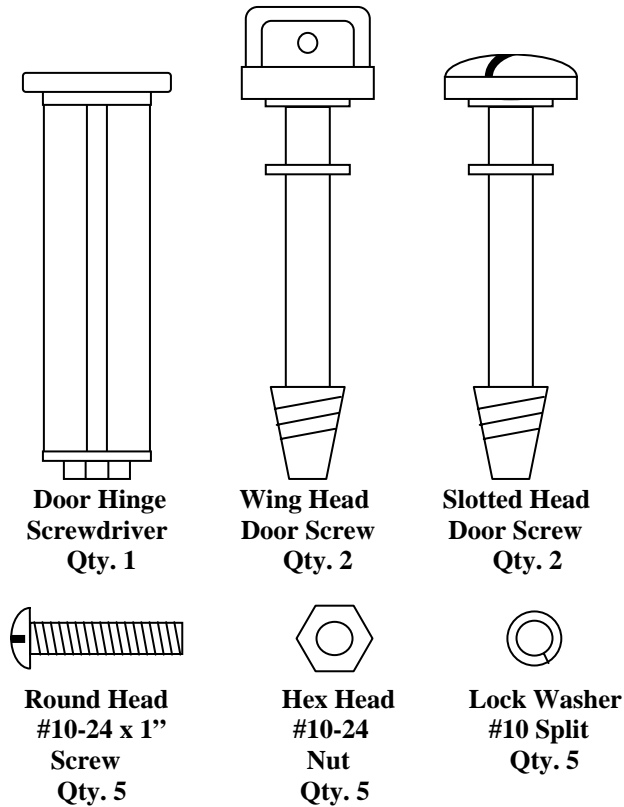

Figure 4-1A. Installation Hardware.

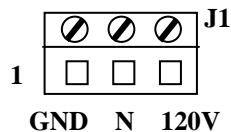

Figure 4-1B. Input Power Connections.

Section 5 – Operation

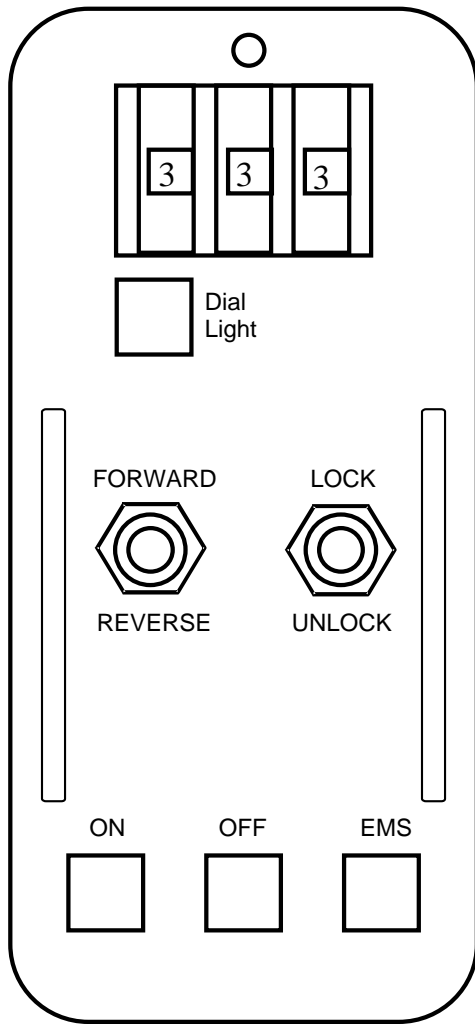

Figure 5-1. Transmitter Diagram

5-1. System Description.

This system is to be used by an operator to select and move a Buffer Trolley into place by moving it forward and reverse and then “locking” it into position. Locking consists of having one and only one unique transmitter capable of moving the Buffer Trolley after it is “locked” into place. A thumb wheel switch on the transmitter does trolley selection. FORWARD, REVERSE, LOCK and UNLOCK are controlled by toggle switches on the transmitter unit. Each transmitter has its own unique ID, so that the Buffer Trolley controller can respond to only the specific unique controlling transmitter. Once “locked” turning OFF the Buffer Trolley controller or even killing power to the trolley controller will not change the controlling transmitter.

5-2. Features.

5-2.1. Transmitter Features.

1. Unique Permit Code.
2. Two thumb wheel switches for the receiver Access Code selection. (Up to 1000 buffer trolleys may be addressed).
3. Standard ON/OFF and EMS (Emergency Stop) push buttons switches.
4. Two bi-directional, momentary, center OFF toggle switches.
 - a. One toggle for movement FORWARD and REVERSE.
 - b. One toggle to LOCKED and UNLOCKED Receiver.
5. Momentary push button to light the thumb wheel switches.
6. Selectable 15 minute time-out-timer.

5-2.2. Receiver Features.

1. Unique Access Code.
2. Master relay that closes when the receiver is turned ON.
3. “Locked indicating LED and relay.
4. “Un-locked indicating LED and relay.
5. Two motion relays, FORWARD and REVERSE.
6. Main power switch that turns the power to the unit ON or OFF.
7. Master Relay disable switch, to allow testing of the unit with the Master relay disabled.
8. Selectable 15 minute time-out-timer.
9. “Memory erase” switch.

5-3. Operation.

The transmitter is turned ON, by pushing the ON push button, the transmitter will:

- Read the thumb wheel switches for the receiver access code.
- Read the transmitter Permit Code from dipswitch SW3 internal to the transmitter. (The transmitter Permit Code is 8 bits, values 1-255). The transmitter Permit Code should be set to be unique for each transmitter).
- Send an ON command with the receiver Access Code and the transmitter Permit Code.

Since each receiver has a unique Access Code and each transmitter has a unique Permit Code.

Section 5 – Operation (Continued)

Any transmitter can dial up and address any receiver (that is turned OFF and UNLOCKED) by dialing that receiver's Access Code number on the transmitter's thumb wheel switch. When a transmitter is turned ON, after a receiver address has been selected, it sends an ON command to the receiver with the transmitter's unique Permit Code. The receiver turns ON and stores this Permit Code in its memory. From this time on, only this initializing transmitter can control this receiver (even if another transmitter is later turned ON with the same receiver address). When the receiver is turned ON a master relay closes in the receiver to drive the main line contactor.

If the operator of the controlling transmitter engages the LOCK function the "locked" condition and the controlling transmitter's Permit Code is stored into the receiver's non-volatile memory. Once a receiver is "locked" only this unique transmitter can control it. Even if the power to the receiver is turned OFF, the "locked" condition and the transmitter's Permit Code will remain stored. This same transmitter will remain the controlling transmitter until the controlling transmitter sends the UNLOCK command and then turns the receiver OFF.

The controlling transmitter also has two direction controls FORWARD and REVERSE, these are always operational by the controlling transmitter in both the LOCKED and UNLOCKED state.

When transmitter 1 is turned ON and the addressed receiver is OFF and has not been locked by another transmitter it will be enabled. If the receiver has been enabled by another transmitter and is presently under the control of that transmitter the receiver will not respond to transmitter 1. If the receiver is OFF, but has been locked by a previous transmitter the receiver will not respond to transmitter 1. The same transmitter can only unlock a receiver that has been locked by that transmitter. The receiver will remain locked even if power is lost to the receiver. A relay output is available to drive a visual display of the receiver's locked or unlock condition. This relay remains closed for the indication of the locked condition even if the transmitter turns OFF the receiver.

5-4. Receiver Locked and Un-locked Indicators.

Two relays and indicators are provided that give an output and indication of the locked or

unlocked condition. The Locked Relay and indicator is K12 and DS12 respectively. The Un-locked Relay and indicator is K11 and DS11 respectively. The Locked Relay will remain ON even if the unit is turned OFF by the transmitter. The Unlocked Relay will open if the receiver is turned OFF by the transmitter.

NOTE

IF DURING THE OPERATION OF THE TRANSMITTER A THUMB-WHEEL SWITCH IS INADVERTENTLY CHANGED THEN TRANSMITTER WILL NO LONGER TRANSMIT COMMANDS. THE TRANSMITTER MUST BE TURNED OFF AND ON AGAIN TO RE-INITIALIZE THE TRANSMITTER. CARE SHOULD TO BE TAKEN WHEN RE-INITIALIZING THE TRANSMITTER THAT THE THUMB-WHEEL SWITCHES ARE SET TO THE RIGHT RECEIVER.

5-5. Time-out-timer functions.

The receiver may be set to time-out in 15 minutes or no time-out by setting Position 7 of dip switch S3 in receiver. Timing out only shuts the receiver down it does not change the state of the receiver as to being "locked or unlocked".

Position 7 of dip switch S3 in receiver –
OFF for 15 minute time-out.
ON for no time-out.

The transmitter may also be set to time-out in 15 minutes or no time-out by setting Position 1 of dip switch S4 in the transmitter. Timing out only shuts the transmitter down it does not change the state of the receiver as to being "locked or unlocked".

Position 1 of dip switch S4 in the transmitter –
OFF for 15 minute time-out.
ON for no time-out.

5-6. EMS Operation.

EMS (Emergency Stop) immediately breaks the main relay and shuts the down. Neither the locked status nor the locked indicating relay is affected by the EMS function. To exit the EMS condition, turn the transmitter OFF and then ON again. *During an EMS condition the Locked Relay will remain closed the if the unit is locked. During an EMS condition the Un-locked Relay will open if the unit is un-locked.*

Section 5 – Operation (Continued)

5-7. In The Event Of Loss Of A Transmitter.

If after locking a receiver the transmitter should fail or be lost the receiver can be unlocked by turning ON Position 1 of dip switch S3 in receiver with the power ON and switching the power to the receiver OFF and ON again. Position 1 of dipswitch S3 in receiver should then be turned OFF or the receiver will not remain locked after a subsequent power downs. Alternately another transmitter can be opened up and its ID code changed to match the failed or lost transmitter.

Transmitter Permit Code's are unique, set at the factory and are recorded by Job number. Contact Telemotive or refer to factory-supplied documentation for Permit Code numbers.

5-8. Transmitter LED Indicator.

When the transmitter is ON the LED flashes slowly. When the unit transmits the LED flashes rapidly. No LED indicator after turning ON at all indicates low batteries, please replace. See Section 5-9. Battery Replacement on this page for battery replacement.

5-9. General Operation.

Make sure that all personnel are clear of the crane equipment movement and no one is under the crane equipment or load.

Turn unit ON by pressing the ON (ON/OFF) button. The red LED should flash rapidly for a few seconds indicating the ON command is being sent to the receiver. After the receiver is turned ON the red LED should flash slowly indicating the transmitter is now ready to send commands.

Perform whatever safety checks are required. See Section 2. Radio Controlled Safety. Operate any horns or alarms as required by local and governmental regulations.

To operate the equipment press and hold the desired function button to maintain operation. Press the directional buttons harder to second position to engage second speed for those crane equipment having two-speed motors.

Always turn system OFF by pressing the OFF (ON/OFF) button on the transmitter when done with operation.

In an emergency always hit E-STOP (EMS) immediately. To clear the emergency condition turn the transmitter OFF and ON again to resume normal operation.

The receiver will time-out after approximately 15 minutes if there is no activity. The transmitter is programmed to time-out if not used for 15 minutes also.



WARNING

BEFORE TURNING ON OR OPERATING THE EQUIPMENT, MAKE SURE ALL PERSONNEL ARE CLEAR OF THE OPERATING AREA AND NO ONE IS STANDING UNDER THE LOAD. FAILURE TO FOLLOW THIS WARNING COULD RESULT IN SERIOUS INJURY OR DEATH AND DAMAGE TO EQUIPMENT.



WARNING

WHEN OPERATING THE EQUIPMENT FOLLOW LOCAL AND GOVERNMENTAL RULES ON THE USE OF HORNS AND ALARMS. FAILURE TO FOLLOW THIS WARNING COULD RESULT IN SERIOUS INJURY OR DEATH AND DAMAGE TO EQUIPMENT.



WARNING

IN AN EMERGENCY, HIT "E-STOP" TO STOP ALL EQUIPMENT MOVEMENT. WHEN EMERGENCY HAS CLEARED TURN THE TRANSMITTER OFF THEN ON AGAIN TO RESUME NORMAL OPERATION. FAILURE TO FOLLOW THIS WARNING COULD RESULT IN SERIOUS INJURY OR DEATH AND DAMAGE TO EQUIPMENT.

Section 5 – Operation (Continued)

5-10. Battery Replacement.

Completely unscrew the four large plastic screws on the four corners of the top of the transmitter. Open the unit and replace the batteries with four fresh alkaline “AA” cells. Be careful to observe polarity. Putting the batteries in backwards can damage the unit.

Section 6 – Wiring

6-1. Wiring Diagram.

The following wiring diagrams are listed for this specific application.

6-2. Installation.

Follow Section 4. Installation Procedure for instructions on how to install the receiver.

6-3. Alarms and Horns.

Make sure that the installation includes the proper alarms and horns and their associated controls as required by local and governmental regulations.

6-4. Connecting Outputs to Drives.

MOV's (transient protectors) are on all the output relays to protect the relays from power surges. MOV's allow a small leakage current that can affect some high impedance circuits. When connecting output relays to drives it may be required to remove the MOV to prevent the leakage current through the MOV from holding in the drive. See Figure 7-1. Receiver Layout for the location of the MOV's. The MOV's are numbered correspondingly to the relays they protect. The MOV's can be cut out of the circuit with a wire cutter. Remember to do this with ALL power off on the crane equipment and all associated controls.

6-5. Legend

The following is the legend for the wiring diagrams below:

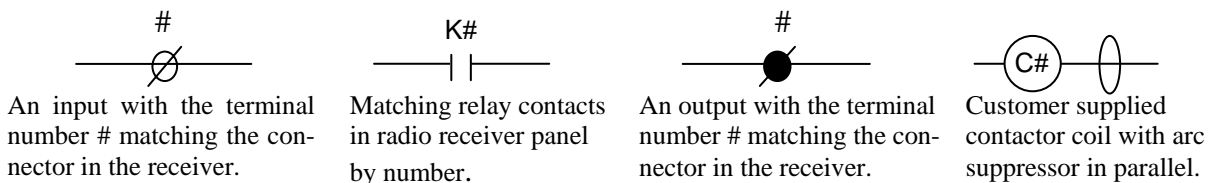
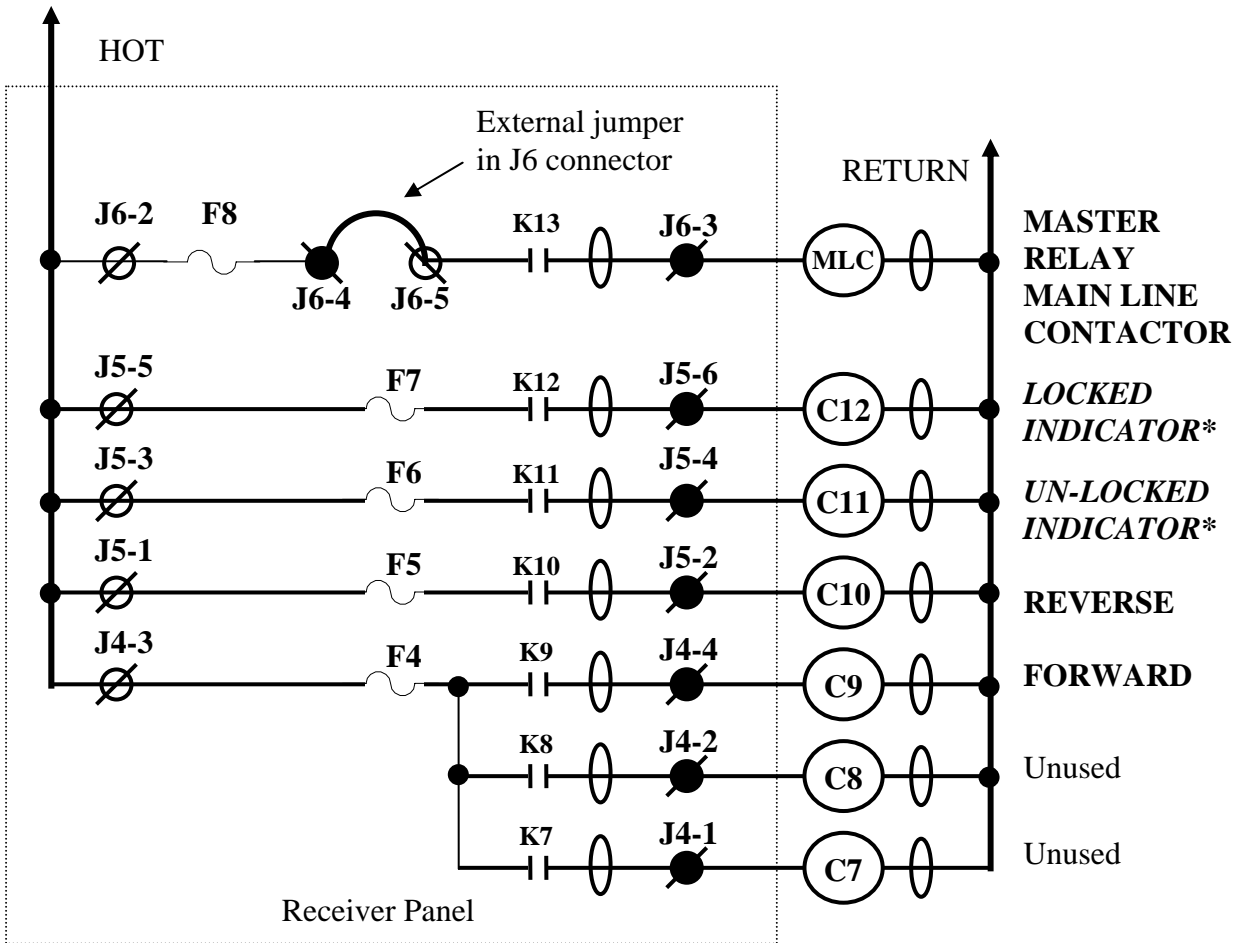

Figure 6-1. Legend.

Section 6 – Wiring (Continued)

Figure 6-1. Wiring Diagram.



**NOTE: K12 remains closed if the unit is locked and the receiver is turned OFF by the transmitter. K11 will open if the unit is un-locked and the unit is turned OFF by the transmitter.*

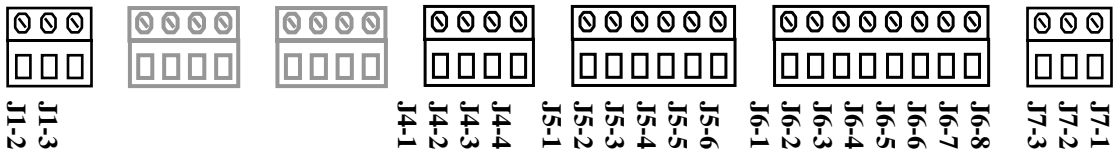

Terminal designators along the right hand side of the receiver.

Section 6 – Wiring (Continued)

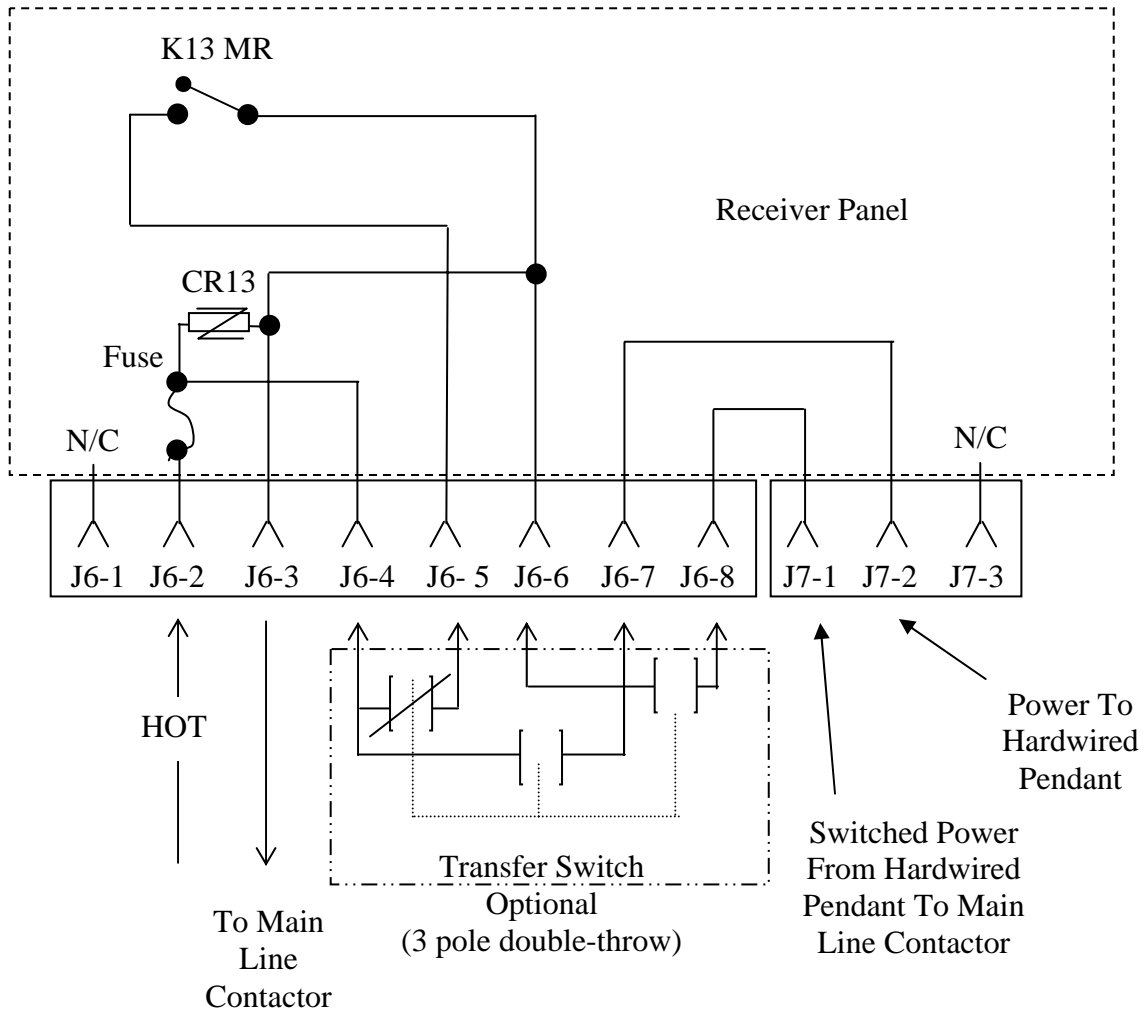

Figure 6-2. Optional Transfer Switch Wiring

6-6. Optional Transfer Switch Wiring Configuration.

If a transfer switch is desired, the additional connectors on the board facilitate the wiring of a transfer switch. The schematic of the transfer switch interface is shown for reference.

Section 7 – Servicing and Programming

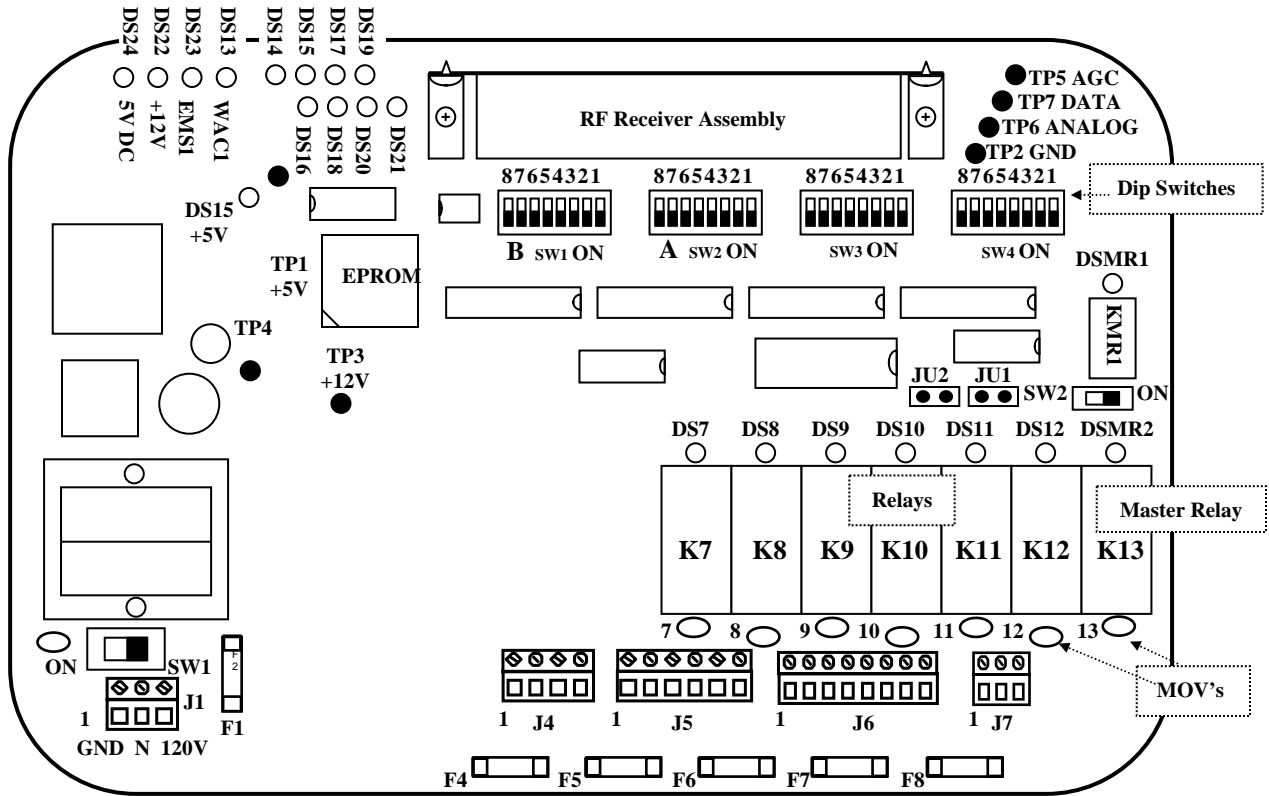

Figure 7-1. Receiver Layout

NOTE

IF THE SYSTEM STOPS WORKING CHECK THE LED INDICATOR ON THE TRANSMITTER. IF IT DOES NOT COME ON WITH PUSHING THE ON BUTTON REPLACE THE TRANSMITTER BATTERIES (FIVE AA CELL BATTERIES).

Table 7-1. Receiver Diagnostic LED Functions. (See Figure 7-1 Receiver Layout for LED locations).

LED	COLOR	FUNCTION
DSMR1	Yellow	<p>Monitors closure of the Security Relay output (KMR1).</p> <p>The LED will be illuminated when the Security Relay has been enabled by an ON command received from the Transmitter Unit. LED will extinguish when an OFF command is transmitted, or an EMS condition is present.</p> <p>The Security Relay controls the 12 VDC power to the MCR relay (K13) and the power to the coils of the control relays (K1 through K12) on the Relay Output Modules.</p>
DSMR2	Red	<p>Monitors closure of the Master Control Relay (MCR) relay (K13).</p> <p>LED will be illuminated when the MCR relay has been enabled by an ON command received from the Transmitter Unit. LED will extinguish, when an OFF command has been transmitted, an EMS condition is present, or SW2 is set to OFF.</p> <p>The MCR controls the 12 VDC power to the Master Relay on the Power Supply Board.</p>

Section 7 – Servicing and Programming (Continued)

DS1-DS12	Red	<p>Monitors closure of the output relays (K1-K12).</p> <p>Normally ON for a function when that specific function is enabled.</p> <p>The LED will be illuminated when a specific relay has been enabled by the respective command received from the Transmitter Unit. The LED will extinguish, when the command is no longer detected.</p>
DS13	Red	<p>Monitors the watchdog timer.</p> <p>Normally OFF.</p> <p>The LED will illuminate momentarily when power is applied to or removed from the system. If the LED is continuously flashing or on, the computer is not working properly. If LED is illuminated constantly (no flashing), the +5 VDC is probably too low. This could be caused by shorts on the board or by a defective voltage regulator. If the LED flashes at a constant rate, the microcomputer chip or EPROM may be defective.</p>
DS14	Yellow	<p>Monitors data synchronization. (Flashes when a properly formatted data signal is received from the transmitter).</p> <p>This LED will flash rapidly when data is transmitted. The LED can be used with DS16 to analyze incoming data. If DS16 is illuminated or flashing when DS14 also is flashing, another Transmitter Unit on the same frequency may be present. This is normal. As more Transmitter Units operated on the same frequency, LED will flash brighter and more often.</p>
DS15	Yellow	<p>Monitors continuity between receiver RF module and CPU module.</p> <p>Normally ON.</p> <p>Off indicates a malfunctioning receiver.</p>
DS16	Red	<p>Monitors received data errors.</p> <p>Normally OFF.</p> <p>A flashing LED during data transmission may indicate interference of the received data. If LED is illuminated continuously when data is transmitted and the system will not respond the Access Code of the Receiver and Transmitter Units may not match. If LED is illuminated when data is not transmitted, another Transmitter Unit may be present on the same frequency with a different Access Code. The presence of activity on this LED does not necessarily indicate a problem. It should be used with other indicators in analyzing system status.</p>
DS17	Yellow	<p>Monitors system activity.</p> <p>Normally FLASHING.</p> <p>If not flashing the microprocessor is dead.</p>
DS18	Red	<p>Monitors the ON command from the Transmitter.</p> <p>LED will flash when an ON command is being received from the Transmitter.</p> <p>While pushing the ON button on the Transmitter this should light.</p>
DS19	Red	<p>Monitors EMS condition.</p> <p>Normally OFF.</p> <p>LED will flash when an EMS command is transmitted and illuminate continuously when the EMS</p>

Section 7 – Servicing and Programming (Continued)

		condition is in effect. An EMS condition may be created when an EMS command is transmitted or when a failure mode is detected by the slave microcomputer. If both DS18 and DS19 are illuminated, a contact monitoring error has been detected. If both DS16 and DS19 are illuminated, the incoming data on the ICC bus has been corrupted.
DS20	Red	Monitors the OFF command from the Transmitter. LED will flash when an OFF command is being received from the Transmitter Unit. While pushing the OFF button on the Transmitter this should light.
DS21	Yellow	Monitors the activity for the Security Relay (KMR1). Normally ON when the receiver is enabled. If the system is ON and the light is not lit there is a serious microprocessor error.
DS22	Green	Monitors the unregulated DC power to the 12 volt regulator Normally ON when AC line is present. If AC Power is present and the AC to DC converter is working then the LED is illuminated. The LED is off if DC power is not present. Check power supply, fuses and if power is applied to the receiver.
DS23	Green	Monitors the regulated 12 VDC power to the Board (receiver board). Normally ON when AC line is present. If 12 VDC power is present then the LED is illuminated. The LED is off if 12 VDC power is not present. Check the 12 VDC regulator and for shorts on the Board.
DS24	Green	Monitors regulated 5 VDC power to the Board. Normally ON when AC line is present. If 5 VDC power is present then the LED is illuminated. The LED is off if 5 VDC power is not present. Check the 5 VDC regulator and for shorts on the Board.

7-1. Receiver Test Points.

Test points are shown as stars on Figure 7-1. Receiver Layout.

TP1 – Monitors regulated 5 VDC

TP2 – Ground for monitoring other test points.

TP3 – Monitors regulated 12VDC.

TP4 – Not used.

TP5 – Monitors AGC (Automatic Gain Control) from RF Receiver module.

TP6 – Monitors analog signal from RF Receiver module.

TP7 – Monitors received data from RF Receiver module.

Section 7 – Servicing and Programming (Continued)

7-2. Typical Wave Forms on an Oscilloscope.

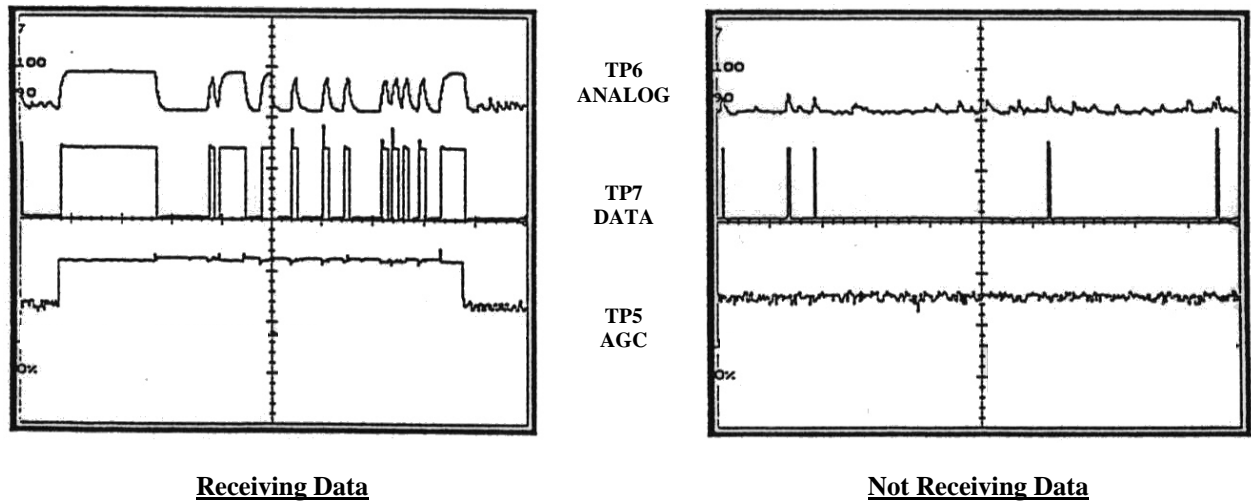

Figure 7-2. Receiver Scope Wave Forms.

Scope Settings:

- Sweep – 1 millisecond per division.
- Sensitivity – TP6 1 volt per division 10X probe.
TP7 2 volts per division 10X probe.
TP5 1 volt per division 10X probe.

Section 7 – Servicing and Programming (Continued)

7-3. Receiver Switch Settings.

SW1 Access Code “B” settings.
See the following section Receiver Access Codes Settings.

SW2 Access Code “A” settings.
See the following section Receiver Access Codes Settings.

SW3
Positions Controls
1 Permit Code erase.
2 Not used, should be OFF.

SW4
Position Controls
1 Time-out-timer disable.
OFF is fifteen-minute timer ON, ON is fifteen-minute timer disabled.
2 Not used, should be OFF.

Figure 7-3. Transmitter Thumb Wheel Switch

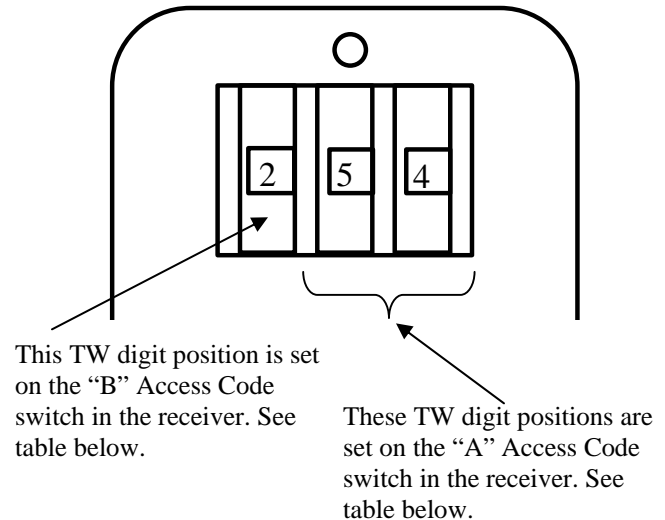

NOTE

DO NOT USE A PENCIL TO TOGGLE THE SWITCHES. THE LOOSE GRAPHITE FROM THE PENCIL CAN DAMAGE THE SWITCH.

7-5. Receiver Access Code Example.

For this example (TW 254) the proper settings for switch “B” (TW 2__) counting from position 8 to 1 is:

0 0 0 0 0 1 0

For this example (TW 254) the proper settings for switch “A” (TW _54) counting from position 8 to 1 is:

0 1 0 1 0 1 0 0

7-4. Receiver Access Code Settings

The transmitter thumb wheel settings must match the Access Code settings in the receiver. For a given thumb wheel setting the Access Code in the receiver the switch settings are to be set using the following tables: (“TW” in the following stands for thumb wheel switch setting).

Select the three-digit number desired for the receiver. Zeros are valid in any position. Example is the number 254. The first digit “2” is set on the “B” Access Code switch in the receiver. See table below for “B” Access Code switch settings. The last two digits are set in the “A” Access Code switch in the receiver. See table below for “A Access Code switch settings. See Figure 7-1. Receiver Layout, for the location of the Access Code switches “A” and “B”.

The tables 7-2 and 7-3 below are for receiver switches “A” (Table 7-3) and “B” (Table 7-2) the number on the top of the columns matches the number of the position of the dip switch. A “0” in the position means the switch in that position should be OFF. A “1” in the position means the switch in that position should be ON. Find the thumb wheel digit in the appropriate row and read the dip switch settings across the row. (“TW” in the following stands for thumb wheel switch setting).

**Table 7-2. ACCESS CODE “B”
DIP SWITCH SETTINGS; 0 = OFF, 1 = ON.**

TW	8	7	6	5	4	3	2	1
0	0	0	0	0	0	0	0	0
1	0	0	0	0	0	0	0	1
2	0	0	0	0	0	0	1	0
3	0	0	0	0	0	0	1	1
4	0	0	0	0	0	1	0	0
5	0	0	0	0	0	1	0	1
6	0	0	0	0	0	1	1	0
7	0	0	0	0	0	1	1	1
8	0	0	0	0	1	0	0	0
9	0	0	0	0	1	0	0	1

Section 7 – Servicing and Programming (Continued)

Table 7-3. ACCESS CODE “A” DIP SWITCH SETTINGS; 0 = OFF, 1 = ON.

TW	8	7	6	5	4	3	2	1
00	0	0	0	0	0	0	0	0
01	0	0	0	0	0	0	0	1
02	0	0	0	0	0	0	1	0
03	0	0	0	0	0	0	1	1
04	0	0	0	0	0	1	0	0
05	0	0	0	0	0	1	0	1
06	0	0	0	0	0	1	1	0
07	0	0	0	0	0	1	1	1
08	0	0	0	0	1	0	0	0
09	0	0	0	0	1	0	0	1
10	0	0	0	1	0	0	0	0
11	0	0	0	1	0	0	0	1
12	0	0	0	1	0	0	1	0
13	0	0	0	1	0	0	1	1
14	0	0	0	1	0	1	0	0
15	0	0	0	1	0	1	0	1
16	0	0	0	1	0	1	1	0
17	0	0	0	1	0	1	1	1
18	0	0	0	1	1	0	0	0
19	0	0	0	1	1	0	0	1
20	0	0	1	0	0	0	0	0
21	0	0	1	0	0	0	0	1
22	0	0	1	0	0	0	1	0
23	0	0	1	0	0	0	1	1
24	0	0	1	0	0	1	0	0
25	0	0	1	0	0	1	0	1
26	0	0	1	0	0	1	1	0
27	0	0	1	0	0	1	1	1
28	0	0	1	0	1	0	0	0
29	0	0	1	0	1	0	0	1
30	0	0	1	1	0	0	0	0
31	0	0	1	1	0	0	0	1
32	0	0	1	1	0	0	1	0
33	0	0	1	1	0	0	1	1
34	0	0	1	1	0	1	0	0
35	0	0	1	1	0	1	0	1
36	0	0	1	1	0	1	1	0
37	0	0	1	1	0	1	1	1
38	0	0	1	1	1	0	0	0
39	0	0	1	1	1	0	0	1
40	0	1	0	0	0	0	0	0
41	0	1	0	0	0	0	0	1
42	0	1	0	0	0	0	1	0
43	0	1	0	0	0	0	1	1
44	0	1	0	0	0	1	0	0
45	0	1	0	0	0	1	0	1
46	0	1	0	0	0	1	1	0
47	0	1	0	0	0	1	1	1
48	0	1	0	0	1	0	0	0
49	0	1	0	0	1	0	0	1

TW	8	7	6	5	4	3	2	1
50	0	1	0	1	0	0	0	0
51	0	1	0	1	0	0	0	1
52	0	1	0	1	0	0	1	0
53	0	1	0	1	0	0	1	1
54	0	1	0	1	0	1	0	0
55	0	1	0	1	0	1	0	1
56	0	1	0	1	0	1	1	0
57	0	1	0	1	0	1	1	1
58	0	1	0	1	1	0	0	0
59	0	1	0	1	1	0	0	1
60	0	1	1	0	0	0	0	0
61	0	1	1	0	0	0	0	1
62	0	1	1	0	0	0	1	0
63	0	1	1	0	0	0	1	1
64	0	1	1	0	0	1	0	0
65	0	1	1	0	0	1	0	1
66	0	1	1	0	0	1	1	0
67	0	1	1	0	0	1	1	1
68	0	1	1	0	1	0	0	0
69	0	1	1	0	1	0	0	1
70	0	1	1	1	0	0	0	0
71	0	1	1	1	0	0	0	1
72	0	1	1	1	0	0	1	0
73	0	1	1	1	0	0	1	1
74	0	1	1	1	0	1	0	0
75	0	1	1	1	0	1	0	1
76	0	1	1	1	0	1	1	0
77	0	1	1	1	0	1	1	1
78	0	1	1	1	1	0	0	0
79	0	1	1	1	1	0	0	1
80	1	0	0	0	0	0	0	0
81	1	0	0	0	0	0	0	1
82	1	0	0	0	0	0	1	0
83	1	0	0	0	0	0	1	1
84	1	0	0	0	0	1	0	0
85	1	0	0	0	0	1	0	1
86	1	0	0	0	0	1	1	0
87	1	0	0	0	0	1	1	1
88	1	0	0	0	1	0	0	0
89	1	0	0	0	1	0	0	1
90	1	0	0	1	0	0	0	0
91	1	0	0	1	0	0	0	1
92	1	0	0	1	0	0	1	0
93	1	0	0	1	0	0	1	1
94	1	0	0	1	0	1	0	0
95	1	0	0	1	0	1	0	1
96	1	0	0	1	0	1	1	0
97	1	0	0	1	0	1	1	1
98	1	0	0	1	1	0	0	0
99	1	0	0	1	1	0	0	1

Section 7 – Servicing and Programming (Continued)

7-6. Transmitter Board.

The Transmitter board is shown in Figure 7-4. Refer to paragraphs below for Servicing Procedures.

NOTE
TO DISABLE TIME-OUT-TIMER
IN TRANSMITTER TURN SW4
POSITION 1 TO ON.

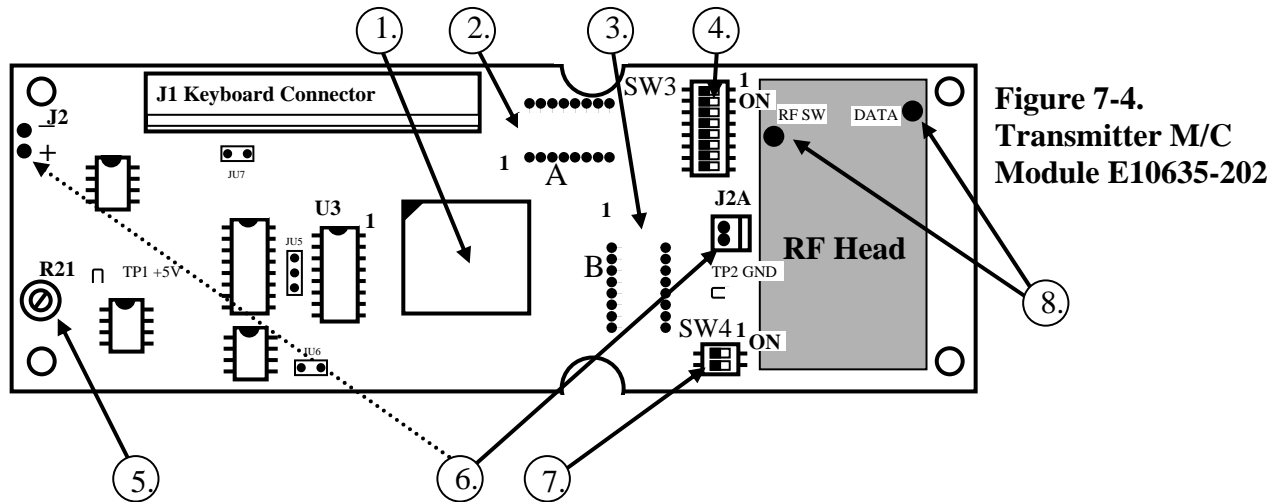

Figure 7-4.
Transmitter M/C
Module E10635-202

- | | | |
|----------------------------------|--|---|
| 1.) EPROM FW2911-0 | 7.) SW3 Permit Code Switch. | 4.) Battery Cable Connections, J2A plug and J2 alternate style. |
| 2.) SW1 "A" Access Code Sockets. | 8.) Battery Monitor Adjustment. Set for 5.8 Volts. | 5.) SW4 Time-out-timer Switch position 1. |
| 3.) SW2 "B" Access Code Sockets. | | 6.) Data check points. |

7-7. Transmitter Switch Settings.

SW3

Positions Controls
1-8 Permit Code. See below for setting information.

SW4

Position Controls
1 Time-out-timer disable. OFF is fifteen-minute timer ON, ON is fifteen-minute timer disabled.
2 Not used, should be OFF.

7-8. Transmitter Permit Code Settings.

No two transmitters should have the same permit code. Permit codes can be arbitrarily set, but a record must be kept of which transmitter has which permit code. All zeros (all switches OFF) is not a valid code.

Do not use a pencil to toggle the switches. The loose graphite from the pencil can damage the switch.

7-9. SW4 Position 1 Time-out-timer Disable. (Normally keep turned "OFF").

The transmitter has an approximate 15-minute time-out-timer. If the transmitter is not used for over 15 minutes it will shut down. This transmitter time-out-timer function is transmitter dipswitch selectable. SW4 position 1 disables the time-out-timer. Turning SW4-1 "ON" disables the time-out-timer.

7-10. To Check Data.

- 1.) For data input use "DATA" connection to RF Head
- 2.) Use "RF SW" for External Trigger input.
- 3.) Use TP2 for Ground.

Section 7 – Servicing and Programming (Continued)

7-11. Battery Monitor Adjustment.

Connect power supply to battery leads observing polarity and set supply voltage to 5.8 volts. Adjust Battery Monitor Potentiometer R21 to just turn off red LED on the front of the transmitter.

NOTE

IF THE BATTERIES ARE INSTALLED BACKWARDS IN THE TRANSMITTER THE UNIT COULD BE DAMAGED

Section 8 – Spare Parts

PART NUMBER	DESCRIPTION
RECEIVER	
FW2911-0	EPROM
E13151-3.2-01	RF RECEIVER MODULE ASSEMBLY
H310-0	RF RECEIVER MODULE ASSEMBLY MOUNTING SCREWS (4)
MP18005-0	RF RECEIVER MODULE MOUNTING BRACKET TOP SIDE (LEFT)
MP18005-1	RF RECEIVER MODULE MOUNTING BRACKET TOP SIDE (RIGHT)
H906-0	RF RECEIVER MODULE MOUNTING BRACKET BOLT (2)
H934-0	RF RECEIVER MODULE MOUNTING BRACKET NUT (2)
E10100-1	MAIN BOARD
H1224-1	MAIN BOARD MOUNTING SCREWS (5)
E10197-0	ANTENNA ASSEMBLY (INTERNAL)
	CONNECTOR PLUG IN:
TS1060-3	3 POSITION (2)
J4655-0	6 POSITION
TS1060-8	8 POSITION
CR260-0	MOV
K1304-0	RELAY (OUTPUT) (7)
S2721-8	DIP SWITCH (ACCESS CODE) (4)
MP10267-0	HOUSING ASSEMBLY, CASE DOORS, SCREWS
E10196-0	FILTER ASSEMBLY
H1223-0	SCREW ROUND HEAD #10-24 X 1"
H1226-0	HEX NUT #10-24
H2079-0	LOCK WASHER #10 SPLIT
TC10K-TR6	INSTRUCTION MANUAL
F2711-2	FUSE ½ AMP, SLO BLO 250V
F2711-0	FUSE 10 AMP SLO BLO 250V
TRANSMITTER	
AA CELL 1.5 VOLTS	BATTERY (5)
S605-0	SWITCH, TOGGLE
S1048-0	SWITCH, MEMBRANE
S1046-15	SWITCH, THUMBWHEEL
E10635-202	MAIN XMTR BOARD

Section 4 – Installation Procedure (Continued)

This page is intentionally blank.

Section 4 – Installation Procedure (Continued)

Figure 4-2. Receiver Enclosure Mounting Holes.

**Ø .25" 4X
(Ø 7mm 4X)**

**7.40"
(188mm)**

**6.46"
(164mm)**

**10.00"
(254mm)**

**Box Size:
10.95" x 7.40" x 5.12"
(278mm x 188mm x 130mm)**

(This page is blank on the other side so it may be removed for use in mounting).

CAUTION: If printing this mounting template locally from a disk or the Internet, recheck template dimensions before drilling. Some printers may distort the dimensions.