

OMNIPULSE DSD

Instruction Manual



MAGNETEK
MATERIAL HANDLING

Part Number: 140-10322-R4
January 2011

© Copyright 2011 Magnetek Material Handling

©2011 MAGNETEK

All rights reserved. This notice applies to all copyrighted material, included with this product, including, but not limited, to this manual and software embodied within the product. This manual is intended for the sole use of the persons to whom it was provided, and any unauthorized distribution of the manual or dispersal of its contents is strictly forbidden. This manual may not be reproduced in whole or in part by any means whatsoever without the expressed written permission of Magnetek

PRODUCT MANUAL SAFETY INFORMATION

Magnetek, Inc. (Magnetek) offers a broad range of radio remote control products, control products and adjustable frequency drives, and industrial braking systems for material handling applications. This manual has been prepared by Magnetek to provide information and recommendations for the installation, use, operation and service of Magnetek's material handling products and systems (Magnetek Products). Anyone who uses, operates, maintains, services, installs or owns Magnetek Products should know, understand and follow the instructions and safety recommendations in this manual for Magnetek Products.

The recommendations in this manual do not take precedence over any of the following requirements relating to cranes, hoists lifting devices or other material handling equipment which use or include Magnetek Products:

- Instructions, manuals, and safety warnings of the manufacturers of the equipment where the radio system is used,
- Plant safety rules and procedures of the employers and the owners of facilities where the Magnetek Products are being used,
- Regulations issued by the Occupational Health and Safety Administration (OSHA),
- Applicable local, state or federal codes, ordinances, standards and requirements, or
- Safety standards and practices for the industries in which Magnetek Products are used.

This manual does not include or address the specific instructions and safety warnings of these manufacturers or any of the other requirements listed above. It is the responsibility of the owners, users and operators of the Magnetek Products to know, understand and follow all of these requirements. It is the responsibility of the employer to make its employees aware of all of the above listed requirements and to make certain that all operators are properly trained. **No one should use Magnetek Products prior to becoming familiar with and being trained in these requirements and the instructions and safety recommendations in this manual.**

WARRANTY INFORMATION

For information on Magnetek's product warranties by product type, please visit www.magnetekmh.com.

TABLE OF CONTENTS

CHAPTER 1: INTRODUCTION.....	4
Assessing the System Requirements	4
Assessing the Drive Environment.....	4
OmniPulse DSD General Specifications.....	5
AC Reactor Specifications	6
CHAPTER 2: INSTALLATION.....	7
Precautionary Statements.....	7
OmniPulse DSD System Components and External Devices	9
Pre-Installation Considerations	10
Installing the Drive	11
CHAPTER 3: WIRING	18
Suggested Circuit Protection Specifications and Wire Size	20
Power Circuit Wiring Procedures	21
Control Circuit Terminals	23
Electrical Hook up	26
Pre-power Check	28
CHAPTER 4: PROGRAMMING FEATURES	30
Drive Description.....	30
Software Operating Features.....	36
Power Conversion Unit (PCU).....	37
Interface Specifications.....	40
Standard Control/Display Unit Operation.....	40
Operating Mode Descriptions	56
Parameter Function Descriptions.....	63
Modbus RTU Communications	85
CHAPTER 5: TROUBLESHOOTING	93

CHAPTER 1: INTRODUCTION

Assessing the System Requirements

It is important to know how you're going to use the drive before you start installation and wiring. You will need to know your requirements for the following components:

- Speed control method(s)
- Braking method(s)
- Power source voltage, number of phases, and kVA rating
- Power source location
- Wire size
- Grounding location and method

Assessing the Drive Environment

When you choose a location for OmniPulse DSD, perform the following steps:

1. Ensure that three-phase power source is within (+10% to -10%) of nominal input voltage range of 150 to 525VAC. The drive is not sensitive to phase sequence. Input power specification is contained on drive nameplate.
2. Ensure that control power is 115VAC (-10% to +10%), 1 phase.
3. Ensure the encoder is supplied with +5VDC.
4. If the amperage requirement is greater than 200 mA, provide an auxiliary power supply to the encoder.
5. When connecting a drive (230V/460V, Transformer or Reactor 100AMP and smaller) a 3% line reactor is required. Above 100AMPS a full rated Isolation Transformer is required. Transformer kVA is to be equal to (output VDC multiplied by output current) divided by 884. $kVA = VDC * ADC / 884$
6. Ensure that the encoder wiring is less than 300 feet.
7. Ensure that the encoder wiring is isolated from the power wiring.
8. Ensure that the encoder wiring shield is grounded only at drive end.
9. Ensure that the drive circuit wiring is protected or isolated from:
 - Ambient temperatures outside the range of +32° F to +113° F (-0° C to +45° C). (Consult Magnetek if you must exceed this temperature range.)
 - Rain or moisture
 - Corrosive gases or liquids
 - Direct sunlight
 - Severe mechanical vibration
10. Ensure that the drive is housed in an appropriate NEMA-rated enclosure.
11. For severe-duty applications (for example—long lifts) or with 75-Hp-or-greater motors, ensure that the drive control system is adequately cooled, even though the ambient temperature limit is not exceeded. For more information, contact Magnetek.

OmniPulse DSD General Specifications

230V Class

Specification	Specification Values and Information for Each 230V-Class Model (C.F.= Consult Factory)									
	144-45195	144-45200	144-45205	144-45210	144-45215	144-45220	C.F.	C.F.	C.F.	C.F.
Rated current (A)	10	31	62	106	206	330	480	640	1100	1550
Capacity (kVA)	2.7	6.8	14	27	53	81	120	158	236	345

460V-Class

Specification	Specification Values and Information for Each 460V-Class Model (C.F.= Consult Factory)									
	144-45195	144-45200	144-45205	144-45210	144-45215	144-45220	C.F.	C.F.	C.F.	C.F.
Rated current (A)	10	31	62	106	206	330	480	640	1100	1550
Capacity (kVA)	5.7	14	28	57	110	120	249	328	492	718

230V and 460V-Classes

Specification	Specification Value and Information for All Models
Certification	UL, CUL
Rated input power supply volts & freq	Line
	Control
Allowable input voltage fluctuation	+10% or -10% of nominal
Allowable input frequency fluctuation	48 to 62 Hz
Control method	Full wave six pulse SCR control
Maximum output voltage VDC	Max output voltage 240VDC for 230VAC 3 phase input. 500VDC for 460VAC 3 phase.
Field weakening range	Up to maximum nameplate RPM
Output speed control range	1000:1
Regulation	0.05% of set speed with digital encoder speed feed back
Overload capacity	150% of rated load for 1 min. 200% full load current for 10 seconds
Remote frequency reference sources	0-10VDC, ±10VDC
Accel/decel times	0.5 to 15.0 sec both ramp parameters are independently adjustable
Motor overload protection	I ² to motor overload protection
Overcurrent protection level (OC1)	200% of rated current for 10 seconds
Circuit protection	Instantaneous over-current protection, blown-fuse protection, shorted SCR (test upon power-up)
Undervoltage protection level	The AC input power has dropped below 80% of the Nominal AC Line Voltage (F#10) for 3 consecutive cycles or lower than 50% for one cycle.

Specification	Specification Value and Information for All Models
Heatsink overtemperature	Thermostat trips at 125° C
Current Limit	Maximum Armature Current Limit of 0-300%
Other protection features	Motor contractor, motor overload, overspeed, mechanical brake failure, open armature, E-stop circuit fault, failure touchless, mechanical overload and field loss.
Location	Indoors; requires protection from moisture, corrosive gases, and liquids
Ambient operating temperature	32° to 113°F (0° to 45°C) for open chassis
Storage temperature	32° to 113°F (0° 45°C)
Humidity	95% relative; noncondensing
Vibration	1 G less than 20 Hz; 0.2 G for 20-50Hz
Elevation	3300 Ft. (1000M) or less

AC Reactor Specifications

Reactors, input (line) devices, protect direct current drives and other load devices against excessive voltage and current.

The following guidelines may help determine input reactor requirements:

- 100A and below a 3% line reactor is required
- Above 100A an isolation transformer is required $KVA=(VDC \times ADC)/884$

230V and 460V - Class

Model Number	230V and 460V Part Number	Maximum Amps of Reactor
45195	REA460-7.5	12
45200	REA460-15	25
45205	REA460-30	45
45210	REA460-75	100

CHAPTER 2: INSTALLATION

Precautionary Statements

IMPORTANT, *WARNING*, *CAUTION*, and *Note* statements are used throughout this manual to emphasize important and critical information. These statements help ensure safety and prevent product damage. The statements are defined below:



IMPORTANT

A statement of conditions that should be observed during drive setup or operation to ensure dependable service.



CAUTION

A statement of conditions that must be observed to prevent undesired equipment faults or degraded drive system performance



WARNING

A statement of conditions that **MUST BE OBSERVED** to prevent personal injury, death, or serious equipment damage.

NOTE: A *NOTE* statement is used to notify installation, operation, programming, or maintenance information that is important, but not hazard-related.



WARNING

- When preparing to mount the OmniPulse DSD drive, lift it by its base. Never lift it by the front cover.
- Mount the drive on nonflammable material.
- The OmniPulse DSD drive generates heat. For the most effective cooling possible, mount it vertically. For more details, refer to the “OmniPulse DSD Dimensions/Heat Loss-Open Chassis” in this chapter.
- When mounting units in an enclosure, install a fan or other cooling device to keep the enclosure temperature below 113°F (45°C).

NOTE: Failure to observe these Warnings may result in equipment damage.

This chapter explains the following:

1. Choosing a location
2. OmniPulse DSD components and external devices
3. Drive environment
4. Drive installation

In addition, this section will cover information on the components that interconnect with OmniPulse DSD.

Choosing a Location

Be sure that the drive is mounted in a location protected against the following conditions:

- Extreme cold and heat. Use only within the ambient temperature range:
Open Chassis: +32 to 113°F (0 to 45°C)
- Direct sunlight (not for use outdoors)
- Rain, moisture
- High humidity
- Oil sprays, splashes
- Salt spray
- Dust or metallic particles in the air
- Corrosive gases (e.g. sulfurized gas or liquids)
- Radioactive substances
- Combustibles (e.g. thinner, solvents, etc.)
- Physical shock, vibration
- Magnetic noise (e.g. welding machines, power devices, etc.)

OmniPulse DSD System Components and External Devices

OmniPulse DSD Drive Components

- Logic input relays
- Logic output relays
- Motor contactor
- 3 Phase input AC line reactor or 3 Phase input isolation transformer

Required External Devices

- Motor
- User input device (pendant, joystick, PC, PLC, radio, or infrared control)
- External circuit protection devices (fuses or circuit breakers).
- R-C surge suppressors on contactor coils

Pre-Installation Considerations

Receipt of Shipment

All equipment is tested against defect at the factory. Any damages or shortages evident when the equipment is received must be reported immediately to the commercial carrier who transported the equipment. Assistance, if required, is available from your Magnetek representative. Always refer to the order number, equipment description, and serial number when contacting Magnetek.

Unpacking Instructions

Remove the protective shipping material from around the equipment. Remove all packing material. Unbolt the equipment from its crate. Inspect for loose wiring. Make sure that all contact wedges and other shipping devices have been removed.

Packing Instructions for Reshipment or Storage

For long periods of storage, equipment should be covered to prevent corrosion and should be placed in a clean, dry, location. If possible, equipment should be stored in its original crating. Periodic inspection should be made to ensure that the equipment is dry and that no condensation has accumulated. The equipment warranty does not cover damage due to improper storage.

The drive should be packed in its original shipping container if it is required that it be shipped. Assistance, if required, is available from your Magnetek representative.

Physical Installation

The OmniPulse DSD Drive is air-cooled. The lowest HP rated units are cooled by convection; all other units are equipped with a fan to ensure adequate airflow. Select a site for installing the drive that is clean and well ventilated. Maintenance will be minimized if the drive is located in a clean atmosphere.

The standard drive is designed for vertical mounting. Attach the drive to a cabinet panel or other vertical structure using the mounting holes provided at the back of the drive. Ensure that the unit is level.

Installing the Drive

To install OmniPulse DSD:

1. Ensure the drive will be used in a proper environment.
2. Review “OmniPulse DSD Terminal Diagram”.
3. Determine the sizes and connection locations for the drive components and external devices that need to be wired. Locate the ground.
4. Determine the position of the subpanel.
5. Ensure that the drive is positioned vertically so that the heat can dissipate properly.
6. Ensure that the air can flow freely around the heatsink as shown in outline drive chassis drawings.

Note:

- *The recommended clearances at the top, bottom, and both sides of the OmniPulse DSD Drive are the same for both open chassis and NEMA 1 enclosures.*
 - *Allowable intake air temperature: 32°F to 104°F (-0°C to +40°C)*
 - *If necessary, a heater or air conditioner must be used to maintain the temperature range listed above.*
7. Lay out the wire runs. Size the wire according to NEC Table 610-14(a). At a minimum, use #16 AWG for control wiring and #12 AWG for power wiring. When performing this step:
 - Ensure that the drive control circuit and power circuit wires are perpendicular to each other at any point they cross.
 - Keep power and control festoon wiring in separate cables.
 - Separate control drive circuit and power circuit wiring on the terminal block strip.
 8. Obtain the appropriate hardware for mounting.
 9. Mount the subpanel or surface to which you are mounting the drive (contact Magnetek if you need advice on mounting, especially for larger drives).
 10. Fasten the drive and components to the subpanel.
 11. Remove the terminal cover.
 12. Follow the wiring practices outlined in Chapter 3, “Wiring”.

OUTLINE DRAWING 106A

TOP VIEW OF OPTIONAL COVER

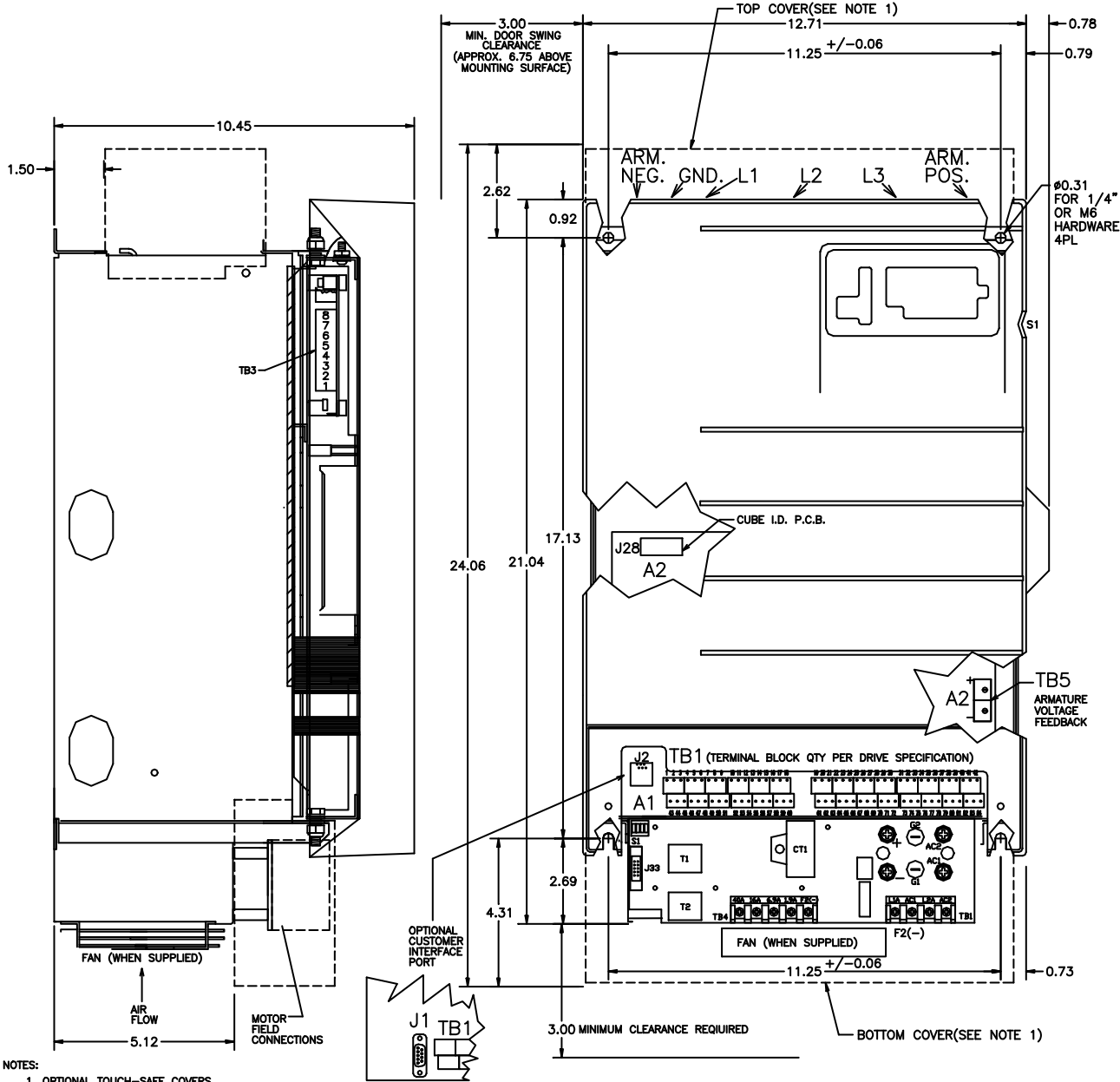
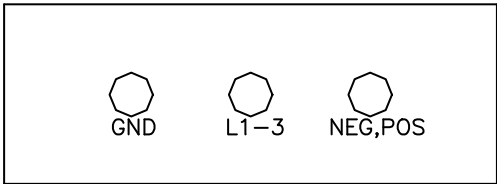

NOTES:
1. OPTIONAL TOUCH-SAFE COVERS.

Figure 1: Drive Chassis Outline, OmniPulse DSD 100 Amp

OUTLINE DRAWING 206A

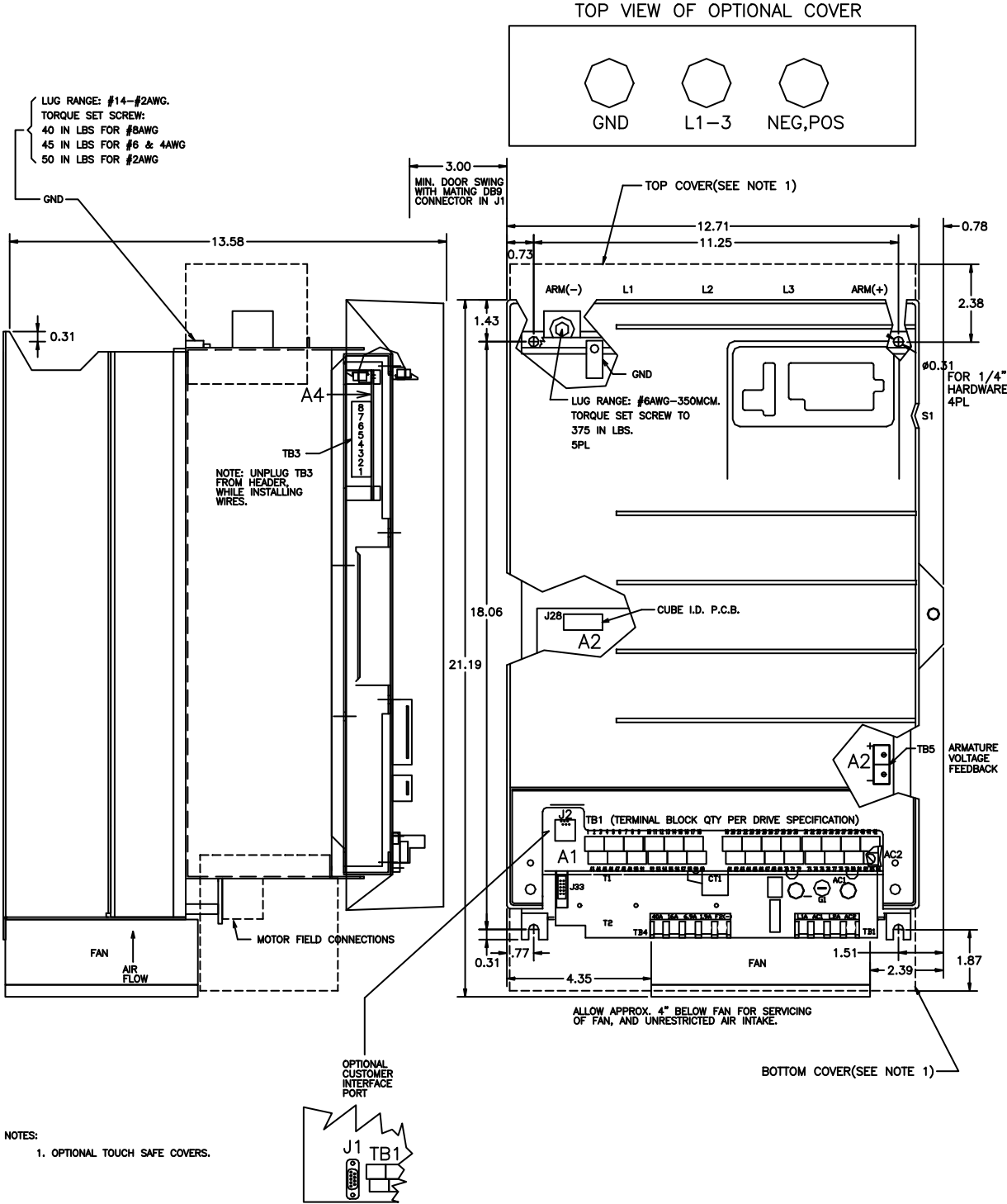

Figure 2: Drive Chassis Outline, OmniPulse DSD 195 Amp

OUTLINE DRAWING 330A

	GND	ARM(-)	L1-3	ARM(+)
COND. RANGE	1/0-14	750-1/0	600-4	800-300
TORQUE (in-lbs)	**	50	50	375

**** TORQUE/GAUGE:**
 14-10AWG 25 in-lbs
 8AWG 30 in-lbs
 6-4AWG 35 in-lbs
 3AWG-1/0 40 in-lbs

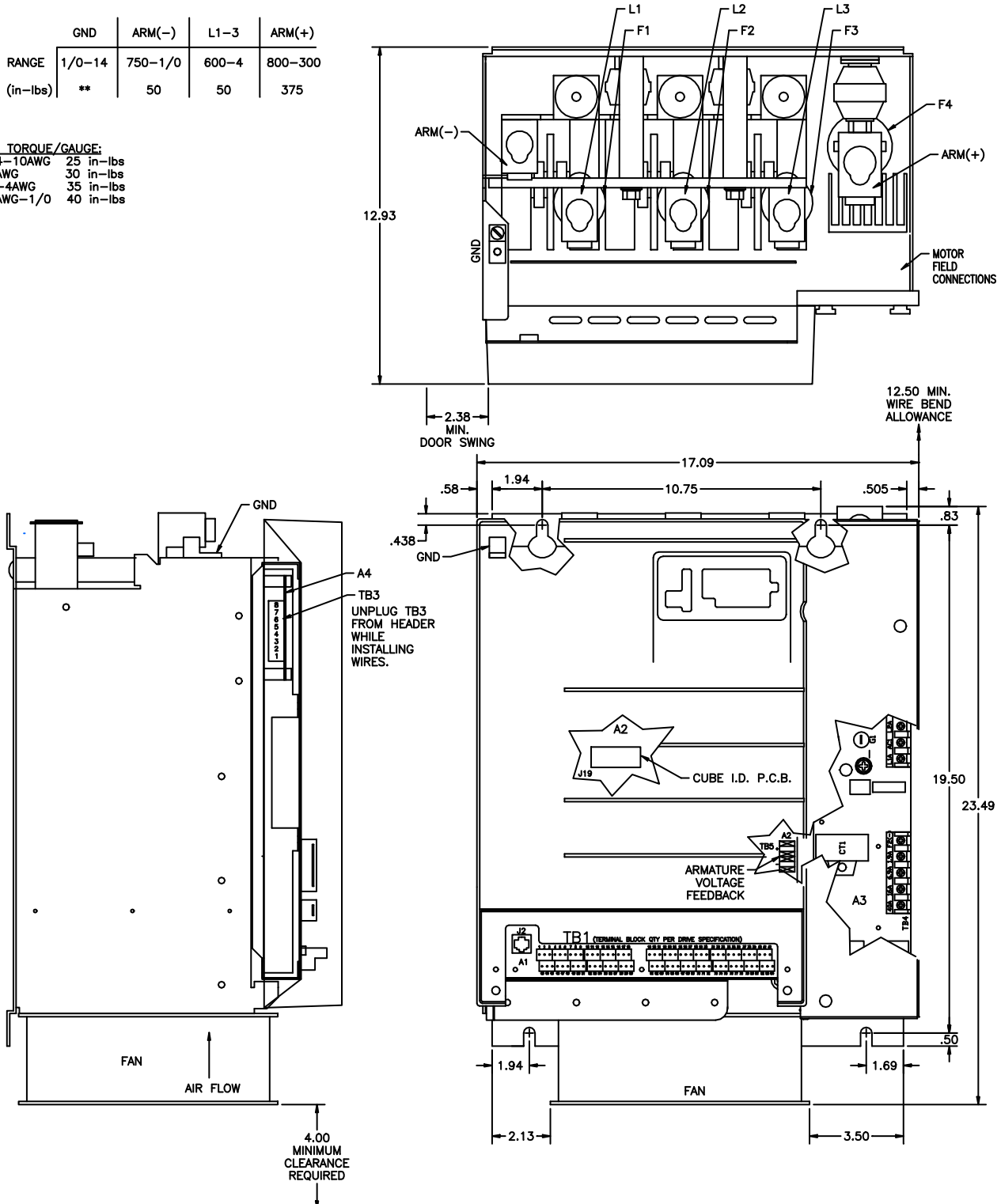

Figure 3: Drive Chassis Outline, OmniPulse DSD 300 Amp

OmniPulse DSD DC Drive Dimension / Heat Loss

Part Number	Drive Capacity (Amps)	Height	Width	Depth	Weight	Heat Loss (Watts) Total
144-45195	10	21 in (540mm)	13 in (330mm)	10" (260mm)	29lbs (13KG)	400
144-45200	31	21 in (540mm)	13 in (330mm)	10" (260mm)	29lbs (13KG)	400
144-45205	62	22 in (560mm)	13 in (330mm)	10" (260mm)	42lbs (19KG)	400
144-45210	106	22 in (560mm)	13 in (330mm)	10" (260mm)	42lbs (19KG)	400
144-45215	206	22 in (560mm)	13 in (330mm)	14" (360mm)	62lbs (28KG)	645
144-45220	330	24" (610mm)	17" (430mm)	13" (330mm)	110lbs (50KG)	345
Consult Factory	480	44" (1120mm)	32" (810mm)	16" (410mm)	225lbs (102KG)	1497
Consult Factory	1550	71" (1800mm)	45" (1140mm)	18" (460mm)	660lbs (300KG)	Consult Factory

Selecting, Mounting and Wiring of the Digital Encoder

Encoder Selection

A quality encoder is recommended for use with the OMNIPULSE DSD controller for speed feedback. The encoder should be a two-channel, quadrature, zero-speed type device with differential line drivers. The OMNIPULSE DSD drive supplies +5V power for an encoder; however, the encoder and feedback signals may operate from another source (up to 15 volts if desired). The Pulses per Revolution count must be sufficient to provide an adequate frequency feedback at very low speeds, and yet not exceed 300 kHz (per channel) at top speed. For most applications this target will be met when the feedback frequency (per channel) is greater than 50KHz at contract speed. For geared machines with motors running at 1750 or 1150RPM, a 2500PPR encoder may be used. Direct mounted hollow shaft encoders, electrically insulated from the motor shaft and motor frame, will yield the best results. The use of an analog AC or DC tachometer is not supported by OMNIPULSE DSD drives software or hardware.

Mounting

Proper mounting and alignment of the digital encoder used for speed feedback is very critical for the smooth operation of the OMNIPULSE DSD controller. Even the slightest wobble of the encoder shaft due to misalignment can cause once-per-revolution torque pulsation that have the potential of exciting natural rope resonance frequencies.

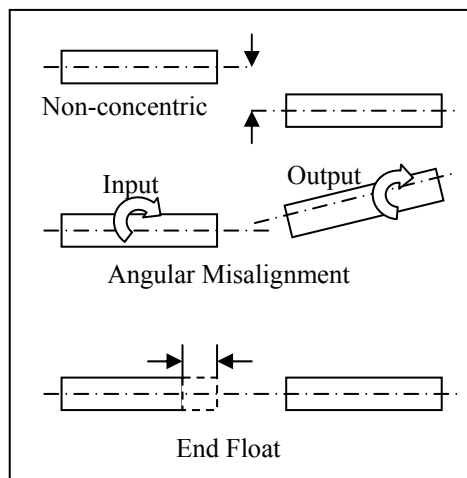

Figure 4: Common Problems in Encoder Mounting

Magnetek recommends mounting the encoder used for motor speed feedback directly to the motor shaft, usually to the end opposite the drive end. Normally a stub shaft is mounted in the end of the motor shaft. The stub shaft must be absolutely concentric (share the same center) with the motor shaft, and have no angular misalignment. The encoder is normally face mounted to a bracket that is mounted on the motor. A standard NEMA 56 "C" face adapter bracket may be used, or a special fabricated bracket may be designed and used. The encoder should be mounted on the bracket and positioned so that the encoder shaft and the stub shaft are concentric and have no angular misalignment or run-out. The coupling should have electrical insulation to isolate the motor shaft from that of the encoder. The body of the encoder should be electrically insulated from the motor frame.

Coupling

There is likely to be some small amount of misalignment, regardless of the care used in mounting the encoder. A good quality coupling between the encoder shaft and the motor stub shaft can help avoid the remaining problems due to shaft runout. A good coupling will also offer some protection for the encoder against end float, a condition which exists in gearing on direction changes, and which can be transmitted through the motor. Again, the coupling should provide electrical insulation between the motor and encoder shafts.

Exceeding Operating Specification

Do not exceed the operating specification of the encoder/drive, in order to prevent the encoder from providing incorrect data. All encoders have inherent mechanical and electronic limitations regarding speed. The combination of several design factors including bearings, frequency response of the electronics, and PPR of the encoder, etc. combine to determine "maximum operating speed". Exceeding the maximum speed may result in incorrect data or premature failure. The encoder manufacturer can provide both the electrical and mechanical encoder specifications.

To determine the encoder's maximum operating speed:

Step 1:

Determine maximum electronic operating speed in RPM.

$$RPM = \frac{\text{Encoder freq. response (kHz)} \times 60}{\text{Encoder PPR}}$$

Step 2:

- A. If the RPM calculated in Step 1 is less than or equal to the encoder's maximum mechanical RPM specification, then the RPM calculated in Step 1 is the maximum operating speed specification for this particular encoder application.
- B. If the RPM calculated in Step 1 is greater than the encoder's maximum mechanical RPM specification, then the maximum mechanical RPM specification is the maximum operating speed for this encoder application.

Step 3:

Compare the maximum operating speed as determined in Step 2 above with the application requirements.

To determine if the application exceeds the operating specification of the OmniPulse DSD:

- Calculate the maximum pulses per revolution (PPR) for this application (using the HPV 900 frequency limit of 300 kHz and 120% of the application's top speed)

$$PPR_{\max} = \frac{300,000 \text{ Hz} \times 60}{\text{max application RPM} \times 1.2}$$

Verify that the selected encoder's PPR is below the calculated maximum PPR (PPR_{max}) for this application.

CHAPTER 3: WIRING



WARNING

Before you wire the drive, review the following practices to help ensure that your system is wired properly.

- Use hard contact inputs rather than solid-state inputs on external user input devices.
- OmniPulse DSD drives require input reactance. Ensure that there is at least 3 percent impedance between the power source and the drive input. To accomplish this, you can install an isolation transformer, or use an AC line reactor on the input of drives with 60HP or less output. If enough impedance isn't provided, excessive peak currents could damage the input power supply circuit.
- Comply with "Suggested Circuit Protection Specifications".
- Use time delay fuses, which are sized at 150% of drive's continuous-rated current, for drive input protection.
- Use appropriate R-C or MOV type surge absorbers across the coil of all contactors and relays in the system. Failure to do so could result in noise-related, nuisance fault incidents.
- Do not ground the drive with any large-current machines.
- Before you use any welding or high-current machines near the crane, disconnect all line and ground wiring.
- A two or three pole output contactor, with auxiliary contacts, should be installed between the drive and motor.
- Do not let the wiring leads come in contact with the drive enclosure.
- Do not connect power factor correction capacitors to the drive input or output.
- Hard-wire the drive and motor (e.g., festoon cable). Do not use sliding collector bars.
- If you have a user input device, use shielded cable between the drive input terminals and the interface output terminals or user input device(s).
- Before turning on the drive, check the output circuit for possible short circuits and ground faults.
- Increase the wire size by one size for every 250 ft. between the drive and motor; suggested for center driven cranes, trolleys and bridges.
- When using more than one transformer for the drive's power, properly phase each transformer.
- To reverse the direction of rotation, interchange any two armature motor leads (A1 and A2). (Changing L1, L2 or L3 will not affect the shaft rotation direction.)
- Use shielded cable for all low-level DC speed reference signals (0 to 10VDC, 4 to 20 mA). Ground the shield only at the drive side.
- Please observe National Electrical Code (NEC) guidelines when wiring electrical devices.

Note: Failure to observe these warnings may result in equipment damage.

TYPICAL POWER WIRING

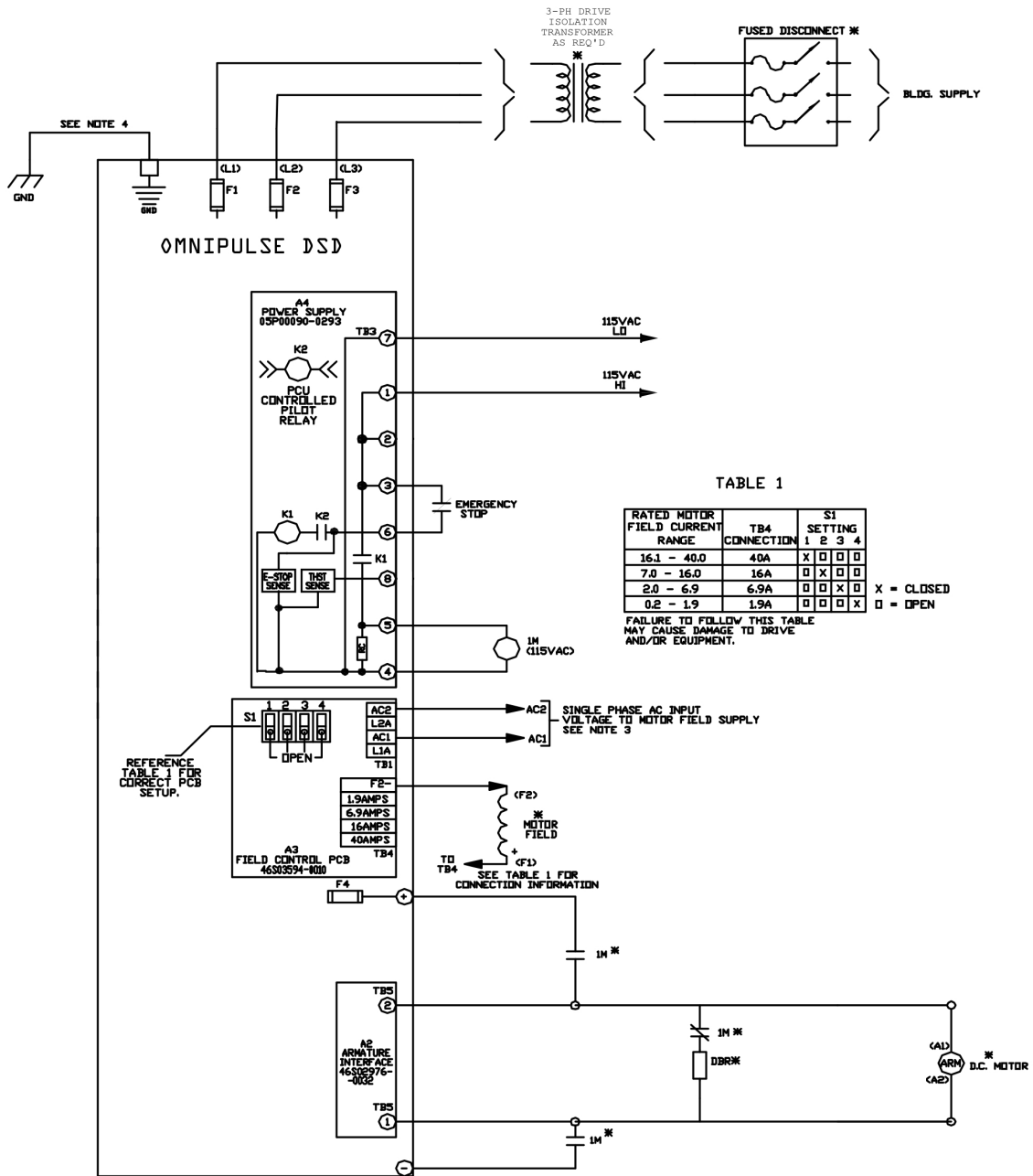

Figure 6: TYPICAL POWER WIRING

Suggested Circuit Protection Specifications and Wire Size

In order to comply with most safety standards, some circuit protective devices should be used between the incoming three-phase power supply and the OmniPulse DSD. These devices can be thermal, magnetic, or molded-case breakers (MCCB); or “slow-blow” type fuses such as “CCMR” or “J.”



CAUTION

The following guidelines are only suggested values. Always conform to local electrical codes and wiring practices.

Wiring Size

Model #	Rated Current(A) Input Fuse	Time Delay Input Fuse Class	Inverse Time Molded/Case Circuit Breaker	Power Circuit Wiring (1) (AWG)	Control Wiring (AWG)	Ground Copper (2) (AWG)
230/460V Class						
144-45195	15	CC	20	12	16/14	12
144-45200	45	J	60	10	16/14	10
144-45205	70	J	110	4	16/14	8
144-45210	150	J	200	1/0	16/14	6

References:

1. NFPA 70 National Electrical Code 2008 Table 610-14(a) 90° C, 60-minute, copper, 45° C ambient.
2. NFPA 70 National Electrical Code 2008. Table 250-122.

Power Circuit Wiring Procedures

To wire the power circuit for OmniPulse DSD:

1. Run the three-phase power supply wires through an appropriate enclosure hole.
2. Referring to “Suggested Circuit Protection Specifications—OmniPulse” and the following two tables, connect the three-phase power supply wires to a circuit protection system.
3. Connect the three-phase power supply wires from the circuit protection Terminals L1, L2 and L3.
4. From Terminals A1 and A2, connect the power output wires to the armature leads A1 and A2.
5. From drive terminals F1 and F2 (proper current selection point) connect motor field.

230/460 Power V Class Terminal Functions

	<i>Model</i>	42195 – 45210	45215	45220	Consult Factory	Consult Factory
	<i>Rated Current</i>	10 to 106 Amps	206 Amps	330 Amps	480 Amps	640 to 1550 Amps
Terminal	L1	Main circuit input power supply				
	L2					
	L3					
	ARM (+)	ARM(+)			P	P
	ARM (-)	ARM(-)			N	N
	F1(+)	F1 (+) (Proper Amp Range)			TB2(1)	TB1(3)
	F2(-)	F2(-)			TB2(2)	TB2(4)
	Armature Voltage (+) Feedback	TB5(+)			TB1(3)	P
	Armature Voltage (-) Feedback	TB5(-)			TB1(4)	N
	↓	Ground terminal (Ground resistance: 100 Ω or less)				

Control Circuit Terminals

The table below outlines the functions of the control circuit terminals.

Classification	TB1 - Terminal	Signal Function	Description	Signal Level
Sequence Input Signal	7	M Contactor Auxiliary	M Contactor Energized when closed	24VDC \pm 10%
	49	Forward run/stop	Forward run when closed, stop when open	
	8	Reverse run/stop	Reverse run when closed, stop when open	
	9	Speed 2 (default)	Multi-Function contact input Parameter 71	
	10	Speed 3 (default)	Multi-Function contact input Parameter 72	
	11	Speed 4 (default)	Multi-Function contact input Parameter 73	
	12	Speed 5 (default)	Multi-Function contact input Parameter 74	
	50	Speed 6 (default)	Multi-Function contact input Parameter 75	
	51	Fault Reset N/O(default)	Multi-Function contact input Parameter 76	
	52	Not used	Multi-Function contact input Parameter 77	
Sequence Input Signal	53	Not used	Multi-Function contact input Parameter 78	
	54	Micro Speed Gain 1 (default)	Multi-Function contact input Parameter 79	
	48	Control +24 supply	+24VDC for logic input	

Classification	TB1 - Terminal	Signal Function	Description	Signal Level	
Analog Input Signal	28	+10V Power supply output	For analog command +10VDC power supply	+15V (Allowable current 20 mA max.)	
	29	-10V Power supply output	For analog command -10VDC power supply	-15V (Allowable current 20 mA max.)	
	68-63	Analog speed reference	-10 to +10V/-100% to 100% 0 to +10V/0 to 100%	-10 to +10V (20k Ohm), 0 to +10V/(20k Ohm)	
	76-71	Analog torque reference	-10 to +10V/-100% to 100% 0 to 10V/0 to 100%	-10 to +10V (20k Ohm), 0 to +10V/(20k Ohm)	
Analog Input Signal	57	Common terminal for control circuit	0V	-	
	27, 47, 77	Connection to shield sheath of signal lead	-	-	
Relay Output Signal	42	Drive Fault N.O.contact (K1)	Drive Fault	Dry contact Contact capacity: 115VAC, 500 mA or less 30VDC, 2A or less	
	41	Center of N.O./N.C. (K1)			
	40	N.C. Contact (K1)			
	38	N.O. (K2) Contact	Multi-function output (K2) Parameter #82 Default (Brake Release)		
	39	Brake release			
	36	N.O. (K3) Contact	Multi-function output (K3) Parameter #83 Default (Brake Release)		
	37				Brake release
	81	(K4) Open collector UP or DOWN limit	Multi-Function output (K4) Parameter #84 Default (UP or DOWN limit)		Open collector Rated 500mA @ 24VDC
	79	(K5) Open collector Alarm-1	Multi-Function output (K5) Parameter #85 Default (Alarm-1)		
	82	Control +24V Supply	+24VDC for logic output		
	83	(K6) Open collector Drive running	Multi-Function output (K6) Parameter #86 Default (Drive running)		Open collector Rated 500mA @ 24VDC
	84	(K7) Open collector Brake hold fault	Multi-Function output (K7) Parameter #87 Default (Brake hold fault)		

Classification	TB1 - Terminal	Signal Function	Description		Signal Level
Analog Output Signal	45	Multi-Function Analog Output 1	0 to $\pm 10V$	Multi-Function analog Parameter 60-62	0 to $\pm 10V$ Max. $\pm 5\%$ 2mA or less
	80	Common			
	46	Multi-Function Analog Output 2	0 to $\pm 10V$	Multi-Function analog monitor 2 Parameter 65-67	0 to $\pm 10V$ Max. $\pm 5\%$ 2mA or less
Encoder	2	A	Encoder Feedback	Parameter Function# 15	0 to 300 kHz $\pm 5\%$ High level voltages 3.5 to 5 Low level voltages 0.0 to 0.8 Duty cycle (on/off) 30% to 70%
	3	A-			
	4	B			
	5	B-			
	1	+5VDC	Encoder power supply		+5VDC $\pm 5\%$ 350 mA
Ground	43	Common			
	44	Common			
	1	Ground	Jumper 44 to 1 R- and S-		
		Modbus Signal Common			

Electrical Hook up

Ensure that wire size and disconnect devices conform to the installation contractor's drawings and to all applicable codes.

Power Connections

The three phase input power to the drive is fuse protected internal to the Drive. However, it is recommended to provide branch circuit protection by means of a circuit breaker in accordance with the National Electrical Code, (USA) or as may be required by other local electrical codes.

Signal Connections

All low power, low voltage wiring to the OmniPulse DSD controller should be run separate from the 115VAC or higher power connections and the DC motor armature and field connections. These include:

- Encoder Wiring
- Speed Reference Wiring
- Pre-Torque Reference Wiring
- 24 VDC Logic Inputs
- Analog Outputs
- Open Collector Logic Outputs

Rewiring these signals in shielded wire is recommended to avoid noise pickup.

Grounding

The OmniPulse DSD controller, the utility power system feeding it and all other connected power equipment should be grounded as follows:

The facility power ground and grounding wire sizes should comply with NEC, UL, CSA and other applicable codes for power distribution safety.

A common grounding stud or bus bar should be provided within the drive enclosure cabinet, electrically bonded to the metal enclosure.

A grounding wire should be provided directly from the grounding terminal on the OmniPulse DSD drive chassis to the common grounding stud.

A grounding wire should be provided directly from the electrical sub-panel on which the OmniPulse DSD drive is mounted to the common grounding stud. Other electrical equipment, such as fans or relay circuits may be grounded to the electrical sub-panel.

A grounding wire should be provided directly from the hoist motor frame to the common grounding stud.

A grounding wire should be provided directly from the power isolation transformer frame to the common grounding stud.

A grounding wire should be provided directly from building steel to the common grounding stud. If an armature circuit ripple filter is used, a grounding wire should be provided directly from the ripple filter inductor frame to the common grounding stud. The sub-panel for capacitor mounting within the filter should have a grounding wire to the inductor frame.

The secondary side of the power isolation transformer should remain un-grounded.

The low voltage circuit common should be grounded by connecting A1TB1-43 or A1TB1-44 to A1TB11.

Connect terminal G to the common panel ground. Use ground wiring as specified in “Suggested Circuit Protection and Wire Size” on page 22, and keep the length as short as possible.

- Ground Resistance: 230V class; 100Ω (ohms) or less, 460V or greater class; 10Ω (ohms) or less.
- Never run the OmniPulse drive ground wires in common with welding machines, or other high-current electrical equipment.
- When more than one drive is used for the same system, ground each directly or daisy-chain to the ground pole. Do not loop the ground wires.

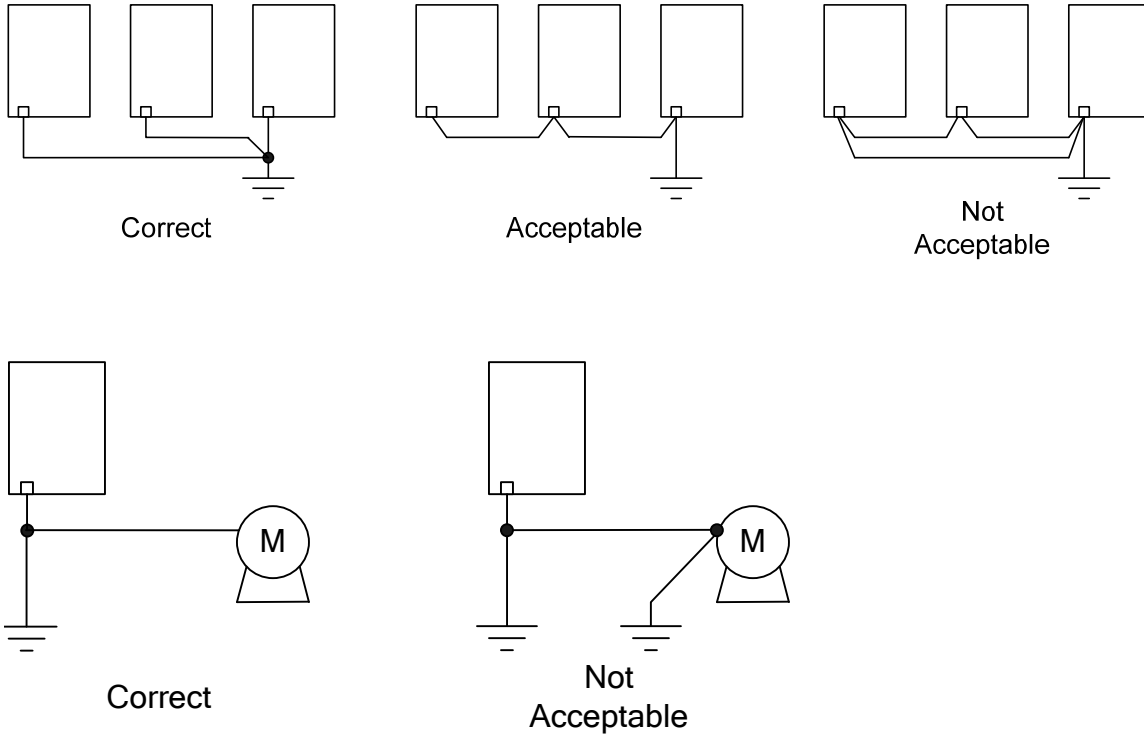

Figure 5: Grounding of OmniPulse DSD Drive and DC Stabilized Shunt

Encoder Wiring

Wiring between the encoder and the OmniPulse DSD drive should be shielded cable with 3 twisted pairs. The pairs should be made up of A and A, B and B, +5VDC and common. The shield should be insulated from the encoder case, and only connected at the drive end, to A1TB1 (6). This cable should be run in a separate conduit between the encoder and the OmniPulse DSD drives.

Pre-power Check



CAUTION

To prevent damage to the drive, the following checks **MUST BE** performed **BEFORE** applying 3-PHASE INPUT POWER to the drive.

- A. Inspect all equipment for signs of damage, loose connections, or other defects.
- B. Ensure the three-phase line voltage is within $\pm 10\%$ of the nominal input voltage range of 150 to 525 VAC. The drive is not sensitive to phase sequence. Input power specifications are contained on the drive nameplate or the drive system Schematic Diagram.
- C. Remove all shipping devices and relay wedges. Manually operate all contactors and relays to ensure that they move freely.
- D. Ensure that all electrical connections are secure.
- E. Ensure that all transformers are connected for proper voltage according to the Drive system Interconnection Diagram.

Drive Start up

Refer to the recommended connections shown in the connection diagrams. Attach a voltmeter across the 115VAC source for the control power supply, at A4TB3-1 & A4TB3-7.

Apply the control and three-phase power and verify that the control power is between 103 VAC and 126VAC. Then press the RESET push button on the front of the power cube, and observe the drive power-up sequence as described below.

Drive power-up sequence

The power up sequence can be observed by monitoring the Standard Control/Display Unit (SCDU) on the front of the power cube.

1. First, all of the segments on the digital LED display and all of the LEDs will light for about 1 second.
2. Then the LEDs and display should extinguish. The drive will perform internal checks. The SCDU will display 'TEST' while a self-test is being performed.
3. If the drive passes the self-test, then the SCDU will display 'P-UP'. READY LED will light.

Abnormal Display Conditions

Displays other than those mentioned above may occur. The following is a list of abnormal display conditions that may occur, and the actions necessary to correct the situation:

4. If no digits or LEDs light up, then check for proper voltage between the 115 VAC control power lines, or for blown 115 VAC control power fuses, or for a defective Control Voltage Power Supply in the power cube.
5. If horizontal segment(s) of the SCDU display are lit, then one or more phases of the three-phase power are missing. Measure and verify three phase power input at the drive terminals. Check the three-phase power fuses. See page 44 for descriptions about the standard control/display unit operation for more detailed information about this test.
6. If the FAULT LED lights and a fault code appears on the SCDU, then refer to the Fault/Error Codes List to see what caused the fault and to find the correct solution. A fault code is the letter 'F' followed by a number representing the fault. See section describing standard control/display unit operation for more detailed information about fault reporting and clearing on page 44.
7. If the SCDU displays 'Prot', then the initial checks found that the protected non-volatile RAM (NVRAM) has not been initialized. Move the NV RAM PROTECTION switch to "OFF" in order to allow the microprocessor to initialize the NVRAM with preprogrammed default values. Notice that the NV RAM UNPROTECTED LED is now lit to indicate the NV RAM PROTECTION switch position. Next, press the RESET push button. The drive will go through its power up sequence again; however, this time it will initialize the unprotected NVRAM and load in factory supplied default parameter values.

Fan Check

On drives with a blower motor (power bridge fan), verify that the fans are working.

Verify Parameters

When the READY LED on the SCDU is lit, all the selectable parameter data should be checked and/or verified to the proper values as follows:

8. VERIFY OR CHANGE EACH PARAMETER VALUE for the particular application and motor involved.
9. Perform PCU DIAGNOSTICS Function 998 should to verify armature and field circuitry.
10. Perform SELF-TUNE PARAMETER TEST Function # 997 to measure and verify various motor parameters essential for proper operation.
11. STORE PARAMETERS, Function # 994, so that power can be removed and reapplied without losing the entered parameters.
12. Set the NV RAM PROTECT switch to the protect position (UN PROT NV RAM light is off) to ensure that set up data cannot be corrupted.
13. Operate drive, using external control signal inputs shown on the Interconnection Diagram.

CHAPTER 4: PROGRAMMING FEATURES

Drive Description

The OmniPulse DSD Drive is a complete digital system drive that provides individual drive and system control in one compact package. It is of 12SCR Regenerative configuration. The drive uses two microprocessors: one for the Power Conversion Unit (PCU) circuitry, and one for the Drive Control Unit (DCU) circuitry. Interface to other equipment is provided with Local I/O [Input/Output]. Extensive diagnostics and setup capability are provided through two Control/Display Units. Depending on rating of the unit, the power cube is in one of four chassis sizes. Refer to the outline dimension drawings. Each power cube is designed for mounting inside a qualified electrical enclosure. Space allowances for air circulation, additional components, outgoing terminals, and wire bends must be provided. Hinged door swing-out clearance is the same as the width dimension.

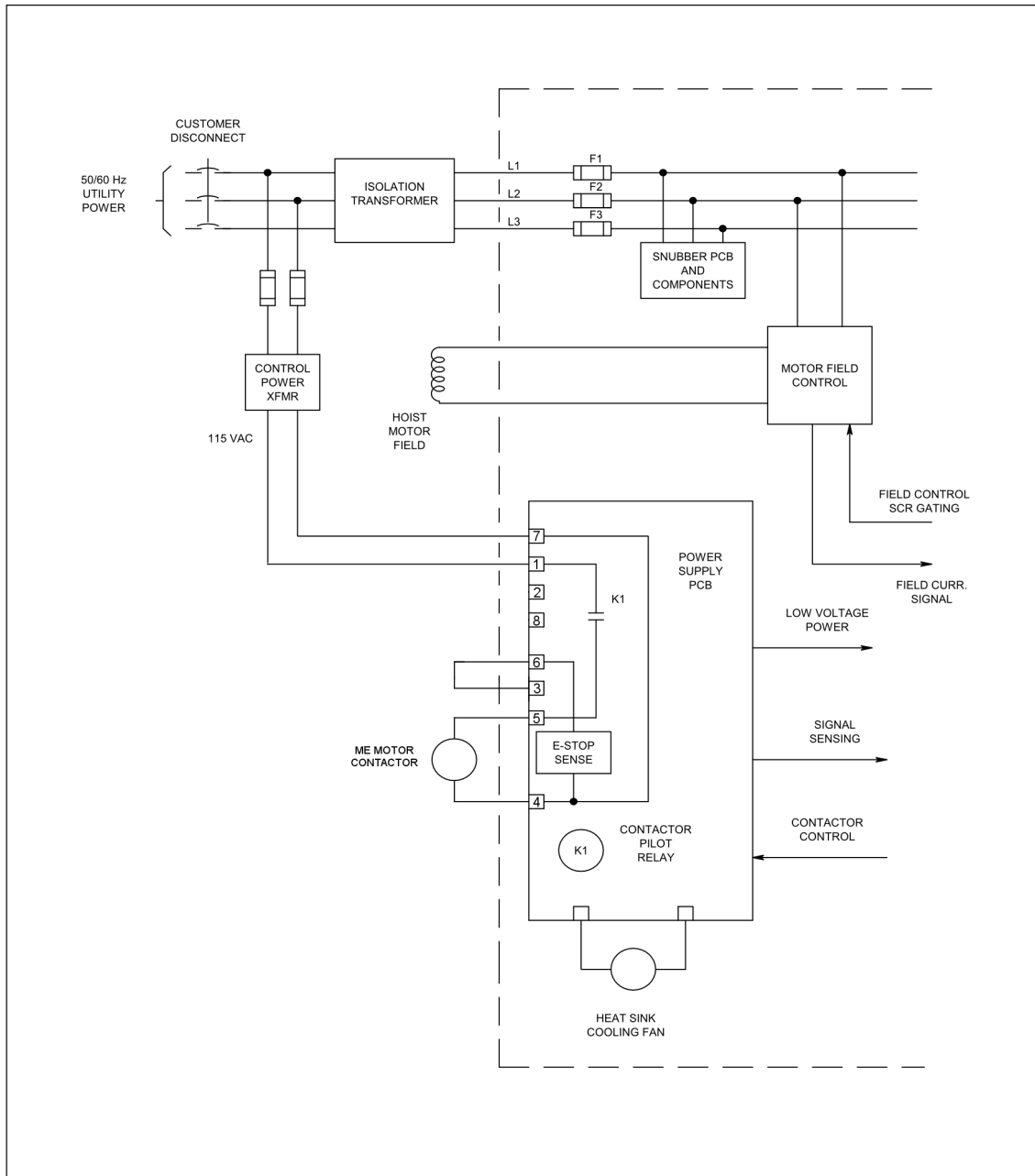

Figure 7: OmniPulse DSD Block Diagram A

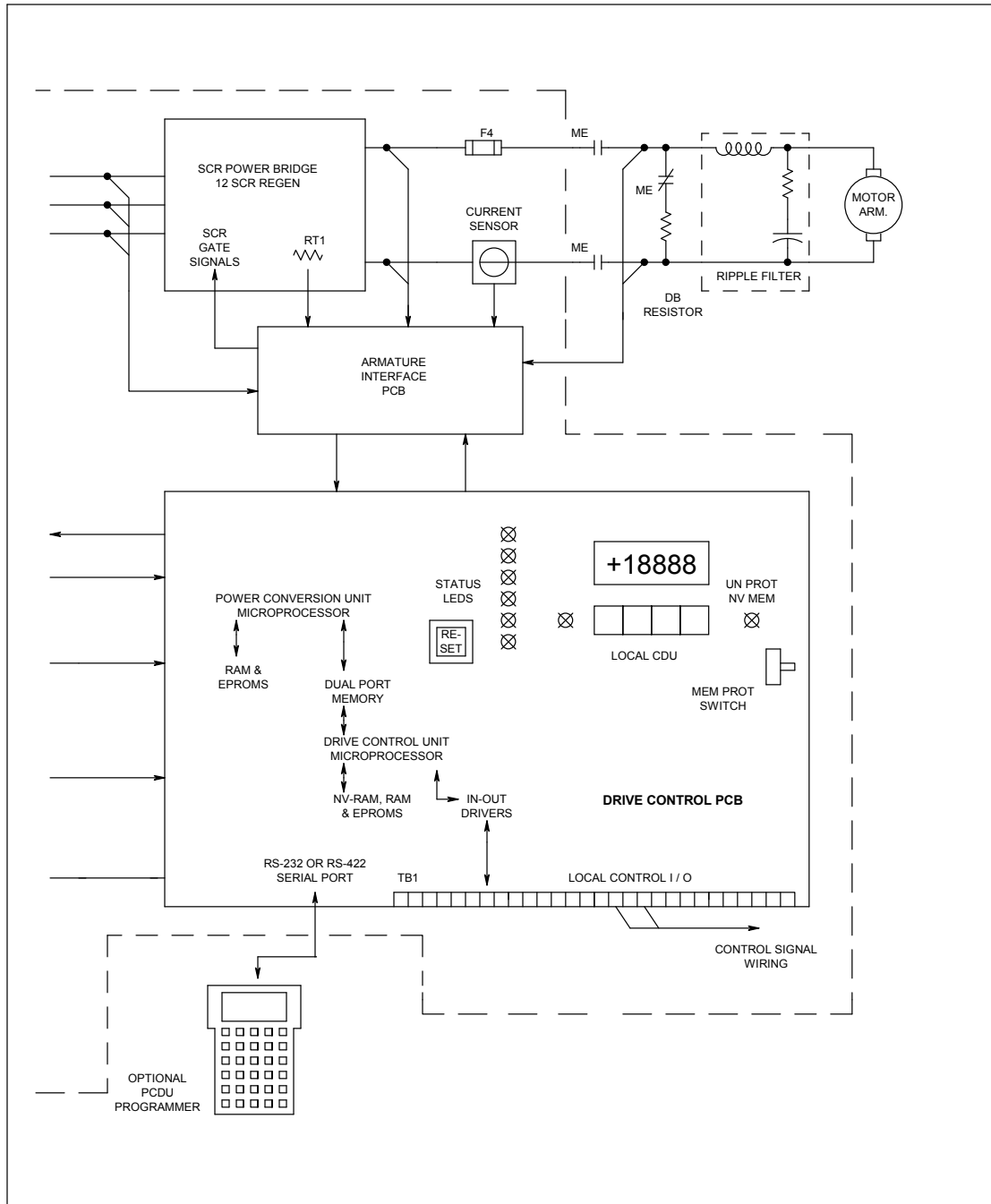

Figure 8: OmniPulse DSD Block Diagram A (continued)

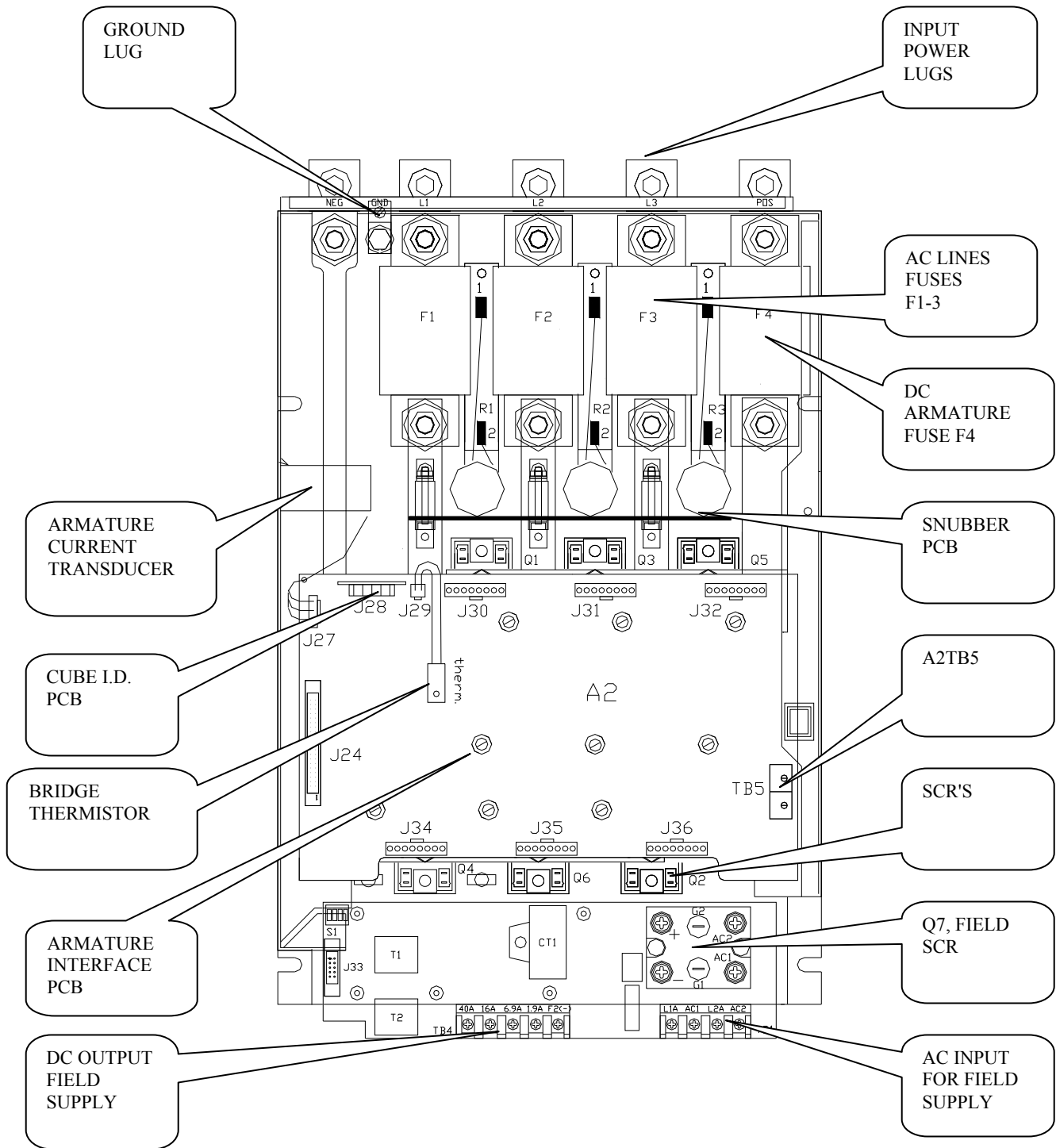

Figure 9: OmniPulse DSD Component Layout Front View

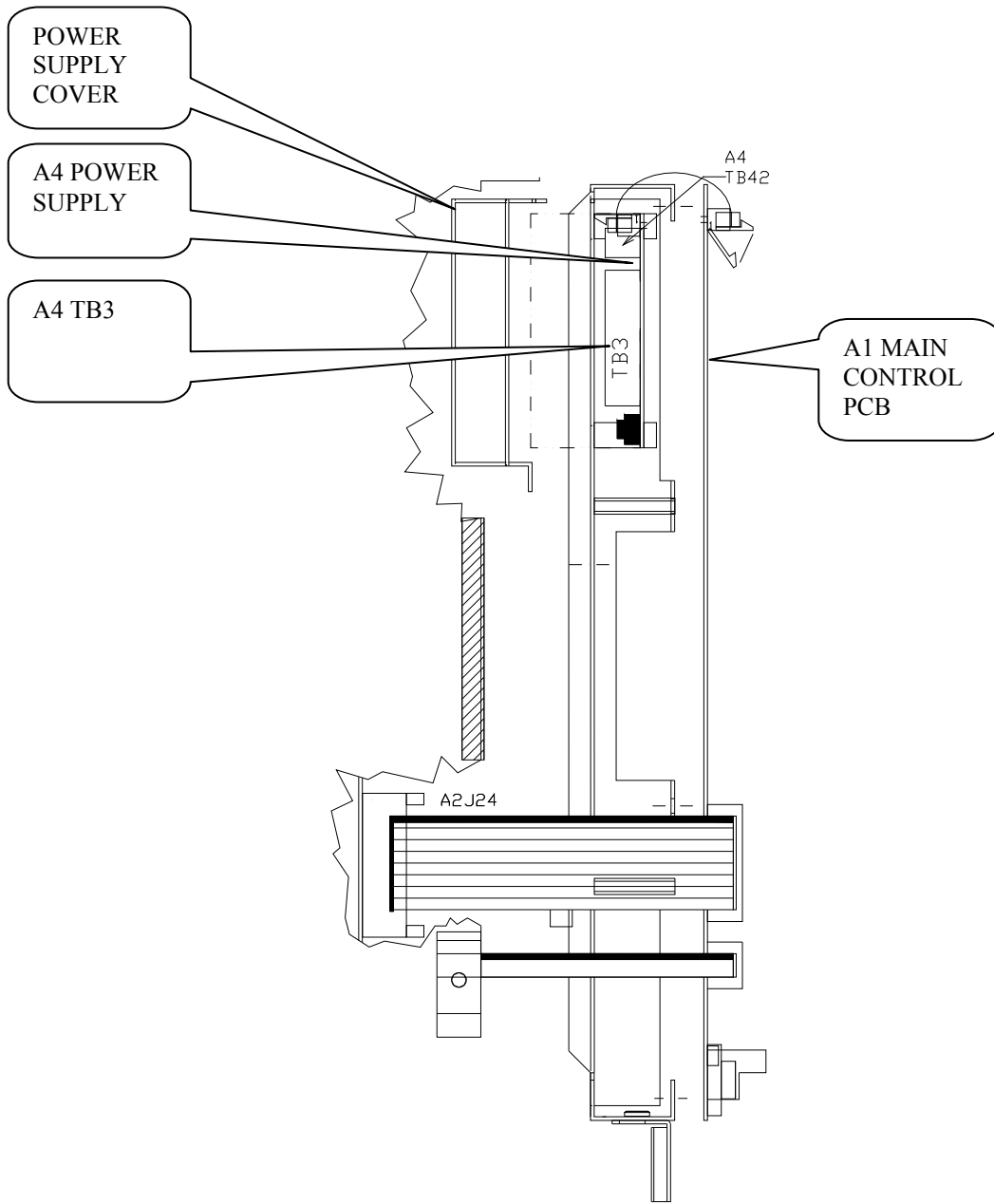

Figure 10: OmniPulse DSD Component Right Side View

The Standard Control Display Unit (SCDU)

The SCDU is mounted on the Drive Control PCB and consists of a 4-1/2 digit numeric LED display, four push buttons and READ/WRITE colored LEDs. The SCDU can be used for all setup functions and many diagnostics.

The Portable Control Display Unit (PCDU)

The PCDU is an optional hand-held device that can be plugged into any analog controlled OMNIPULSE DSD drive and used for all the same functions as the SCDU plus some advanced diagnostics. There is a version of this PCDU which will work with the serial version OMNIPULSE DSD (contact Magnetek for more information). The PCDU has two lines of sixteen alphanumeric characters and a thirty-key keypad. Parameters are entered and displayed in common understandable units. The drive can be completely set up prior to actual running and changes can be made during operation. Keypad entry of changed parameters, protected memory, and factory default values allow the operator to modify data with minimum risk to the process.

Drive Ratings and Specifications

The OmniPulse DSD Drive is designed for connection to a three wire ungrounded power system, or a four wire grounded or ungrounded power system.

Basic Drive Specifications

10-300 Amps (Special order up to 1285Amps or 600VAC)
3 Phase, 48/62 Hz
Service Factor
150% full load current for one minute
250% full load current for 5 seconds
Full-wave six-pulse SCR control
Regulation (of set speed) to 0.05% with digital encoder speed feedback
Current regulated shunt field control
Automatic Field weakening
Self-adapting to incoming line power
Environmental

Service Conditions

Line voltage 150-525 VAC, 3 phase.
115 volt, $\pm 10\%$, 1 phase control power from a separate source
Frequency 48-62 Hz
Operating Temperature 0-45° C (55° C max at OMNIPULSE DSD chassis)
Altitude to 3300 feet above sea level, derate 5% for each 1,000 ft above 3300 ft
Relative Humidity 95% (noncondensing)

Protective Features

Programmed memory protection	Encoder monitoring and loss protection
Self-protected Control V power supply	Input line monitoring
Fast phase-back of loop current	Phase sequence insensitive
Contactors interlock for E-Stop	dv/dt protection (snubbers)
I ² t motor overload protection	1400 PRV Thyristors
AC line current limiting fuses	Instantaneous over-current protection
Automatic power up test	Phase loss protection
Control power supply loss detection	DC bus fuse
Isolated and grounded electronics	Field current economizer and loss protection

Software Operating Features

The OmniPulse DSD DC motor drive is configured by software to operate various crane motions similar to those available when using the Electromotive Systems Impulse AC motor drive. Motor armature power is controlled through double way 6-SCR power conversion from 3-phase utility lines. OMNIPULSE DSD drive hardware provides adjustable power control for the separately excited DC motor field by use of an SCR-Diode component module and a closed loop current regulator. The following features are included in the basic crane control software:

- Self-Tuning to match motor electrical characteristics
- Closed loop 4 quadrant armature current regulator
- Closed loop motor field current regulator with automatic field weakening
- Digital encoder speed feedback
- Run-Up, Run-Down logic control inputs (24 VDC)
- 6 Pre-set operating speeds, plus separately adjustable jog speed
- Automatic Inching Run timer
- External analog speed follower input for PLC or joystick operation
- External analog torque command input for tension control or load sharing
- Adjustable acceleration and deceleration rates
- Adjustable current limit
- Programmable Start-Stop sequencing with or without machine brakes:
 - Coast to stop
 - Controlled Stop
 - No-Load Brake - Automatic sequencing and verification of hoist brake
- Ultra-Lift for faster than normal speed operation at light loads
- Micro-Speed for slow speed positioning
- 9 Programmable multi-function logic inputs (24 VDC) - feature selections include:
 - Pre-set speed selects
 - Slow-down and Stop limits
 - Micro-speed enable
 - Jog & Inch enable
 - Ultra-Lift enable
 - External Fault
 - Fault Reset
 - Brake answer-back
- 7 Programmable multi-function logic outputs - feature selections include:
 - Drive OK / Running / Fault indicators
 - Brake activation
 - Brake Fault Alarm
 - Up / Down / Zero Motion indicators
 - Slow / Stop / Current limit condition indicators
 - Overtemperature / Overload / Low Line Alarms
- 2 programmable analog output channels for data logging or diagnostics
- Diagnostic logic indicators for verification of input and output control signals
- Safety related features and fault traps with diagnostics, including:
 - Blown fuse, Power loss, or Severe power line disturbance monitoring
 - Motor over-load and over-current
 - Motor field malfunction
 - Contactor failure
 - Encoder backwards, over speed, or loss
 - 115 VAC motor thermostat input
 - 115 VAC contactor enable

Power Conversion Unit (PCU)

Description

The Power Conversion Unit (PCU) circuitry has three major functions:

1. It converts three phase AC input power to variable DC voltage for application to a motor armature.
2. It converts motor generated DC power to three-phase power to feed back to the line.
3. It converts single phase AC input power to a variable DC voltage for application to a motor field.

Two sources of power are required. A three-phase power isolation transformer adjusts the utility mains voltage to that required to operate OmniPulse DSD efficiently with the needs of the DC hoist motor. 115VAC control power from a separate source is used to power the low voltage power supply, cooling fans, relay and contactor logic.

Three phase input power is applied through the AC line fuses to twin 6-SCR power bridges for forward and reverse control. The PCU microprocessor controls armature current based on a reference received from the Drive Control Unit (DCU) microprocessor. Output from the PCU microprocessor is sent to the Armature Interface PCB, which produces the gating signals for power SCRs. The SCR bridge output is an adjustable DC voltage, which is applied to the motor armature circuit. Power circuit AC and DC measurement signals are routed to voltage dividers on the Armature Interface PCB, and scaled values are sent to the PCU microprocessor. Armature current is also measured and the feedback signal is routed through the Armature Interface PCB to the PCU microprocessor. An over current trip function monitors this signal to initiate an instantaneous static trip (IST) in the event of excessive output current.

Single-phase power is also applied through the AC line fuses to the Field Rectifier Module. SCR gating signals from the PCU microprocessor control the field rectifier SCRs. A separate current measuring device is used to monitor the DC current flowing to the motor field. Additional connections allow for a separate step-up or step-down transformer to be used to power the motor field rectifier from voltage mains different from that for the motor armature.

If optional dynamic braking resistors (DBR) are present they are applied across the motor armature to dissipate rotational energy whenever the motor contactor is dropped out. This helps to bring the motor to a stop even when utility power is lost.

The largest component of the PCU is the SCR bridge (heatsink assembly). The heatsink is an extruded aluminum structure that dissipates the heat generated by the SCRs mounted on the front surface (or between heatsink sections, in large size power cubes). The SCRs control the current to the motor armature and in turn are controlled by the Armature Interface PCB mounted in front of the SCRs. Three input power line fuses are provided. A DC Bus fuse protects the motor armature circuit. A thermistor (and thermostat on some ratings) senses heatsink temperature and gives an over-temperature warning if an over-temperature occurs.

Access to the SCR Bridge is obtained by opening the hinged door containing the Drive Control PCB A1.



WARNING

Opening the hinged door with power applied to the drive exposes dangerous voltage levels. The hinged door should only be opened by a qualified service technician, and only when the power to the drive is turned off.

Hardware Description

OmniPulse DSD Power Supply PCB (A4)

Provides +5V, +15V, -15V, and +24V to the control circuits and has fold-back current limit protection. It also provides 115VAC connections for the main contactor, motor thermostat and fans.

Armature Interface PCB (A2)

Provides the interface circuitry between the digital firing pulses generated by the Drive Control PCB and the high current SCR gating pulses controlling the armature current. It also provides feedback signals from the power section to the Drive Control PCB. A small 'cube ID' circuit board is attached to the Armature Interface PCB to identify the ampere capacity of the SCR power bridge to the PCU processor.

SCRs

The drive uses different selections of doubler packs or individual "hockey puck" SCRs according to the horsepower ranges specified below:

MOTOR ARMATURE CURRENT	SCR TYPE
25A - 195 A	Doubler
300 - 1285 A	"Hockey Puck"

Field Interface PCB (A3)

Provides the interface circuitry between the digital firing pulses generated by the Drive Control PCB and transformer isolated SCR gating pulses controlling the field current. It also contains the field feedback circuitry and the field SCR snubber circuit.

Cell snubber PCB (A5)

Provided for SCR protection. These are selected to work efficiently with utility line impedance between 2 and 8 percent, including that of the power input transformer.

Drive Control PCB (A1)

Mounted on the hinged door, this board provides the microprocessors, memory and support circuits needed to control drive operation. Two control circuits are provided on this PCB: one for controlling the Power Conversion Unit (PCU), and another for speed regulation and higher-level functions, called the Drive Control Unit (DCU). These two circuits communicate primarily through a Dual-Port Random Access Memory (DPRAM) IC (integrated circuit) device.

Drive Control Unit

The major element of the DCU is a 16/32-bit Motorola 68000 microprocessor. Random Access Memory (RAM) provides memory space to store values that are maintained only while power is on. Non Volatile Random Access Memory (NVRAM) maintains drive control parameters for the DCU when the power is off. Two EPROM's (Electrically Programmable Read Only Memory) devices, U39 & U40, contain the specific drive program instructions for the DCU microprocessor.

Power Conversion Unit Control

The major element of the PCU control circuit is a 16-bit Intel 80C196 microprocessor. Again, RAM and EPROM devices, U13 & U14, provide memory space and computer instructions for the PCU. Any PCU parameters that need to be maintained while power is off are kept in NVRAM of the DCU and passed through the DPRAM.

Local I/O

In a Material Handling application, the Local I/O [Input/Output] allow the drive to have inputs and outputs (I/O) such as RUN, STOP, Encoder Feedback, Analog Reference Input, Fault condition relay logic output, etc. connected directly to the drive.

Front Panel Controls and Indicators

The upper right corner of the power cube cover contains the operator controls and indicators. Although accessible with the cover in place, all of these components are part of the Drive Control PCB (A1).

DRIVE RESET Button (S1)

Pressing this button causes the drive to clear critical and non-critical faults and to restore drive operation when faults are present. This button will have no affect when the drive in enabled.

Status LEDs

Located to the right of the RESET button is a vertical strip of six light emitting diodes (LEDs):

READY — Indicates that the drive is ready to run.

RUN — Motor contactor is closed and drive is controlling motor speed.

I LIMIT — Drive operation is demanding current limit armature current.

OVERLOAD — Motor armature current is in overload region. If lighted when the drive is stopped, indicates that an over-load trip has occurred.

E-STOP — Drive contactor safety interlock is detected open. Drive will not run when this light is on.

FAULT — Indicates that a declared drive fault exists. The Fault/Error Code List defines what conditions the drive will recognize as faults.

Standard Control Display Unit

The major part of the SCDU is a 4-1/2-digit numeric LED display. Each of its four full digits can display the values of 0 to 9 plus limited alphabetic characters. The so-called half digit can display only the value 1 and a plus or minus sign. Underneath this display are a green LED (labeled DATA), a red LED (labeled DATA PEND), and a row of four push buttons.

The DATA and DATA PEND LEDs are used to indicate the significance of the LED display data, and the four push buttons (DATA/FCTN, > [UP], > [DOWN], and ENTER) are used to operate the SCDU.

Non-Volatile RAM Protection

To the left of the four push buttons of the SCDU there is a red LED labeled MEM UNPROT. This LED is lit when the "protected" portion of the non-volatile random access memory (NVRAM) can be written to. The switch labeled S3, which is located just under the MEM UNPROT LED, determines protection of the NVRAM. When this switch is in the "ON" position, the NV RAM UNPROTECTED LED is off and the protected portion of the NVRAM cannot be written to. This prevents setup parameters and other important constants from being accidentally erased or changed. When these parameters need to be changed the switch can be moved to the "OFF" position, removing the write protection and causing the NV RAM UNPROTECTED LED to be lit. Refer to the section described as saving parameters.

The NV RAM PROTECTION switch should be left in THE "ON" position (UN-PROTECTED NV MEM LED OFF) to protect the NVRAM during the critical power-up and power-down periods.

Interface Specifications

OmniPulse DSD is designed to interface with isolation relays to input and output devices.

The drive has eleven logic programmable input terminals, which can be used to connect with the user input device. Terminals 49 and 8 are always used for the directional run commands (Forward and Reverse, Up and Down). The rest of nine terminals are multi-function terminals, and are used for speed control and other characteristics. With multi-function terminals you can assign various functions and performance characteristics without having to rewire the drive.

There are two preset function analog inputs: Each is selectable between 0-10 or ± 10 VDC input. One is speed reference and the other is torque reference.

The drive has programmable multi-function logic output. Three are 115VAC, 500mA relay contacts. Four are open collector multi-function output terminals.

The drive has two programmable analog output channels for data logging and diagnostics.

Standard Control/Display Unit Operation

General

The Standard Control/Display Unit (SCDU) is used to change and/or monitor various drive dependent operational set points and perform diagnostics for the Magnetek OmniPulse DSD Drive. The SCDU is located in the upper right corner of the Drive Control PCB and is accessible through the power cube cover. This Control/Display Unit is present on every Magnetek OmniPulse DSD Drive.

The SCDU consists of a 4-button keypad, a 4-1/2 digit numeric LED display, red and green colored LEDs, an "NVRAM PROTECT" switch (marked NV RAM PROTECTION on the power cube cover), and a red LED that shows the status of the "NVRAM PROTECT" switch.

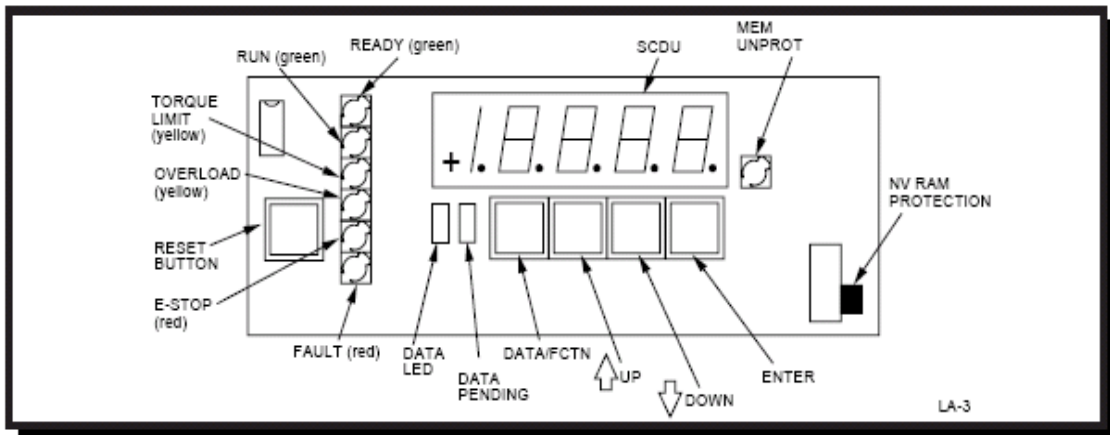

Figure 11: OmniPulse DSD Standard Control/Display Unit

Start-Up Operation

When power is first applied to the drive, *all of the segments on the 4-1/2-digit display will turn on briefly in order to show that all are functioning:*



■ ■ Both LEDs Off

After this lamp test is completed, an internal check is made to determine if the NVRAM chips have ever been used before, or if the EPROMs are the same as before power down. If not, the drive software will attempt to load the defaults into the NVRAM chips. *The SCDU displays the word 'Prot' if the NVRAM PROTECTION switch is in the position that will not allow any updates of the NVRAM:*



■ ■ Both LEDs Off

If the display shows 'Prot', it is necessary to move the NV RAM PROTECT switch to the "OFF" position and press the CPU RESET button in order to load defaults into NVRAM and restart the drive. Then set the NV RAM PROTECT switch back to "ON". This 'Prot' message will only happen when: the drive is powered up for the very first time; if the software in the drive is changed; or the NVRAM chip (U56) is changed.

After the LED lamp test has completed, the drive software will now perform a fuse test on each of the three line fuses. If any power conversion fuse is open, the SCDU will indicate this on its display. The SCDU display is arranged in a similar manner to the physical placement of the 3 line fuses in the power cube. The middle segments of the three right-most digits are used to indicate blown fuses. For example, if the left-most line fuse is bad, the SCDU will report it as follows:



■ □ Red LED Lit

If any two or more fuses are blown, the SCDU display will be:



■ □ Red LED Lit

The operator should then identify which fuses have failed.

The drive will not operate unless all three line fuses are functional. If the SCDU indicates a bad fuse, power must be removed from the drive, the fuse replaced and power reapplied.

After the drive has performed all three tests (lamp test, RAM test, and fuse test), the SCDU displays one of two final messages. If there are any faults present at this time, the SCDU will display a Fault code. The display will be *similar* to:

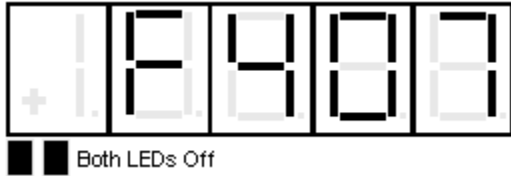

where the leading 'F' indicates a fault and the 3 digits following the 'F' indicate the fault number. If however, there are no faults present, the SCDU displays the normal power-up message:

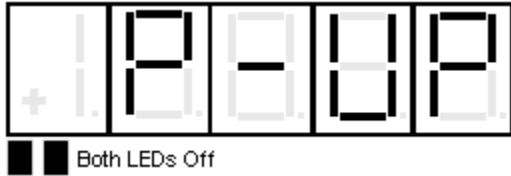

This 'P-UP' display will remain on the SCDU until a key is pressed or a fault occurs.

After Power-Up

After the drive has powered up and the SCDU display is showing 'P-UP' or a fault number, it can be used to enter new parameters, monitor drive operation, and/or perform certain drive diagnostics. *Every operation that the SCDU can perform is called a 'function'*. There may be up to 1000 functions defined within the DCU.

All SCDU functions have at least 2 levels, and some functions use 3 levels. The two colored LEDs below the lower left corner of the 4-1/2-digit display are used to indicate which level of a particular function the SCDU is currently at. The top level of the SCDU operation is called the "Function" level. *The two colored LEDs are off when the SCDU is in the "Function" level.* The ▲ or ▼ keys are used to select a function number to be accessed while at this level. The ▲ key increments the function number in the display while the ▼ key decrements it. The SCDU will ramp the displayed function number when the ▲ or ▼ key is pressed and held for 1/2 second or longer.

The DATA/FCTN key is used to toggle between the "Data" level and the "Function" level. Press the DATA/FCTN key when the desired function number is in the display. At this point, the SCDU leaves the "Function" level and enters the "Data" level. Note that the green LED is now lit. This operation is consistent for every function on the SCDU, although the data actually displayed while the LED is GREEN is function-number specific. Examples of every type of SCDU function are given in subsequent sections. All function numbers are shared between the SCDU and the PCDU (Portable Control/Display Unit). *There are some functions, however, that can only be performed with the PCDU. When such a function number is selected on the SCDU and the DATA/FCTN key is pressed, the SCDU's display will change to:*

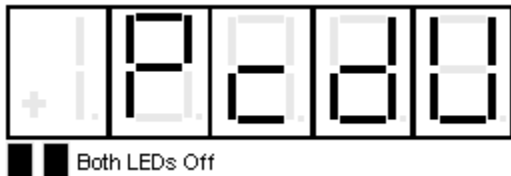

Changing Parameter Functions

SCDU functions are used to modify and/or display setup points that the drive needs for operation. Items that would typically fall into this category are functions such as Accel Times, Regulator Gains, Rated Speed and any other parameters. The following steps show how to modify a given parameter via the SCDU display.

- 1) Use the ▲ and ▼ keys to select the function number to be accessed. The two colored LEDs remain off during this step. For example, if #040 is chosen:



■ ■ Both LEDs Off

- 2) Press the DATA/FCTN key to enter the "Data" level for this function number. The green LED is lit to indicate that the number being shown is the current actual value for this parameter. For example, if Function # 40 is currently set for a value of 10.6, it will be displayed as:



■ ■ Green LED Lit

- 3) Use the ▲ and ▼ keys to ramp the number in the SCDU display to the desired value. Note that the red LED is lit to indicate that the value being displayed is NOT the actual value, but rather is in the process of being changed. Each parameter has an upper and lower limit. *The following display will occur when the lower limit is exceeded:*



■ □ Red LED Lit

Similarly, if the upper limit is exceeded, the SCDU displays:



■ □ Red LED Lit

The SCDU display will increment from '10.6' to '11.0' if the ▲ key is pressed 4 times:



■ □ Red LED Lit

- 4) Press the ENTER key to transfer the value in the SCDU display to the actual value used by the drive. Note that the green LED will now light to indicate that this value is now the actual value for this parameter:



□ ■ Green LED Lit

If the ENTER key is pressed while the display is indicating that the upper or lower limit has been exceeded, the display will change to the appropriate limit and the green LED will light.

- 5) Press the DATA/FCTN key to put the SCDU back into the "Function" level. As with the example above, the SCDU display will be similar to:

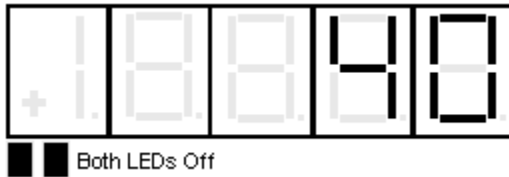

All changes made become active values upon pressing the ENTER key. They remain active until the next reset, or until the drive is powered down. When the drive is reset or powered up the value reverts to the value stored in NVRAM. If changes are to be permanent, use Function # 994 to save the changed value in NVRAM.

Due to programming considerations it may be possible to access a value that cannot be changed. In this case the CDU function will proceed as described until the ENTER key is pressed to change the value. In this case the value will simply ignore any requested changes and remain the same.

Viewing Monitor Functions

Items that would typically fall into this category are Speed Feedback, Armature Current and Armature Voltage.

To view one of these values, it must have been previously programmed in the drive. The following steps show how to display a given value on the SCDU display.

- 1) Use the ▲ and ▼ keys to select the function number (between 600 and 799) to be accessed. The two colored LEDs remain off during this step. For example, if 600 is selected, the SCDU display will be:

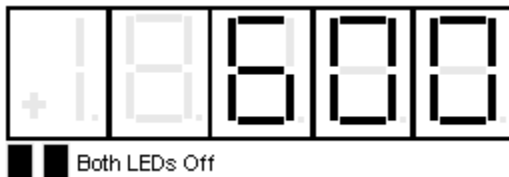

- 2) Press the DATA/FCTN key to enter the "Data" level for this function number. The green LED is lit to indicate that actual data is currently being viewed. If the data for Function # 608 is currently at 20.94 for example, the SCDU display will change to:

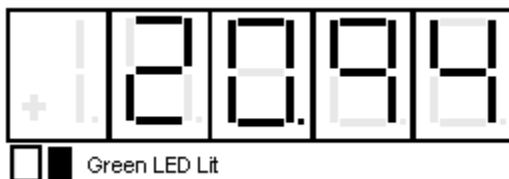

The SCDU's display is updated immediately if the value for the selected function changes.

NOTE: Values displayed with these function numbers cannot be modified.

Error Reporting

The drive has two methods available to report errors and faults. Each error condition may utilize ONE, BOTH OR NEITHER of the reporting methods.

The most conventional method is called 'fault recording'. If this method is enabled for a particular error, the red FAULT LED and a unique fault code number will appear on the SCDU at the moment the error occurs. Each fault occurrence is recorded in a RAM location called the Fault List. The Fault List stores the 16 OLDEST faults and *stops recording faults* as soon as the 16th fault occurs. *This list is erased when the drive is powered down or reset.* Whether or not the drive stops or continues to run is dependent on the way the particular fault is implemented. Most standard faults are set up so that the drive will stop if a fault occurs. Faults stored on the Fault List will appear when viewing Function # 0.

The second method for error handling is called 'error recording'. Error recording differs from fault recording in three respects:

- The error condition *will not* be shown on the SCDU or the red Fault LED.
- The error list stores the 16 most recent errors and *always* overwrites the oldest error with the newest error.
- This list is maintained in battery-backed-up RAM and is retained when the drive is powered down or reset. Operation of the drive is totally independent of whether error recording is enabled or not.
- The Errors List may be viewed at Function # 800.

Function # 801

Used to display or alter the Fault & Error Disposition List. This list is consulted any time an error condition occurs to determine whether it should be reported as an error, a fault, or both. The process for changing the entry in the disposition list for a particular error using the SCDU is as follows:

- 1) Use the ▲ and ▼ keys to select function number # 801 from the function level. The two colored LEDs remain off during this step.

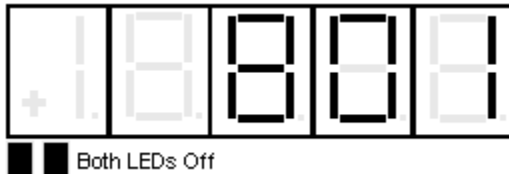

- 2) Press the DATA/FCTN key to enter the "Data" level for Function #801. The green LED will light and the error code last modified, with Function #801, will be in the SCDU display. The SCDU displays error code #13 (illegal instruction) initially:

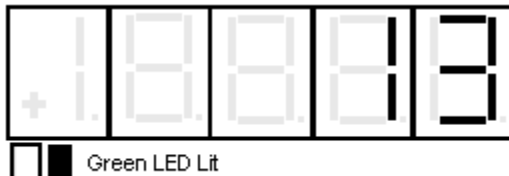

- 3) Use the ▲ and ▼ keys to select the error code entry in the Disposition List that is about to be changed/viewed. For example, if the disposition for error code 102 (Numeric Underflow) is to be modified, press the key until the SCDU display changes to:

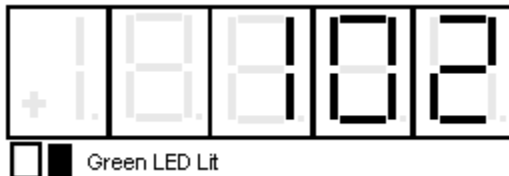

- 4) Press the ENTER key when the desired error code is displayed on the SCDU. The red LED now lights and the SCDU display changes as well to a format of 'E.xF.y'.

The 'E' and 'F' are abbreviations for Error and Fault respectively. The 'x' and 'y' will be either '1' or '0' to indicate which list will record the error. For example, if the display is 'E.1F.1', the error is recorded in both lists. If the display is 'E.0F.1', the error is recorded in the fault list, but not in the error list. If the display is 'E.0F.0', *neither* list records the error. In the example above, the factory set default disposition for a numeric overflow F#102 is to record the error in the Error List, but not in the Fault List. In this case, the SCDU display is:

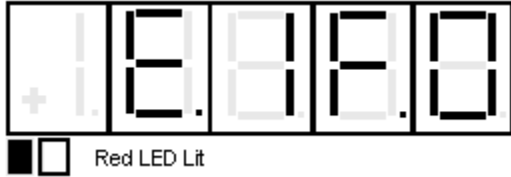

- 5) Press either the ▲ or ▼ key repeatedly to change the numbers after the 'E' and 'F' from '1' to '0' and vice-versa. Starting from no declarations, the displays are: 'E.0F.0', 'E.0F.1', 'E.1F.0', and 'E.1F.1'. For example, if the disposition for this error should be changed so that it is *NOT* recorded in either the Fault or Error list, press the ▼ key once so the display changes to:

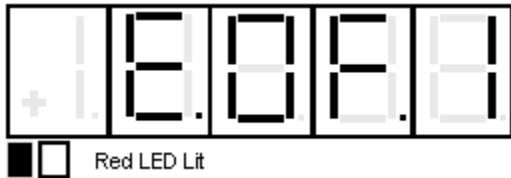

This display indicates that the Numeric Underflow error will now be recorded in the Fault List, but not in the Error List.

Pressing the ▼ key once more will change the display to:

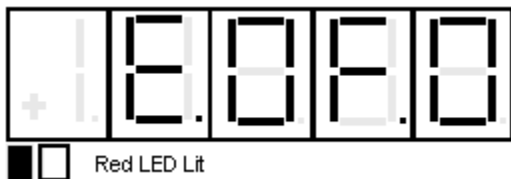

This is the desired status for the new disposition of the Numeric Underflow error, which is to *not* report it to either the Fault or Error List.

- 6) Press the ENT key when the new disposition code is in the display. At this point, the green LED will light, and the SCDU displays the error code again:

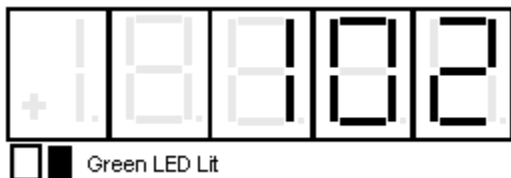

The ▲ and ▼ keys can now be used to select another error code to be modified, as in step 3.

- 7) When all changes in the Error Disposition List are finished, pressing ENTER key will exit back to the function level:

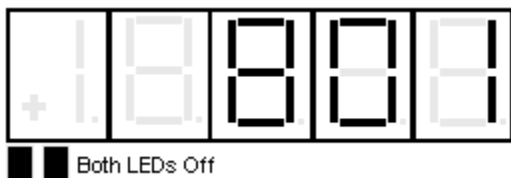

Fault Display/Clear

The drive stores the first 16 faults that have been reported to the Fault List, **Function # 0**. Once the Fault List is filled with 16 faults, it will not accept any more entries. *The data in this buffer is not retained when the power is lost.* Each time a fault condition occurs, and its entry in the Disposition List is set to also record in the Fault List, the new fault is placed on the list (provided the list is not full).

Function # 0

Reserved for viewing the Fault List. The steps to view the Fault List are as follows:

- 1) Use the ▲ and ▼ keys to select Function # 0. The two colored LEDs remain off during this step. Note that simply pressing the ▲ key once can access this function, if the SCDU display is 'P-UP'.
- 2) Press the DATA/FCTN key to enter the "Data" level for this function. The green LED is now lit to indicate that the fault codes currently in the Fault List are being displayed. The very first display at this point is the word 'ALL':

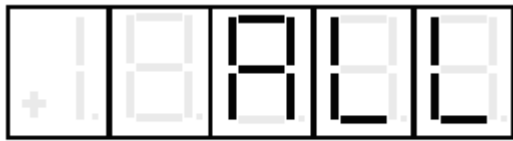

■ ■ Both LEDs Off

The SCDU display always displays the fault code that will be removed if the ENTER key is pressed. If the ENTER key is pressed at this time, *every fault currently in the Fault List will be removed from the list.*

Each fault in the Fault List can be shown on the SCDU display and optionally cleared.



IMPORTANT

The process of clearing a fault from the Fault List *DOES NOT* actually clear the condition that caused the fault.

To view the first fault on the list, press the ▲ key. If there is a Numeric Underflow fault 102 is on the Fault List, for example, the SCDU display will change to:



□ ■ Green LED Lit

The contents of the Fault List may be examined by using the ▲ and ▼ keys. The ▼ key moves down the fault list while the ▲ key moves up the fault list. The first fault in the list is the first fault actually declared. The SCDU displays the word 'End' *after the last fault has been displayed*:



□ ■ Green LED Lit

Error Display

The drive is able to store the most recent 16 errors that have been reported to the Error List. This list is constantly updated, *with the newest error overwriting the oldest in the list*. This list is held in battery-backed-up RAM (NVRAM), so it is retained when power is lost. Each time an error condition occurs, and if its entry in the Disposition List is set to allow recording in the Error List, that new error is placed in the list.

Function # 800

Reserved for viewing the Error List in NVRAM. The steps to view the Error List are as follows:

- 1) Use the ▲ and ▼ keys to select Function # 800. The two colored LEDs remain off during this step.



■ ■ Both LEDs Off

- 2) Press the DATA/FCTN key to enter the "Data" level for the view error function. The green LED is now lit to indicate that an error code is currently being viewed. If the error in this slot is a Numeric Underflow fault 102 for example, the SCDU will display:



■ ■ Green LED Lit

Other errors currently in the Error List can be viewed by pressing the ENTER key to display the Error Code again, then use either the ▲ or ▼ key to move to the next slot in the list. The procedure outlined above should be repeated as necessary to view the Error Code number for other errors in the Error List.

Non-Volatile Ram Access

Every parameter that the drive uses has three separate areas in memory associated with it. There is a factory-set default value for each parameter which is stored in the "read only" EPROM chips. There is an area in the active RAM which the drive uses while it is running. There is also an area in NVRAM reserved for each parameter. The values in the NVRAM area are copied to the active RAM every time the drive is powered up or the reset button is pressed. This split level approach makes it possible to return to the last set of 'stable' parameters in NVRAM if some errors are made during fine-tuning of the active drive parameters. The purpose of this function is to perform transfers between the NVRAM parameter list and the active parameter list.

Function # 994 is used to perform the transfer of data between the NVRAM and active parameter lists. The process for copying data to or from the NVRAM parameter list is as follows:

- 1) Use the ▲ and ▼ keys to select Function # 994 from the function level. The two colored LEDs remain off during this step.

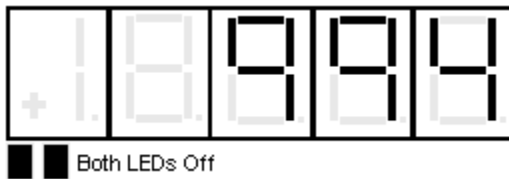

- 2) Press the DATA/FCTN key to enter the "Data" level for Function # 994. The green LED is now lit to indicate that this function is currently being accessed. It is possible to SAVE the current active parameters in RAM to the NVRAM parameter list, or to RESTORE the current parameters from the NVRAM parameter list to ACTIVE RAM. *Note that a RESTORE is the same operation that occurs inherently every time the drive is powered up.* Upon entering the data level for this function, the SCDU displays:

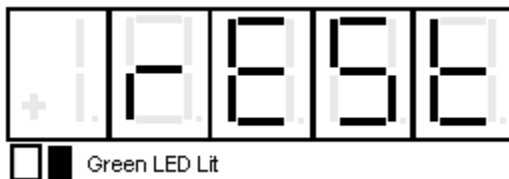

The ▲ and ▼ keys can be used to toggle between the above display, which indicates a pending RESTORE operation, and the following display, which indicates a pending SAVE:

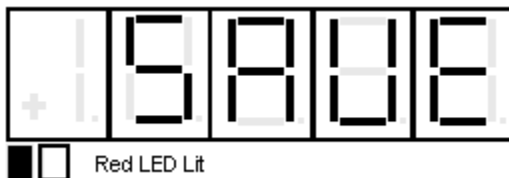

Note that as soon as either the ▲ or ▼ key is pressed, the red LED will light.

- 3) Press the ENTER key to actually perform the transfer of data. If ENTER is pressed while 'SAVE' is displayed, the SCDU display may change to:

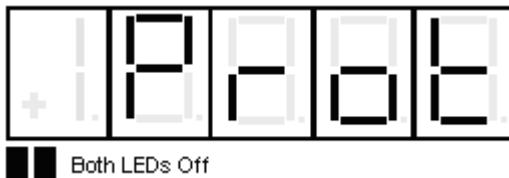

This display means that the NV RAM PROTECTION switch is in the incorrect position preventing writes to the NVRAM. Move the switch to the "OFF" position, press the DATA/FCTN key, and start over from step 2.

If the SAVE or RESTORE operation was successful, *the green LED will light*. For example, if a SAVE were performed, the display would be:

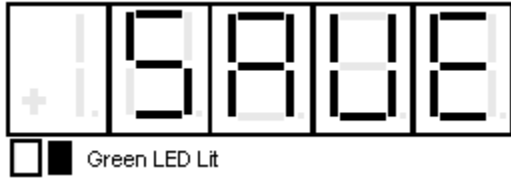

Load Default Function

Every parameter in the drive has a factory-set default value that is loaded when the drive is powered up for the very first time. These default parameters may not be optimal values for the drive when actually running, but they will generally allow the drive to function. It is possible to reload these default parameters with **Function # 995** of the SCDU. A re-load of the defaults would generally be done when the drive is operating erratically and it is suspected that one or more parameters were improperly set.

CAUTION

Use of the LOAD DEFAULTS function will overwrite EVERY parameter currently being used by the drive with the factory set default for each parameter. There is no way to restore parameters to their previous value once this function is used.

Function # 995 is used to perform the transfer of data from the default parameter list to the ACTIVE RAM parameter list. The process for accessing the Load Defaults Function is as follows:

- 1) Use the ▲ and ▼ keys to select **Function # 995** from the function level. The two colored LEDs remain off during this step.

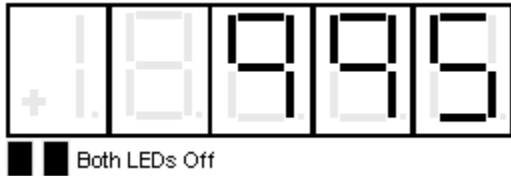

- 2) Press the DATA/FCTN key to enter the "Data" level for Function # 995. The green LED is now lit to indicate that this function is currently being accessed. The SCDU will now display:

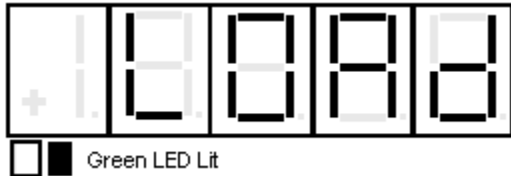

- 3) Press the ENTER key to actually perform the Load Defaults transfer. After the transfer has completed, the SCDU displays the word 'dOnE':

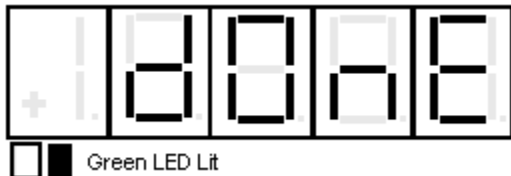

- 4) A cycling of control power is then necessary to implement the default settings onto the display.

Self Tune Function

The OMNIPULSE OmniPulse DSD drive has a built-in current regulator SELF TUNING Function # 997. When activated, this feature measures total motor armature circuit resistance, inductance including wiring, and the field L/R time constant. The drive then uses the measured value in conjunction with the parameter entered for "CROSSOVER FREQUENCY" to calculate integral and proportional gains for the current regulator and to set the field regulator gains properly. After running the Self Tune Parameter Measurement function, the values for armature resistance and armature inductance are stored in NVRAM. It is important to note that it is possible to override the values that have been dynamically calculated for Armature Resistance, Armature Inductance, and Field L/R Time Constant by the "USE SELF-TUNE" item in the parameter menu (Function # 20). The dynamically calculated values are used if "USE SELF-TUNE" is set to "ON" while the *manually entered* values (entered in parameters 4, 5, and 8) are used if this item is set to "OFF".

NOTE: Armature current is circulated through the armature circuit during parts of the PCU Parameter Measurement function. The PCU will reduce the field current to zero on motors with a shunt field in order to minimize motor rotation. If the PCU detects significant motor voltage during the test, the PCU parameter measurement function will abort



IMPORTANT

It is important to note that when applying a LRC output filter (Ripple Filter), the drive performance will be affected. For this reason, it is necessary to run the SELF-TUNE test with the *output configuration that will be used*. For example, if the filter is used with the capacitor fuse installed, then the SELF-TUNE test must also be run with the filter fuse installed. If the capacitors are not needed, then the fuse should be pulled and the SELF-TUNE test should be run with the fuse pulled.

The process for accessing the PCU PARAMETER MEASUREMENT function is as follows:

- 1) Use the ▲ and ▼ keys to select Function # 997 from the function level. The two colored LEDs remain off during this step.



Both LEDs Off

- 2) Press the DATA/FCTN key to enter the "Data" level for Function # 997. The green LED is now lit to indicate that this function is currently being accessed. The SCDU displays the word 'Prot' if the NV RAM PROTECTION switch is in the position that will not allow any updates to the NVRAM:



Both LEDs Off

If the 'Prot' message appears, press the DATA/FCTN key to return to the "Function" level, move the NVRAM PROTECTION switch to the "OFF" position, and press the DATA/FCTN key again. The SCDU will jump to step #3 when the NVRAM PROTECTION switch is in the correct position upon entering this function.

- 3) The SCDU displays the word 'Entr' to prompt the user to press the ENTER key as further confirmation that the PCU parameter measurement function is about to be performed:

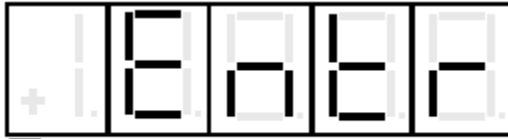

Green LED Lit

- 4) Press the ENTER key to actually start the PCU Parameter Measurement function. The PCU *will not* begin the measurement routine if a SEVERE PCU FAULT exists. The PCU will declare a SEVERE FAULT under several conditions including an IST fault, power supply failure, line sync loss, low line, or DCU failure. If a SEVERE FAULT exists when the PCU starts the parameter measurements, the SCDU displays:



Green LED Lit

Severe faults can only be cleared by pressing the reset button on the Drive Control PCB, by cycling power to the drive, or by replacing the bad component if applicable. The SCDU displays the word 'tEst' while it is performing the parameter measurements and there were no SEVERE FAULTS when the ENTER key was pressed:



Green LED Lit

- 5) Press the DATA/FCTN key to **exit the PCU parameter measurement routine and return to the "Function" level. The SCDU displays:**



Both LEDs Off

- 6) After completion of SELF-TUNE, enable Function # 20 (unless using manual entry).

Power Conversion Diagnostics

The drive has built-in diagnostic routines that can be performed via the SCDU. The PCU diagnostic routines are able to test for four failure modes. The first test that the PCU performs is a test of the three line fuses. Assuming the three line fuses are all OK, the PCU then performs a test for shorted SCRs/doubler packs. If this test indicates no shorted SCRs/doublers, the PCU then verifies that less than 5% of the value entered for "Rated Field Current" is attainable. The PCU then tests for open SCRs by passing current through the forward bridge followed by the reverse bridge, and finally checks polarity of voltage feedback. The result of the test is displayed on the SCDU after the test completes. The SCDU will light certain unique LED patterns on its display corresponding with the failure (see displays in the procedure that follows). The Fault Codes F910 (Blown Fuse), F911 (Shorted SCR), F912 (Open SCR), and F917 (Reverse Armature Feedback Wires) will not appear on the SCDU if the Error Disposition List is programmed so that they are not reported to the Fault List.



WARNING

Armature current is circulated through the armature circuit during parts of the PCU Diagnostics Function. The PCU will reduce the field current to zero on motors with a shunt field in order to minimize motor rotation. However, a PERMANENT MAGNET motor must have its shaft locked mechanically prior to running the PCU Diagnostics routine. If the PCU detects significant motor voltage during the test, the PCU Diagnostics Function will abort.

The process for accessing the PCU Diagnostics Function is as follows:

- 1) Use the ▲ and ▼ keys to select Function # 998 from the function level. The two colored LEDs remain off during this step.



■ ■ Both LEDs Off

- 2) Press the DATA/FCTN key to enter the "Data" level for Function # 998. The green LED is now lit to indicate that this function is currently being accessed. The SCDU prompts the user to press the ENTER key by displaying:



□ ■ Green LED Lit

- 3) Press the ENTER key to actually start the PCU diagnostics. While the PCU is performing the Function # 998 Diagnostics test, the SCDU displays:



□ ■ Green LED Lit

The PCU will not begin the diagnostic routines if a SEVERE PCU FAULT exists. The PCU will declare a SEVERE FAULT under several conditions including an IST Fault, power supply failure, line sync loss, low line, or DCU failure. If a SEVERE FAULT exists when the PCU starts the diagnostic tests, the SCDU displays:



Green LED Lit

Severe faults can only be cleared by pressing the CPU reset button on the Drive Control PCB or by cycling power to the drive.

If the display stays on 'tEST' and the contactor doesn't pick up, there is a fault in motor field connections or settings.

If all tests indicate that there are no failed power components (SCRs and fuses), the SCDU displays:



Green LED Lit

Press the DATA/FCTN key to exit the PCU Diagnostics routine and return to the "Function" level. The SCDU displays:



Both LEDs Off

If the PCU detects one or more **Open AC Fuses**, it displays the fault code for a blown fuse (**F910**):



Both LEDs Off

If the PCU detects one or more shorted SCR/doubler packs, the SCDU displays the fault code for a shorted doubler (F911):



Both LEDs Off

Remove power from the drive to replace the SCR(s) that are shorted, and repeat this test until the SCDU displays the 'PASS' message.

If the PCU detected one or more open SCR/doubler packs, the SCDU displays the fault code for an open SCR/doubler pack (F912):

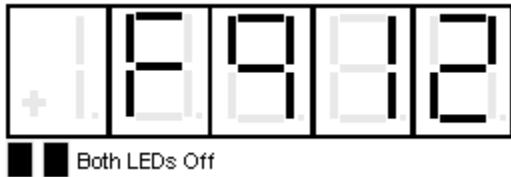

Remove power from the drive, consult Section 5, MAINTENANCE, to replace the SCR(s) that are open, and repeat this test until the SCDU displays the 'PASS' message.

If the PCU detects Reversed Armature Feedback wires, it displays the fault code for a Reverse Armature Fault (F917):

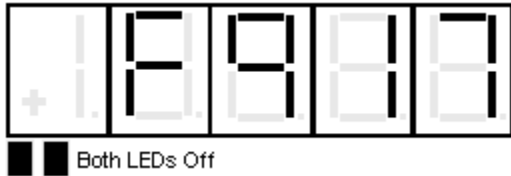

Remove power from the drive, *reverse the Armature Feedback wires*, and repeat this test until the SCDU displays the 'PASS' message. *This fault also occurs if the Armature FB wires are not connected.*

Operating Mode Descriptions

The following feature descriptions explain how each feature works and the necessary or interacting adjustments. Specific adjustments are indicated by function name and/or the function number as (#xx). For more details of any particular adjustment, please refer to the complete numeric listing in this manual.

Motor Field Current Control

Specific adjustments – (#6), (#7), (#8), (#9), (#11), (#17), (#18), (#90)

Related adjustments – (#3), (#10), (#13), (#20)

During normal operation motor field current is held at Stand-by Amps (#17) whenever the drive is idle. When either the Up or Down (Forward or Reverse) logic inputs are energized, the motor field current reference will switch to be Rated Field Current amps (#6). The closed loop current controls will adjust motor field current to achieve that value. When measured field current reaches the magnitude set by Full Field Detect (#90) the motor armature portion of the drive will be internally enabled to start. If motor field current does not reach the magnitude of Full Field Detect (#90) motor armature control will not be enabled. Measured motor field current may be displayed via function (#612).

Field weakening will automatically occur if the encoder speed passes beyond Rated Speed (#3) in Ultra-Lift or other extended speed mode. As speed increases toward the Absolute Maximum RPM (#13), motor field current will automatically follow a calculated profile to hold motor CEMF constant as speed increases beyond Rated Speed. The setting of Weakened Field Current (#9) must be correct at Max Speed (#13) for the motor voltage to be correct.

Motor field current will remain at Rated amps during all other low speed operations, including Load Float and hoist Brake verification testing. If measured motor field current falls below 30% of Stand-by Field Current (#17), a Field Loss fault will be declared (F905).

The motor field regulator needs to know the VAC magnitude of power connected to the SCR-Diode module (#11), the electrical characteristics of the motor field, Rated VDC (#6), Rated amps (#7), L/R (#8), and the desired Response (#18). These values should be correct before attempting to operate the drive. In most cases, leaving the default settings of 0 for (#11) and 5 for (#18) will be adequate. During Self-Tune, the motor field time constant will be measured and displayed at (#615). If Use Self-Tune (#20) is OFF, the L/R value at (#8) will be used to tune the field current regulator. If (#20) is ON the measured value at (#615) will be used.

Motor Armature Current Control

Specific adjustments – (#1), (#2), (#3), (#4), (#5), (#10), (#14), (#21), (#93), (#102)

Related Adjustments – (#19), (#20), (#40)

During normal operation the motor armature current will be proportional to the torque required to satisfy the speed control regulator. When either the Up or Down (Forward or Reverse) logic inputs are energized, and after motor field current has risen beyond the Full Field Detect threshold value set at (#90), the motor armature motor contactor will be commanded to pull-in. Verification of the contactor closure is via an auxiliary feedback contact through TB1(7). Motor armature current will then follow the demands of the velocity regulator. If the Coast-to-Stop mode is selected (#40 = 1) motor armature current will cease and the contactor will open immediately after the Up/Down inputs are released. This will allow the motor to coast to a stop (or to dynamic brake if so equipped). If the selected Start-Stop mode is other than Coast-to-Stop (#40 = 2, or 3), armature current will remain at the value necessary to hold the load at zero speed after the speed regulator has reduced the speed to zero. When Load Float is complete (if enabled) and the Brake has set (if enabled) motor armature current will ramp down to zero at the rate set by Torque Decay Time (#93). When ramp down is complete, and Brake check is complete (if enabled) the motor contactor will be opened.

For proper operation of the armature current regulator, motor nameplate data should be entered at (#1), (#2), (#3), and the drive input voltage at (#10). Enter maximum desired speed at (#13) even if it is the same as (#3). Other important values required for current regulator stability are at (#4), (#5), (#14) and (#21). If Use Self-Tune (#20) is OFF, the L and R values at (#4) and (#5) will be used to tune the armature current regulator. If (#20) is ON the measured values at (#614, L) and (#613, R) will be used. In most cases the default value for armature Current regulator Response (#21) should be used. If the motor contactor fails to close or open as commanded, a Contactor Fault (F402) will be declared. For large horsepower drives that use a slow acting contactor, set (#19) to be ON to allow for a 3 second delay in contactor feedback action.

Motor armature current limit during regeneration (lowering or stopping a hoist load) will be as set by Maximum Armature Current (#14). During motoring (accelerating or lifting a hoist load) the current limit setting will be Maximum Armature Current (#14) divided by Regen Margin (#102). This ensures that the hoist drive can always safely lower, stop or hold back what it can lift. Key motor armature variables may be monitored at (#601), (#608), (#609), (#610), (#611).

Speed Control

Specific adjustments – (#12), (#15), (#16), (#22), (#23), (#24), (#26)

Related Adjustments – (#3), (#13), (#27), (#28), (#30), (#40), (#110)

The speed regulator used in the OMNIPULSE DSD is a Type 2 regulator. It will act to regulate encoder pulse counts (position) and frequency rate (speed), or act to regulate motor armature voltage. During normal operation drive speed will tightly track the commanded speed, including zero, with little or no steady state speed or position error. If Coast-to-Stop or Ramp-to-Stop operating mode is selected (#40 = 1 or 4) the speed regulator will start with a zero armature current command. If either of the other speed control modes are selected (#40 = 2 or 3), the speed error integrator may be pre-set with a specific pre-torque armature current to prevent roll-back as the brake is released, and prevent releasing the brake when pre-torque value is not achieved. Critical adjustments for good speed control, with Rated Speed (#3), Encoder PPR (#12), and Armature Voltage @ Max Speed (#16) properly set to nameplate values, are Bandwidth (#22), Per-Unit Inertia (#23) and Speed Stability (#24). Armature Voltage feedback is set via Parameter #15 = OFF. It is only for applications that operate below base speed of the motor and operate in the speed control modes of Coast-to-Stop, or Ramp-to-Stop. This is selected (#40 = 1 or 4).

Speed Reference Control

Specific adjustments – (#30 - #37), (#27), (#28)

Related Adjustments – (#3), (#13), (#92), (#110 - #113)

Speed Mode Select (#30) determines the source of speed reference commands. The status of logic input commands at TB1(49 Up) and TB1(8 Down) will determine direction, and automatically select Speed Step 1 (#31). When other pre-set speeds are used, they must be selected in sequential order (1 --> 2 --> 3 --> 4 etc.) using external (programmable MFI) logic inputs, or the lowest numbered selection will prevail. Not all speed steps need to be selected, and the actual speed setting values do not need to be in progressive order. The actual speed step settings of (#31 – 37) are a percent of Rated RPM (#3). As different speed steps are selected, the internal reference speed will ramp up or down at the pre-programmed Accel (#27) or Decel (#28) rate.

If Speed Mode Select (#30) is set to 2, the speed reference will be from the analog input at TB1(68-63) and internal speed steps will not be used (except for zero and Jog). The analog input will still be conditioned by accel and decel rate controls. If Speed Mode Select (#30) is set to 3, the largest of either the external analog or internal selected speed step will be used (except for zero and Jog).

If Jog is enabled, Jog speed (#37) will be selected and will override any other selected speed step. If the Inch mode is enabled, the selected speed step will become zero at the end of Inch Time (#92). Micro-Speed and Ultra-Lift settings can also modify the internal speed reference. In all cases, the maximum speed reference will be limited to the Absolute Maximum Speed setting (#13) or the calculated maximum speed when Ultra-Lift is ON. The internal ramped speed reference can be monitored at (#600), with the set target value at (#602).

Micro-Speed Operation

Specific adjustments – (#38), (#39)

Related Adjustments – (#30 - #37)

Micro-Speed may be engaged from an external logic (programmable MFI) input to cause the presently selected speed reference to be multiplied by a fractional value Micro-Speed Gain 1 (#38) or Micro-Speed Gain 2 (#39). This is useful to help position a load more precisely than can be accomplished at a higher speed.

Ultra-Lift Operation

Specific adjustments – (#110), (#111), (#112), (#113), (#114)

Related Adjustments – (#13), (#14)

The Ultra-Lift operating mode allows a crane or hoist to move more quickly when lightly loaded. It does so by weakening the motor field, which allows it to rotate faster without causing or requiring additional motor voltage. Ultra-Lift is selectively enabled or disabled according to the value set in Ultra-Lift Mode (#110). When enabled, and when the reference speed and measured speed are both greater than the Ultra-Lift Threshold Speed (#111), and measured motor armature current (torque) is less than the Ultra-Lift Maximum Current threshold (#113), a maximum safe operating speed will be calculated. The calculation accounts for additional armature current that may be necessary to control the load with weakened field strength and present settings for Current Limit (#14). The calculated speed may be less than but never greater than Ultra-Lift Maximum Speed (#112) or Absolute Maximum Speed (#13). If the qualification conditions continue to exist for Ultra-Lift Check Time (#114), Ultra-Lift will be engaged. The internal reference speed will be switched to the pre-calculated Ultra-Lift speed. As motor speed increases beyond Rated RPM (#3), automatic motor field weakening may take place as previously described. When the selected speed is reduced below the Ultra-Lift Threshold Speed (#111) Ultra-Lift Speed mode will be turned OFF and normal deceleration to a lower speed will begin. As rotational RPM reduces toward Rated RPM (#3), motor field current will gradually increase to again be at Rated Field Amps (#6).

Coast To Stop Operation

Related Adjustments – (#40), (#27)

The default drive Starting and Stopping mode is Coast To Stop. (Function #40 = 1) In this mode, the drive acceleration rate will be controlled by (#27), but when Up and Down logic inputs are removed motor torque will immediately cease. This will allow or cause the motor to coast to a stop. The motor contactor will open as soon as current ramp-down is complete. The drive will then use dynamic braking, if so equipped. Any machine Brake logic output will also be deactivated at this time. This mode is useful for machine operations where no slow-down braking action is required.

If a multi-function input is programmed to be either an External Fault or External Stop function, the activation of that input will cause the drive to perform a Coast To Stop.

Ramp To Stop Operation

Related Adjustments- (#40), (#27), (#28)

Setting Start-Stop Mode control (#40) to a 4 programs the drive for a ramp to stop. In this mode the drive acceleration rate will be controlled by (#27), and the deceleration rate will be controlled by (#28). When Up and Down logic inputs are removed. The drive will decelerate to zero speed. The motor contactor will open as soon as zero speed is reached. Any machine Brake logic output will also be deactivated at this time. This mode is useful for applications that require the motor to be at zero speed prior to setting the brake.

Automatic Brake Control and Load Float Sequencing

Specific adjustments – (#40 – #50), (#91)

Related Adjustments – (#27), (#28), (#71 - #79 Logic Input selects), (#81- #87, Logic Output selects), (#93)

Setting Start-Stop Mode control (#40) to 2 or 3 turns automatic brake control sequencing ON. Mode =2 is Brake sequencing. Mode =3 is for Brake sequencing with Brake switch answer-back.

The drive Start sequence will be:

- 1) A logic Up or Down command input will cause the drive field and armature circuits to start as previously described. However, pre-torque will be activated to start with motor armature current at the last known current, or at other minimum pre-set values (see “Starting Torque” explanation below).
- 2) The Brake output will be energized when 1) is satisfied and it is determined that motor field and motor armature current are indeed at the expected current (Torque Proving) in IFBK OK Time (#50) or Pre-Torque Fault, F413, will be declared.
- 3) When Brake Release Time (#41) expires, and/or Brake Answer-Back is received (if enabled) the internal speed reference will be released to begin ramping toward speed 1 (or other speed if enabled). If Answer-Back is turned ON, the Answer-Back signal must be received before Answer-Back Time (#44) or an Answer-Back fault, F403, will be declared.
- 4) A Brake Release Timer (#47) will be started. During Brake Release Time (#47) seconds, encoder motion will be measured to determine when the load actually moves, as proof that the brake has indeed released. If encoder movement is less than Brake Release Movement (#48) before time (#47) expires, a Brake Release Fault (F410) will be declared and the unit will shut down.
- 5) If all of the above occur in the proper sequence the drive will be accelerated toward the selected speed. If a Brake Hold Fault (F401) exists, speed in the Up direction will be limited to Brake Fault Speed (#49).

The drive Stop sequence will be:

- 1) The Up or Down logic input command is released. The drive will decelerate to zero speed.
- 2) With the speed reference at zero and when zero speed is detected by Threshold (#91), Load Float time (#43) will begin. The drive will continue to hold the load at zero speed.
- 3) When Load Float time (#43) expires, the Brake coil output will be de-energized. Two timers will be started and the drive will continue to hold the load during Brake Set time (#42) and Brake Slip Time (#45). [A third timer, Brake Answer-back check, will also expect that the answer-back contact will be correct within Answer-back Time (#44) seconds, or an F403 fault will be declared.]
- 4) After Brake Set timer (#42) expires, motor armature current (torque) will ramp to zero according to torque Decay Time (#93). Any encoder movement will be recorded during Brake Slip Time (#45). Encoder movement may be displayed at (#620).
- 5) If total encoder movement during Brake Slip Time (#45) is less than Max Brake Slip (#46) the Brake will be considered to be holding the load correctly. The drive will continue to shut down by opening the motor contactor and setting motor field current to Stand-By current (#17).

- 6) If total encoder movement during time Brake Slip Time (#45) exceeds the setting of Max Brake Slip (#46) the Brake will be considered faulty. A Brake Hold Fault (F401) and Alarm will be declared. The Load Float mode will be immediately re-started, with armature current at the torque previously established as that necessary to hold the load. Brake Fault alarm outputs will be energized by F401 if so programmed (factory default). The drive will remain indefinitely in Load Float mode with F401 showing on the display with Brake Fault output alarms energized until a new Up or Down logic input command is received. During the Load Float re-start process, a Brake Release fault (F410) will be blocked from preventing the drive to re-start. The Brake Alarm Fault will remain active until a successful stop has been accomplished.
- 7) If a new Up or Down command is received when a Brake Hold Fault (F401) is active, the drive will terminate Load Float and begin to accelerate, but speed will be limited to Brake Fault-Speed (#49) in the Up direction. When the Up or Down command is release, a new Load Float cycle will be started. A Brake Hold Fault (F401) will be cleared, de-energizing the Brake Alarm output and releasing the restriction of speed in the Up, only if a new Brake Hold test is successful.

One can obtain Controlled Stop operation with or without a mechanical load brake by setting Load Float Time (#43) to zero. Setting Brake Release, Set, Release Test, or Slip Test times (#41), (#42), (#47), or (#45) also to zero, will simply eliminate any operating delay associated with either of those features.

Starting Torque

Specific adjustments – (#100), (#101), (#103)

Related Adjustments – (#14), (#30), (#102)

When Start-Stop Mode (#40) is set to 1, the drive will always start with zero armature current. When Start-Stop Mode (#40) is set to 2 or 3, pre-torque is turned ON. Each time the drive is started the minimum armature current at start-up will be largest of Initial Starting Torque (#100) or Minimum Starting Torque (#101), or the last torque measured when the drive was in Load Float. If armature current does not equal the pre-torque reference a Pre-torque Fault, F413 will be declared. The maximum starting torque in the down direction is limited by, Down Start Current Limit (#103) until the Brake is confirmed to be lifted. Motoring torque is always limited to less than the number defined by Maximum Armature Current (#14) divided by Regen Margin (#102).

During acceleration or deceleration, bumping into either armature current limiting or calculated rated motor CEMF will cause a temporary pause in speed reference ramping. This purposely slows down the rate of acceleration in order to prevent regulator wind-up. Further acceleration will not continue unless the maximum voltage or current conditions are relieved by this action.

Analog Input References

Specific adjustments – (#51), (#52), (#53), (#55), (#57), (#58)

Related Adjustments – (#30), (#104), (#668), (#676)

Two differential analog input channels are available: TB1(68-63) for a speed reference and TB1(76-71) for armature current (torque). The drive hardware will accommodate +/-10V range on both channels. However, the active range may be limited to be uni-polar only by setting Bi-polar Enable selects (#51) or (#55) to zero. Separate Bias and Gain adjustments are provided at (#52), (#53), and (#57), (#58) for each channel. One can read the resulting reference values at (#668) and (#676). Setting the gains of (#53) or (#58) to zero will avoid any signal interference if these inputs are not used.

Torque Follower Regulator

Specific adjustments – (#104)

Related Adjustments – (#55), (#57), (#58)

An analog signal input at terminals TB1(76 – 71) may be used as a torque command. The internal speed reference will be trimmed to yield more (or less) motor armature current as requested by the external signal. This feature is useful for load sharing between two or more units. Conditioning of the external signal is via adjustments Bi-Polar Enable (#55), Bias (57) and Gain (#58). The resulting torque reference may be viewed at (#676). Gain of the torque regulator [the amount of speed trim per torque error] is adjusted at Torque Regulator Gain (#104).

Limit Switch Operations

Specific adjustments – Selections for (#71 – 79)

One or more multi-function inputs may be programmed to work with external Slow or Stop limit switches in either the Up or Down direction.

When either an **Up-Slow** or **Down-Slow** logic input becomes active, the internal selected speed will be that of Speed 1 (#31) for that particular direction. The drive will decelerate to that speed at the Deceleration Time rate set at (#28). The drive will be allowed to move in the opposite direction at any other selected speed.

An active **Down Stop** limit logic input will cause the drive to decelerate to zero speed at the Deceleration Time rate set at (#28). The drive will be allowed to move Up at any other selected speed.

An active **Up Stop** limit logic input condition AND a valid UP command will cause the drive to immediately call for zero speed with an internal Load Float time of zero. There will be no timed ramp-down of speed during the deceleration. The brake will set when the drive comes to a halt if programmed to do so. This will cause the hoist to stop moving Up as fast as possible. The drive torque may hit current limit (#14) during the stopping process.

If a multi-function input is programmed to be either an **External Fault** or **External Stop** function, the activation of that input will cause the drive to perform a Coast To Stop. An **External Fault** event will be latched and will require an External Reset command to be cleared. An **External Stop** command is not latched and will recover as soon as the **External Stop** input command is removed.

Diagnostic Indicators

The following status lights are visible on the front panel of the drive:

READY – Green. Indicates that the drive is ready to run when told to do so.

RUN – Green. Indicates that the drive is in the Run state with motor contactor closed.

TORQUE LIMIT – Yellow. Indicates that current reference is being limited. This light will also blink at 2 Hz if the drive is limiting speed due to excessive motor voltage or CEMF.

OVERLOAD – Yellow. Indicates that drive current reference is in the overload region or that the motor overload has tripped.

E-STOP – Red. Indicates that the E-Stop control line is open such that the contactor cannot be closed.

FAULT – Red. Indicates that a drive Fault condition exists.

Alarm Outputs

Related Adjustments –

Logic Output selects (#81 – #87)

Alarms indicate warnings of important impending malfunction conditions, but will not automatically shut down the drive. Two separate alarm functions may be steered to activate any of the programmable logic output lines. **Alarm-1** is activated by Drive Thermistor/thermostat, Drive Over-Temperature, Motor Thermostat, or Motor Over-Load failure or fault conditions. **Alarm-2** functions are individually selectable and TBD.

Drive Commissioning and Start-up Procedure

It is important to follow common sense procedures to install and commission OMNIPULSE DSD drives. The following sequence should be followed to calibrate and initialize the equipment before attempting to operate on a live crane. Failure to do so may result in safety risks for personnel and/or damage to equipment. The basic procedure steps are:

- 1) If the motor is presently being used with an older controller or m-g set, measure and record the DC volts and amps being supplied to the motor field as it is used with older controllers. Also record typical armature volts and amps as it is being used. This will yield important set-up data that is not likely to be available from the motor nameplate.
- 2) If the motor was previously used with an older controller or m-g set, inspect and service it before attempting to operate it from the OMNIPULSE DSD controller. High-pot the motor field and armature circuits to at least 600 VAC from motor leads to frame for 2 minutes to verify the quality of motor insulation. Inspect and clean the motor commutator. Replace and adjust worn brushes. If there is any question about the integrity of motor insulation, have the motor re-worked.
- 3) Ensure that the speed feedback encoder is mounted to be electrically isolated from the motor shaft and frame. Ensure that the coupling is tight and correctly aligned.
- 4) Verify that motor field wires at TB4 on the drive are connected to the proper ampere range tap. Verify that SW1 on PCB A3 is set to correspond to the ampere range tap being used.
- 5) Turn control power to the drive ON and enter in pertinent motor nameplate and site application data for parameters #1 – 19. SAVE the data to NV-RAM. [See section 3.6]
- 6) Enter in other site set-up data corresponding to multi-function input and output use requirements and necessary set point adjustments. Be sure to enable controlled stop at (#40) if it is expected to stop the drive. Temporarily set Absolute Max RPM (#13) to Rated Motor RPM (#3). SAVE the data to NV-RAM.
- 7) Turn control power OFF. Turn control and mains power ON. Verify that the READY light comes ON after several seconds.
- 8) Use a separate DC clamp-on ammeter to verify that measured DC current to the motor field corresponds to what the drive reports at #612. [Should be at Stand-by amps after power-up.]
- 9) Bypass the E-Stop circuit and perform Self-Diagnostics, F998. Should PASS. [See section 3.9] Block motor armature or disable the mechanical brake so that it will not lift and perform Self-Tune, F997. [See section 3.8. Only a small amount of torque will be produced, but the motor armature should not be permitted to rotate during the test.] Review Self-Tune data at #613, #614, & #615. If the data is reasonable set #20 ON. SAVE the data to NV-RAM. Remove the E-Stop jumper.
- 10) Enable the drive E-Stop circuit and Select UP. Verify that:
 - a) Measured motor field current at #612 goes to Rated Amps;
 - b) The drive contactor does pull in;
 - c) The motor does indeed rotate in the proper direction at pre-set speed 1.
 - d) Resolve any problems before continuing.
- 11) Verify Down direction and other speed selections using a procedure similar to step 10.
- 12) If there is noticeable overshoot or undershoot, adjust speed regulator tuning.
- 13) If equipped with machine Brake, verify and adjust automatic Brake controls.
- 14) If equipped with Ultra-Lift, adjust and verify operation. Set Max RPM (#13) to the desired maximum operating speed or increase in incremental steps to verify proper operation. Read motor armature CEMF (#609) and/or motor armature voltage (#610) at high speed. Adjust Motor Weak Field Current (#9) to yield the same CEMF at all speeds above Rated RPM (#3).

Parameter Function Descriptions

Rated Arm Volts

Function #1

Units: VDC Range: 150. – 550.
Default: 240

This entry sets the motor nameplate full load, full speed voltage required by the motor used with the drive. It should agree with the motor nameplate data.

Rated Arm Amps

Function #2

Units: ADC Range: 2.0 - 1250.0
Default: 26.0

This entry is specified by the motor nameplate amps for the motor used with the drive.

Rated Motor RPM

Function #3

Units: RPM Range: 50.0 – 1999.0
Default: 1750

This entry calibrates motor speed. The motor RPM X Encoder PPR is what will actually be speed regulated. When a speed reference is set at 100%, the motor will rotate at this RPM.

Manual Armature Inductance

Function #4

Units: HNY Range: 0.001 – 1.000
Default: 0.01

This is the value of the motor circuit inductance used to manually tune the armature current regulator. The value to be entered is best measured by monitoring F614 - Measured Motor Circuit Inductance, after the SELF-TUNE function has been completed. This value is used to calculate armature current regulator gains.

Manual Armature Resistance

Function #5

Units: OHM Range: 0.001 – 5.000
Default: 0.1

The total armature circuit resistance. The value to be entered is best measured by monitoring F613, measured circuit resistance after the SELF-TUNE function has been completed. This value is used to calculate armature current regulator gains and to calculate motor CEMF.

Rated Field Current

Function #6

Units: ADC Range: 0.20 – 40.00
Default: 2.00

This is the motor field current amperes the drive should provide when starting and at low speed. It should agree with Rated Motor Field Current according to the motor nameplate.

Rated Field Volts

Function #7

Units: VDC Range: 50 – 525
Default: 240

This is the Rated Field Voltage necessary to produce Full field amps (#6) per the motor nameplate. It is used to calculate motor field circuit resistance and determine motor field current regulator gains. Improper adjustment can affect stability.

Manual Field L/R**Function #8**

Units: SEC Range: 0.10 – 10.00
Default: 0.54

This is the Motor Field time constant, L/R. It is an important value to determine motor field current regulator gains. The value to be entered is best measured by monitoring F615 - Measured Field L/R Time Constant, after the SELF-TUNE function has been completed

Weak Field Current**Function #9**

Units: AMP Range: 0.1 – 40
Default: 30

This entry calibrates motor field weakening and CEMF at high motor speed. Set this value to the motor field amperes required at maximum speed (#13). Read and verify CEMF at (#609) and Armature Volts (#610) at maximum speed. Adjust (#9) accordingly to not exceed motor voltage ratings. Weak field current (#9) may be set larger than Rated Field Current if field weakening is not used as motor field current will never exceed (#6) amperes.

Nom AC Voltage**Function #10**

Units: VAC Range: 150. – 525.
Default: 480

This entry sets the nominal AC line to line voltage applied to the drive from the utility input or secondary of the isolation transformer. This value should agree with the nominal utility value. It sets the Low Line and Excessive CEMF detection thresholds.

Field Source Volts AC**Function #11**

Units: VAC Range 0. – 525.
Default: 0.

This is the single phase AC voltage used to power the Field Rectifier module. The factory default value of zero will let the drive automatically select the same value as supplied for the motor armature circuit as set by (#10). This conforms to factory supplied wiring. If an external transformer is used to supply a different voltage to power the motor field circuit, set this value to the nominal VAC provided.

Encoder Pulses/Rev.**Function #12**

Units: P/R Range: 600. – 19,999.
Default: 1024.

This entry sets the per channel pulses per revolution per the encoder nameplate.

Absolute Max RPM**Function #13**

Units: RPM Range: 50 – 3,000
Default: 1750

This defines the maximum allowable motor RPM. The internal reference speed will be limited to not exceed this number in any operating mode.

Maximum Armature Current**Function #14**

Units: % Range: 0 – 300
Default: 250

This entry defines the maximum motor armature current as a percent of Rated Motor Amps (#2). The current limit during regeneration will be set to this value. Armature current during motoring will be limited as defined at (#102).

Encoder Feedback On**Function #15**

Units: Logic Range: 0 (Off) – 1 (On)
Default: 0 (OFF)

This entry selects the source of speed feedback. When this Parameter is programmed to 1 (On) the speed regulator will use the motor encoder pulses to regulate motor speed. When programmed to 0 (Off) the OMNIPULSE DSD speed regulator will use armature voltage feedback to regulate speed. Armature Voltage feedback is only for applications that operate below base speed of the motor. It will operate only in the start stop modes of Coast-to-Stop, or Ramp-to-Stop.

Armature Voltage @ Max Speed**Function #16**

Units: VDC Range: 150 – 550
Default: 500

This entry is used to calibrate the drives speed regulator when controlling the OMNIPULSE DSD in Armature Voltage feedback mode.

Standby Field Current**Function #17**

Units: % Range: 10 - 100
Default: 25

This is the field current in percent of (#6) amperes that the drive should provide when the system is at rest (i.e. stopped with no Run command).

Field Regulator Response**Function #18**

Units: RAD Range: 1.0 – 10.0
Default: 5.0

This input defines the desired motor field current regulator bandwidth in radians per second.

3 Second Motor Contactor Fault**Function #19**

Units: Logic Range: 0 (Off) – 1 (On)
Default: 0 (Off)

This Parameter selects the detection time for motor contactor faults. These occur when the contactor acknowledge feedback contact fails to open or close according to the commanded state of the contactor coil driver. Small contactors should operate within 450 milliseconds and should use the default value, 0, or OFF. If large contactors are used with large hp drives, set this value to ON to yield a 3 second fault detection time.

Use Self Tune**Function #20**

Units: Logic Range: 0 (Off) – 1 (On)
Default: 0 (OFF)

This entry selects the source of critical numeric value adjustments for tuning the motor armature current regulator. Values for motor resistance, R, motor inductance, L, and motor field time constant L/R may come from either manually entered values or automatically determined by a self-tune measurement. With (#20) set to 0, OFF, the settings of (#4), (#5), and (#8) will be used. With (#20) set to 1, ON, the values determined by self-tuning and held at display locations (#613), (#614), and (#615) will be automatically used.

Note: Setting this Parameter to a 1 will *not change the values stored in (#4), (#5), or (#8).*

Arm Current Resp.**Function #21**

Units: RAD Range: 100. – 750.
Default: 250.

This entry sets the band width of the current regulator in radians. The nominal setting for this entry for most cases would be 250 radians. The responsiveness of the armature current regulator will increase as this number increases. If this number is too large, the motor current may fluctuate. If this number is too small, the motor response may become sluggish.

Speed Reg Resp.**Function #22**

Units: RAD Range: 1.0 – 10.0
Default: 4.0

This entry sets the closed loop bandwidth response of the speed regulator. ***Increasing the value of Parameter #22 will make the drive more responsive, but may also cause unwanted amplification of mechanical vibration.***

Sys PU Inertia**Function #23**

Units: SEC Range: 0.25 – 15.00
Default: 2.00

This value is the ratio of the effective inertia of the moving equipment mass to the rated torque strength of the motor. The units, seconds, would be the time it would take to accelerate the system inertia to rated speed using rated motor amps. This value affects the feed-forward gain of the speed regulator and affects how well it will follow a changing reference speed and variations in load.

Speed Stability**Function #24**

Units: — Range: 1.0 – 10.0
Default: 2.0

This setting affects the proportional gain and Phase Margin of the regulator. Decreasing this setting will make the regulator more responsive to correct mechanical load speed variances, but can cause it to amplify unwanted mechanical disturbances. Increasing the setting value will provide smoother operation but at the expense of time-delayed reaction to speed errors.

Position Damping**Function #26**

Units: - Range: 0.5 – 10.00
Default: 2.00

This value adjusts damping of the second integrator that helps regulate position during Load Float.

Acceleration Time**Function #27**

Units: SEC Range: 0.5 – 15.0
Default: 5.00

Total acceleration time in seconds for a change in speed from zero to Rated Speed (#3). All changes to an increase in speed will be limited to this rate of change setting.

Deceleration Time**Function #28**

Units: SEC Range: 0.5 – 15.0
Default: 3.00

Total deceleration time in seconds for a change in speed from Rated Speed (#3) to zero. All changes to a decrease in speed will be limited to this rate of change setting.

Analog Source Select

Function #29

Units: Number Range: 0 - 1
Default: 0

This Parameter allows the user to select the source of the analog reference signals.

Setting this value to 0 (default) enables the analog speed and torque command to follow the corresponding analog input references.

Setting this value to 1 enables the analog speed and torque command to follow the corresponding Modbus register references.

Speed Mode Select

Function #30

Units: Number Range: 1 - 3
Default: 1

This Parameter allows the user to select the source of the speed reference signal.

• Multi-Step

Setting this value to 1 (default) enables the drive to follow only digital Pre-set Speeds defined via Parameters #31 – #36 as selected by logic input commands. The direction of travel will be supplied by the Up/Down logic input commands.

• Analog Only

Setting this value to 2 enables the drive to follow only the magnitude of the external **analog** reference. The direction of travel will be supplied by the Up/Down logic input commands. A logic command to Jog will temporarily override the analog reference selection.

• Higher Reference

Setting this value to 3 enables the drive to follow the either the selected pre-set speed value or the analog reference input value, whichever is greater. A logic command to Jog will temporarily override either the analog or pre-set speed reference selection.

Preset Speeds

Functions #31 - 37

Units: % [of Rated RPM (#3)]

Range:

#31, speed 1: 0 – 50, Default: 10

#32, speed 2: 0 – 150, Default: 20

#33, speed 3: 0 – 150, Default: 30

#34, speed 4: 0 – 150, Default: 40

#35, speed 5: 0 – 150, Default: 50

#36, speed 6: 0 – 150, Default: 60

#37, Jog speed: 0 – 10, Default: 5

Seven digital pre-set speed settings are available. Pre-set speed 1 (#31) is automatically selected when an Up or Down input command is active. Pre-set speeds 2 – 6 (#32-#36) are selected in a progressive manner with the activation of additional logic input commands. Not all of the pre-set speeds need to be used, but if selected out of sequence the lowest numbered speed in sequence will be engaged. An external analog speed command or Ultra-Lift mode may override any pre-set speed, when enabled. Pre-set speed #37 is used for Jog. Selecting Jog will override any other speed selection.

Micro-Speed 1 Gain

Function #38

Units: PU Range: 0.00 – 1.00

Default: 1.00

Micro-Speed may be used to operate the drive at a slow speed for accurate load positioning. When Micro-Speed 1 is activated by an external logic command, the internal speed reference will be multiplied by this value.

Micro-Speed 2 Gain

Function #39

Units: PU Range: 0.00 – 1.00

Default: 1.00

Micro-Speed may be used to operate the drive at a slow speed for accurate load positioning. When Micro-Speed 2 is activated by an external logic command, the internal speed reference will be multiplied by this value. Micro-Speed 2 will take priority over Micro-Speed 1.

Start-Stop Mode

Function #40

Units: Numeric selection Range: 1 – 4

Default: 1

This Parameter selects the operating mode for starting and stopping.

• Coast to Stop

Setting this value to 1 causes the drive to have controlled acceleration via (#27), but motor torque will immediately cease when Up and Down logic inputs are disabled, allowing the motor to coast to a stop. This mode is useful for machine operations where no slow-down braking action is required. An external Brake may be controlled in this mode if programmed to a logic output. Brake timing Parameters (#41), (#42), (#43) (#44), (#47) and (#48) are still active.

• NLB Hoist

Setting this value to 2 will activate a controlled stop mode of operation for no load brake hoists, with or without coordinated brake control, as other variables are programmed. Acceleration will be controlled on a start via (#27), after external brake release and confirmation according to settings for (#41), (#47), and (#48). When Up and Down logic input commands are released, the drive will decelerate to zero speed at the rate established by (#28). When zero speed is achieved according to (#91), the control will go into Load Float for time (#43). At the end of Load Float time the Brake control output will be de-energized (if used) and the brake will be checked according to settings of (#42), (#45) and (#46). When Brake Slip check time (#45) is successfully completed, the motor armature motor contactor will be de-energized.

If no Brake action is required, set (#41), (#42), (#43), (#45), and (#47) to zero.

• NLB Hoist with Answer Back

Setting this value to 3 will activate a controlled stop mode of operation as described above for no load brake hoists, with coordinated brake control, AND the use of an answer-back contact on the Brake. The correct answer-back response must be received by time (#44) when the brake is energized or de-energized.

• Ramp to Stop

Setting this value to 4 causes the drive to have controlled acceleration via (#27), and the deceleration rate will be controlled by (#28). When Up and Down logic inputs are removed, the drive will decelerate to zero speed. The motor contactor will open as soon as zero speed is reached. Any machine brake logic output will also be deactivated at this time. This mode is useful for applications that require the motor to be at zero speed prior to setting the brake.

Brake Release Timer**Function #41**

Units: SEC Range: 0.0 – 2.55 Seconds
Default: 0.7

Allows time for the Brake to physically release before allowing the internal speed reference to move away from zero on a drive start. This reduces wear on brake pads during a start.

Brake Set Timer**Function #42**

Units: SEC Range: 0.0 – 2.55 Seconds
Default: 0.7

Allows time for the drive to continue to hold the load while the brake is being de-energized and set.

Load Float Time**Function #43**

Units: SEC Range 0 – 255 Seconds
Default: 10

Programs the Load Float time. Load Float, where the drive holds the load at zero speed with brake released, will start after the drive decelerates to zero speed according to the setting of (#91). Re-energizing either the Up or Down logic command while in Load Float will cause the drive to move the load and reset the Load Float timer. Load Float will NOT occur if (#40) is set to 1.

Answer-Back Time**Function #44**

Units: SEC Range 0.0 – 2.55 Seconds
Default: 0.7

Programs the maximum time allowed for the Brake Answer-back contact to confirm that the Brake has indeed released or set as directed by the Brake actuation output. If the answer-back contact does not agree with the status of the Brake control output for longer than (#44) seconds, a Brake Answer-Back Fault, F403, will be declared. [Exception- Brake Answer-back will be ignored in the event of a Brake Hold Fault, F401.]

Brake Slip Timer**Function #45**

Units: SEC Range 0.0 – 25.5 Seconds
Default: 5.0

Programs the time that brake slip will be checked after the brake has been told to set. This timer is independent of and will run concurrently with Brake Set Time (#42). The Brake Slip timer is de-activated in the Coast to Stop mode, (#40) set to 1.

Maximum Brake Slip**Function #46**

Units: encoder counts Range 0 – 16536
Default: 250

Programs the limit of brake slippage allowed during time (#45). If the measured accumulation of encoder movement during time (#45) exceeds the setting of (#46), a Brake Hold Fault, F401 will be declared. Load Float will then be turned back ON and held until a run Up or Down logic input is received.

Brake Release Check Time**Function #47**

Units: SEC Range 0 – 2.55 Seconds
Default: 0.5

Time that the encoder counts will be monitored to determine when the brake actually releases. Status of the brake will be determined to be released after Brake Release Time (#41) has expired AND if/when accumulated encoder movement exceeds (#48) counts. If the accumulated encoder movement is less than (#48) counts at the end of (#47) seconds, a Brake Release Fault, F410, will be declared. If brake answer-back is turned ON [(#40) set to 3] the Brake Release Check Timer will not start until brake answer-back has also occurred.

Brake Release Movement**Function #48**

Units: encoder counts Range 0 – 16536
Default: 50

Programs the net movement, in encoder counts, to accumulate to determine when the brake actually releases. Status of the brake will be determined to be released after Brake Release Time (#41) has expired AND if/when accumulated encoder movement exceeds (#48) counts. If the accumulated encoder movement is less than (#48) counts at the end of (#47) seconds, a Brake Release Fault, F410, will be declared.

Brake Fault Speed**Function #49**

Units: % Range: 0 – 150
Default: 10.0

If a Brake Hold Fault (F401) occurs, the reference speed in the Up direction will be limited to this value until the fault is reset.

IFBK OK Timer**Function #50**

Units: SEC Range 0.00 – 2.55 Seconds
Default: 1.5

Sets the amount of time to look for the Armature Current to be OK before posting a Pre-torque Fault, F413. Enabled when Start-Stop Mode, F40 = 2 or 3 only. Setting this Parameter to 0.00 will disable torque proving at start.

Bipolar Anlg Input T68**Function # 51**

Units: Logic Range: 0 (OFF) – 1 (ON)
Default: 0 (OFF)

This enables or disables a bi-polar (+/-10V) analog input signal at terminals TB1(68-63) to be used as an external analog speed reference.

If set to 0 (OFF), the external signal will be truncated to have an effective value between 0 and +10V, AFTER the bias (#52) is added

If set to 1 (ON), the effective value will retain the polarity sign of the +/-10V input signal AFTER the bias (#52) is added. This allows a bi-polar signal to control direction as well as speed.

Analog In T68 Bias**Function # 52**

Units: PU Range: +/-2.00
Default: 0.0

This entry is an offset bias to apply to the external analog signal from TB1(68-63).

Analog In T68 Gain**Function # 53**

Units: PU Range: 0 – 2.00
 Default: 1.0

This entry is a multiplier gain to apply to the analog signal from TB1(68-63) AFTER the offset bias (#52). The resulting signal may be viewed at (#668). The resulting value may be used as a per unit speed command from an external analog signal if enabled at (#30).

Bipolar Anlg Input T76**Function # 55**

Units: Logic Range: 0 (OFF) – 1 (ON)
 Default: 0 (OFF)

This enables or disables a bi-polar (+/-10V) analog input signal at terminals TB1(76-71) to be used as an external analog torque reference.

If set to 0 (OFF), the external signal will be truncated to have an effective value between 0 and +10V, AFTER the bias (#57) is added

If set to 1 (ON), the effective value will retain the polarity sign of the +/-10V input signal AFTER the bias (#57) is added. This allows a bi-polar signal to control dictated torque direction as well as magnitude.

Analog In T76 Bias**Function # 57**

Units: PU Range: +/-2.00
 Default: 0.0

This entry is an offset bias to apply to the external analog signal from TB1(76-71).

Analog In T76 Gain**Function # 58**

Units: % Range: 0 – 2.00
 Default: 1.0

This entry is a multiplier gain to apply to the analog signal from TB1(76-71) AFTER the offset bias (#57). The resulting signal may be viewed at (#676). The resulting value may be used as a per unit torque command from an external analog signal.

Analog Output 45 Function**Function #60**

Units: Numeric selection Range: 0 – 6
 Default: 1 (Raw Speed Command)

This entry steers a specific internal signal toward the analog output at TB1(45). Selections are:

- 0 = Trace Buffer 0
- 1 = Raw Speed Command
- 2 = Ramped Speed command
- 3 = Encoder Feedback
- 4 = Armature Current Reference
- 5 = Measured Armature Current
- 6 = Measured Armature Voltage
- 7 = Field current Reference
- 8 = Measured Field Current

Analog Out 45 Bias**Function # 61**

Units: PU Range: +/-1.00
 Default: 0.0

This entry is an offset bias to apply to the analog output signal selected by (#60) to be at TB1(45).

Analog Out 45 Gain**Function # 62**

Units: PU Range: 0.0 – 10.0
 Default: 0.80

This entry sets the specific multiplier value for the selected analog output signal to TB1(45) AFTER offset (#62). The output channel is restricted between +/-10V. A value of 0.8 will set 8.0 volts of output for a 1 per unit signal, with some headroom to show over-scale conditions.

Analog Output 46 Function**Function #65**

Units: Numeric selection Range: 0 – 6
 Default: 3 (Encoder Feedback)

This entry steers a specific internal signal toward the analog output at TB1(46). Selections are:

- 0 = Trace Buffer 1
- 1 = Raw Speed Command
- 2 = Ramped Speed command
- 3 = Encoder Feedback
- 4 = Armature Current Reference
- 5 = Measured Armature Current
- 6 = Measured Armature Voltage
- 7 = Field current Reference
- 8 = Measured Field Current

Analog Out 46 Bias**Function # 66**

Units: PU Range: +/-1.00
 Default: 0.0

This entry is an offset bias to apply to the analog output signal selected by (#65) to be at TB1(46).

Analog Out 46 Gain**Function # 67**

Units: PU Range: 0.0 – 10.0
 Default: 0.80

This entry sets the specific multiplier value for the selected analog output signal to TB1(46) AFTER offset (#66). The output channel is restricted between +/-10V. A value of 0.8 will set 8.0 volts of output for a 1 per unit signal, with some headroom to show over-scale conditions.

Multi-Function Input Selects**Functions #71 - 79**

Units: Numeric Logic Selection
 Range: 0 - 25

These entries program individual logic input terminals on TB1 to perform particular logical input control functions. The label/name of the variable as displayed on the PCPU indicates the actual screw terminal marking on TB1. The correlation of parameter number to TB1 input terminal is as follows:

- #71 – TB1(9), default = 1
- #72 – TB1(10) default = 2
- #73 – TB1(11) default = 3
- #74 – TB1(12) default = 4
- #75 – TB1(50) default = 5
- #76 – TB1(51) default = 21
- #77 – TB1(52) default = 0
- #78 – TB1(53) default = 0
- #79 – TB1(54) default = 14

Any MFI logic terminal may be mapped to provide an input function as listed below. CAUTION - More than one terminal may be mapped to the same function. If so, they will operate as if logical OR'ed together. The logic selections are:

- 0 = None, Not Used
- 1 = Pre-Set Speed 2 Select
- 2 = Pre-Set Speed 3 Select
- 3 = Pre-Set Speed 4 Select
- 4 = Pre-Set Speed 5 Select
- 5 = Pre-Set Speed 6 Select
- 6 = Up Slow Limit Sw N/O
- 7 = Up Stop Limit Sw N/O
- 8 = Dn Slow Limit Sw N/O
- 9 = Dn Stop Limit Sw N/O
- 10 = Up Slow Limit Sw N/C
- 11 = Up Stop Limit Sw N/C
- 12 = Dn Slow Limit Sw N/C
- 13 = Dn Stop Limit Sw N/C
- 14 = Micro-Speed #1 Enable
- 15 = Micro-Speed #2 Enable
- 16 = Ultra-Lift Enable
- 17 = External Fault N/O
- 18 = External Fault N/C
- 19 = External Stop N/O
- 20 = External Stop N/C
- 21 = Fault Reset N/O
- 22 = Fault Reset N/C
- 23 = Brake answer-Back Sw
- 24 = Jog Enable
- 25 = Inch Enable

Multi-Function Output Selects

Functions #81 - 87

Units: Numeric Logic Selection Range: 1 – 14

Defaults: See listing below

These entries program individual logic output terminals on TB1 to perform particular output control and status indicator functions. The Kxx label/name of the variable as displayed on the PCDDU indicates the relay reference shown on the connection diagram. Any logic output terminal may be mapped to provide any function as listed below. More than one terminal may be mapped to the same function. The logic selections are:

- 1 = Brake Hold Fault
- 2 = Brake Release Control
- 3 = Drive READY
- 4 = Drive is RUNNING
- 5 = Drive in Torque Limit
- 6 = Moving Up/Fwd
- 7 = Moving Down/Rev
- 8 = At Zero Speed
- 9 = Ultra-Lift engaged
- 10 = Up Limit (Slow or Stop)
- 11 = Down Limit (Slow or Stop)
- 12 = Up or Down Limit
- 13 = Alarm-1 [Thermistor Fail, Over-Temp, Motor Thst, Motor Over-Load]
- 14 = Drive FAULT

Factory default settings are as shown below:

Param #	Relay, TB1(term)	Data, Function
#81	K1, (40-42)	14, Drive Fault
#82	K2, (38-39)	2, Brake Output
#83	K3, (36-37)	2, Brake Output
#84	K4, (78)	12, Up or Dn Limit
#85	K5, (79)	13, Alarm-1
#86	K6, (83)	4, Drive Running
#87	K7, (84)	1, Brake Hold Fault

Full Field Detect

Function #90

Units: % Range: 50. – 95.

Default: 90.

Determines the threshold of sensing when motor field current has risen close to Rated amps to ensure that the drive can produce required load torque. The motor field must be above (#90) percent of (#6) amps for internal logic to recognize that the motor field current is nearly up to the full field value. Motor field current must be above this value before the drive will be allowed to start. The drive will wait for motor field to rise above this value before energizing the motor contactor.

Zero Speed threshold

Function #91

Units: % Range: 0.01 – 5.00 [of Rated speed (#3)]

Default: 0.1

Defines the zero speed threshold for detection of motion via encoder measurement. It controls the Moving-Up/Down, & Zero Speed detector output signals, and determines when Load Float will start. If set too close to zero, minor variations may prevent the speed from being detected as zero, even though the load is observed as being held stationary. If set too far from zero, the brake may set while the unit is still in motion.

Inch Timer

Units: SEC Range: 0.0 – 15.0
Default: 2.0

Function #92

Defines the drive running time when Inching is enabled via a selectable logic input. When Inching is enabled, the drive will automatically stop at the end of time (#92) according to the Start-Stop mode set by (#40). The Up or Down logic input command must be removed and re-applied to begin another inching cycle. Inching may be engaged with any selectable speed command.

Torque Decay Time

Units: SEC Range: 0.01 – 2.50
Default: 0.20

Function #93

This value controls the rate of decay of motor armature current during normal stops. This helps to prevent brake ‘thumping’ or slipping when the drive is shut down and the brake is required to hold the load. Armature current ramp-down will begin after the Run Up or Down command is removed from the drive, and after the brake is supposedly set. Under all normal stopping conditions, the motor armature contactor will be told to open AFTER current ramp-down is complete to reduce wear on contactor contacts. With (#40) = 1, for Coast to Stop, current ramp-down will begin whenever the Up or Down logic command is released. In Brake Control modes (#40) set to 2 or 3 current ramp-down will begin at the end of Load Float time (#43), and after the brake has been de-energized and supposedly set by time-out of (#42). In Ramp to Stop, current ramp down will begin will begin at the end of the deceleration ramp time (#29).

NOTE: The 115 VAC E-Stop circuit must remain closed until after the contactor actually opens for this feature to work properly.

Over-Speed Trip

Units: % [of maximum speed (#13)] Range: 0.0 – 150.0
Default: 110.0

Function #94

This entry sets the positive and negative over speed trip point of the motor used on the drive. If the motor speed exceeds this value, the drive will fault. This value is entered as a percent of rated motor speed (RPM).

Encoder Sense V

Units: % Range: 0.0 – 100.0
Default: 25.0

Function #95

This entry sets the armature voltage threshold where the encoder loss and reverse encoder fault routines activate. This parameter prevents nuisance encoder faults at low speeds and high torque loads. For example, if the rated motor armature voltage is 500 VDC and this input is set at 10%, the encoder loss function will become operative only when the armature voltage is above 50 VDC. This numeric input adjusts the encoder loss sensing function ability to ignore motor IR drop.

Encoder Sense %

Units: % Range: 0.0 – 100.0
Default: 5.0

Function #96

This entry sets the percentage of encoder feedback below which an encoder loss will be declared. But this alone will not result in an encoder loss fault being declared. An encoder loss will be declared when the per unit armature voltage is above the level that is Rated Volts (#1) time the sum of Encoder Sense V (#95) and Encoder Sense % (#96), AND the percent encoder feedback is less than the value entered for Encoder Sense (#96). For example, for default values of 25% (#95) and 5% (#96) < an Encoder Loss will be declared when motor voltage is above 30% (25+5) and the encoder speed feedback indicates less than 5% speed.

Motor Over-Load Current

Units: PU [of Rated Current (#2)]
Default: 1.15

Function #98

Range: 0.50 – 2.00

This value sets the threshold level where the motor overload fault will begin to operate. Sustained motor current above this value will eventually cause an overload trip according to the time set in (#99). Motor current above this threshold value will also cause the Overload indicator light to be ON. See (#99).

NOTE: An Over-Load trip in this version of software is an ALARM. It does NOT cause the drive to automatically stop.

Motor Over-load Time

Units: SEC Range: 2.0 – 500.0
Default: 48.0

Function #99

This value shapes the motor overload time-out curve. Motor armature current is sensed and mathematically integrated over time to detect potential over heating caused by a dragging brake shoe or other repeated abuse beyond ratings of the equipment. The calculation formula used for the electronic motor overload is: $t = T/2(i - Ko)$

Where:

t = Calculated time to trip in seconds

i = Measured Per Unit motor current. Drive Param (#2) defines motor Per Unit current in amperes.

T = Time to trip setting (Param #99) at motor current of (Ko+0.5) per unit current.

Ko = Maximum Per Unit current that will not cause an Overload Trip (Param #98)

The USA National Electric Code (NEC) requires that the overload be adjusted to detect overheating of the motor and motor wiring by using rated motor current as the comparison base. This is not the same as rated current capability of the drive. The NEC requirement is that the overload must trip at 1.15 pu current (no time specified), and after 60 seconds at 1.5 pu current, and after 10 seconds at 2 pu current. It is recommended that the default values of Ko=1.1 and T=50 be used. This will provide no tripping with average motor current of 1.1 pu or less, and a tripping time of 62 seconds at 1.5 pu. See the timing graph below.

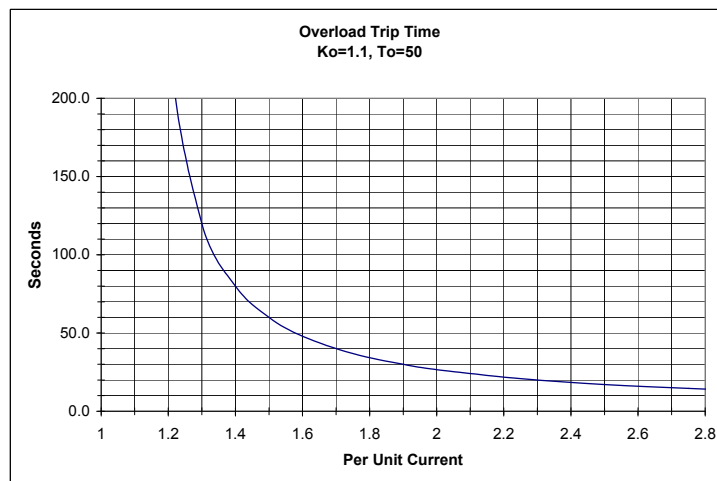

Figure 12: MOTOR OVERLOAD, Ko=1.1, T=50

Initial Starting Torque

Units: % [of Rated Current (#2)]
Default: 100

Function #100

Range: 0 – 100

This entry sets the pre-torque armature current value in Start-Stop Mode (#40) 2 or 3 if no other pre-torque value has been retained in memory from the last stop. The effective minimum value will be set by (#101). During normal stopping in (#40) mode 2 or 3 is to save the motor armature current required to hold the load at the end of Load Float. This value is used to pre-torque the speed regulator integrator when re-starting. If power is turned OFF or the drive is RESET, the pre-torque information is lost. The values of (#100) or (#101) will then be used on the first drive re-start.

Minimum Starting Torque

Units: % [of Rated Current (#2)]
Default: 10

Function #101

Range: 0 – 100

This entry sets a minimum value for initial starting torque (#100).

Regen Margin Function #102

Units: PU Range: 1.0 – 2.0
Default: 1.2

This parameter is the ratio of regen/motoring current limit settings. A ratio greater than 1 guarantees that the torque available during regeneration will be larger than that for motoring.

Down Start Current Limit

Units: % Range: 0 – 100
Default: 10

Function #103

This entry restricts the initial current limit in the down direction before the brake has proven to be released. This prevents the drive from forcing through the brake in the down direction if the brake is indeed holding a heavy load.

Torque Regulator Gain

Units: PU Range: -10 to +10
Default: 0

Function #104

This entry sets the amount of speed reference trim created when using the torque regulator mode. Per Unit speed trim will be $(\text{TorqueRef} - \text{armCurrentRef}) \times (\#104)$. The maximum trim allowed will always be internally limited to +/-10% of Rated Speed (#3).

Ultra-Lift Mode Function #110

Units: Numeric selection Range: 0 – 2
Default: 0 (OFF)

Defines if and how Ultra-Lift will be enabled.

If set to 0, Ultra-Lift is not enabled

If set to 1, Ultra-Lift will be automatically enabled each time speed and load conditions permit.

If set to 2, Ultra-Lift will be enabled when operating conditions permit AND an external logic command is given. Removal of the external Ultra-Lift Enable logic signal will terminate Ultra-Lift, causing the drive to decelerate to the previously established speed.

Ultra-Lift Threshold Speed

Units: % [of Rated Speed (#3)]
Range: 20 – 150 Default: 100

Function #111

Ultra-Lift may be enabled when both the internal ramped reference speed and measured encoder speed are above this set-point.

Ultra-Lift Maximum Speed**Function #112**

Units: % [of Rated Speed (#3)]

Range: 20 – 150

Default: 100

This entry defines the maximum Ultra-Lift speed as a percent of Rated speed (#3). The actual Ultra-Lift target speed will be calculated based on the measured load and field motor weakening that may be necessary. This value represents an upper limit for those calculations.

Ultra-Lift Maximum Current**Function #113**

Units: % [of Rated current (#2)]

Range: 50 – 100

Default: 50

This entry sets the upper limit of load current to allow Ultra-Lift to be enabled. If average load current is above this value during time (#114) Ultra-Lift will not be enabled.

Ultra-Lift Check Time**Function #114**

Units: SEC Range: 0.0 – 30

Default: 2.0

This entry is the dwell time necessary to verify steady state load torque and calculate the maximum Ultra-Lift speed that could be accommodated by weakening the motor field and not cause motor armature current to rise above Rated Current (#2). Time (#114) begins when all other Ultra-Lift enabling conditions are met. If all enabling conditions continue to be met during time (#114), the internal speed reference will be set at the calculated Ultra-Lift speed, but not more than (#112).

Protocol**Function #120**

Units: Logic Range: 0 (Off) – 1 (On)

Default: 2.0

This entry enables or disables the Modbus communication options of drives with firmware versions 409 build 10 and later. When disabled, port J2 communicates via a handheld keypad protocol. When enabled, port J2 communicates via Modbus RTU.

Modbus Baud**Function #121**

Units: NUM Range: 0 – 2

Default: 1

This entry sets the drive's port J2 baud rate when function #120 is On.

If set to 0, the baud rate is 4800 bps.

If set to 1, the baud rate is 9600 bps.

If set to 2, the baud rate is 19200 bps.

Modbus Address**Function #122**

Units: NUM Range: 1 – 31

Default: 1

This entry sets the drive's Modbus slave address when function #120 is set to 1.

Modbus Parity**Function #123**

Units: NUM Range: 0 – 1

Default: 0

This entry sets the drive's Modbus communication parity on port J2.

If set to 0, the parity is None.

If set to 1, the parity is Even.

Modbus Run Time-out**Function #124**

Units: SEC Range: 0.0 – 30
Default: 2.0

This entry sets the time duration the drive will energize the motor without receiving a supported Modbus communication packet while the Forward or Reverse Modbus control register bits are set. A 414 fault will be set when these conditions are met.

Error List Reset**Function # 199**

Units:Logic Range: 0 (Off) – 1 (On)
Default: 0

This entry resets the F#800 error list, removing all faults and errors on the list. This may be used to clear out old data to begin capturing a fresh record.

MONITOR PARAMETER DESCRIPTIONS

Ramped Sped Ref

Units: PU

Function # 600

This display is the ramped per unit speed reference AFTER accel-decel and limit controls.

Motor RPM

Units: RPM

Function # 601

This display is the measured motor RPM.

Speed Reference

Units:PU

Function # 602

This display is the raw speed reference before any limiting or accel-decel conditioning.

Armature Current Reference

Units: PU

Function # 608

This is the Per Unit armature current reference.

CEMF

Units: Volts DC

Function # 609

This display is the CEMF of the motor calculated from measured motor voltage, current and armature circuit resistance.

Motor Armature V

Units: Volts DC

Function # 610

This display is the measured voltage output to the motor armature circuit.

Motor Arm Current

Units: Amps DC

Function # 611

This display is the measured drive output to the motor armature circuit.

Motor Field Current

Units: Amps DC

Function # 612

This display is the measured motor field current.

Measured Motor Resistance

Units: OHMS

Function # 613

This is the measured motor armature circuit resistance calculated during self-tune.

Measured Motor Inductance **Function # 614**
Units: HENRIES

This is the measured motor armature circuit inductance calculated during self-tune.

Measured Field L/R Time Constant **Function # 615**
Units: Seconds

This is the motor field time-constant measured during self tune.

Speed Error **Function # 616**
Units: % of Rated Speed

This displays the difference between the speed reference and speed feedback.

AC Line Frequency **Function # 617**
Units: Hz

This display is the measured frequency of the 3 phase AC line.

Heatsink Temp **Function # 618**
Units: C°

This display is the measured heatsink temperature of the drive in C°.

AC Line Voltage **Function # 619**
Units: Volts rms Line-Line

This display is the measured 3 phase AC input line-line voltage.

Brake Slip **Function # 620**
Units: Encoder counts

This display is the net encoder movement counts accumulated during the brake slip test. It is a live display during time (#45) testing. The total count accumulated during the last test will be held until a new Up or Down command is given.

Analog Speed Command **Function # 668**
Units: %

This is the analog speed command applied to terminal # 68

Analog Torque Command **Function # 676**
Units: PU

This is the analog torque command applied to terminal # 76

FUNCTION #	DESCRIPTION	REFERENCE PAGES
000	VIEW FAULT LIST	Page 48
199	CLEAR ERRORS LIST	Page 79
800	VIEW ERROR LIST	Page 49
801	FAULT/ERROR ACTIONS	See Error Reporting on page 46
980	TRACE MONITOR	-
981	VERIFY I/O	Page 96
993	CLEAR NVRAM	-
994	SAVE/RECALL FUNCTION	See Non-Volatile RAM Access on page 50
995	LOAD DEFAULTS	See Non-Volatile RAM Access on page 51
996	HEX MONITOR	-
997	SELF TUNE	See Self Tune Function on page 52
998	PCU DIAGNOSTICS	See Power Conversion Diagnostics on page 54
999	DCU DIAGNOSTICS	-

Diagnostic Function Descriptions

Software Identification Function # 688-699

The following read-only values identify the drive hardware set up and control software stored in E-PROMs U13, U14, U39 & U40

FUNCTION #	DESCRIPTION	VALUE
688	CUBE I.D.	SEE TABLE 688
689	FIELD RANGE	SEE TABLE 689
690	U13/U14 "97SAXXX"	404
691	PCU RELEASE	-
692	DAY	-
693	MONTH	-
695	YEAR	-
696	BETA "P"	-
697	VERSION "SA"	409
698	RELEASE No.	-
699	CUSTOMER ID	-

Function #688 CUBE I.D. CROSS-REFERENCE

CUBE I.D. No.	Nameplate Amps	Max RUN amps	Max Input VAC
1	9	10	525
6	28.6	31	525
9	61.6	62	525
12	111	106	525
15	209	206	525
21	348	330	525
28	513	480	525
31	679	640	525
37	1025	1100	525
43	1330	1550	525
44	111	106	600
46	348	330	600
47	513	480	600
48	679	640	600
49	1025	1100	600
50	1330	1550	600

Nameplate Amps is DC amps shown on drive nameplate. Maximum RUN amps is rated at 200% overcurrent.

Function #689 FIELD CURRENT RANGE

#689 SW1 Read-Back*	Minimum Rated Field Amps DC	Maximum Rated Field Amps DC
1	0.2	1.9
3	7.0	16.0
6	2.0	6.9
8	16.1	40.0

*Indicates actual SW1 setting

Modbus RTU Communications

OmniPulse DSD drives with firmware versions 409 build 10 and later can be controlled from a PLC or other master device via serial communications using the Modbus RTU protocol.

Modbus communications can be configured using the master and up to 31 slaves. The drive has slave function only, and serial communication is normally initiated from the master and responded to by the slave(s).

The master performs the serial communications with only one slave at a time. The address or node for each slave must be set beforehand so the master can communicate with the slave at that address. A slave that receives a command from the master will perform the specified function and then send a response back to the master.

Communication Interface: RS-232 (RS-485 to RS-232 converter must be used for bus communication)
Format: 8 data bits, 1 stop bit

Serial Link Connections

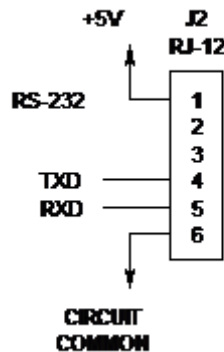

Figure 13: Serial Link Connections

Communications Timing

To prevent overrun in the slave drive, the master should wait a minimum of 15 ms between sending messages to the same drive.

Message Format

In Modbus communications, the master sends commands to the slave, and the slave responds. The message format is configured for both sending and receiving as shown below, and the length of the packets depends on the command content.

SLAVE ADDRESS
FUNCTION CODE
DATA
ERROR CHECK (CRC)

The slave address in the message defines the node the message is sent to. Use addresses between 1 and 31 (hex). The response from the slave will use an address 0 to the master.

The OmniPulse DSD supports the three Modbus function codes shown below:

Function Code	Function Name	Data Length			
		Command Message		Response Message	
		Minimum	Maximum	Minimum	Maximum
03H	Read Modbus registers	8	8	7	37
08H	Loopback test	8	8	8	8
10H	Write to multiple Modbus registers	11	41	8	8

Command Registers

It is possible to both read and write control data to the control registers.

The following tables define the available OmniPulse DSD Modbus control registers:

Register No.	Contents	Access
0002H	Speed Reference (units 000.00 PU)	RD/WR
0003H	Torque Reference (units 00.000) Bipolar	RD/WR
0005H	Save/Recall Function (#994) 0 = No Action 1 = Save NVRAM 2 = Restore NVRAM	RD/WR

If parameter values are changed, the Save/Recall Function must be set to a 1 to save parameters to NVRAM.

When Speed Mode Select (Parameter 30) is set to 4 or 5 a speed demand can be applied in one of two manners:

1. Set either bit 0 or 1 of register 0001H to logic 1 to select the direction, and set a speed reference in register 0002H.
2. Set either bit 0 or 1 of register 0001H to a 1 to select the direction; if Multi-Function Input Selects (Parameters 71-79) are set to 1-5, set bits 4-9 of register 0001H to logic 1.

I/O Registers

It is possible to read I/O data from the drive.

Register No.	Contents	Access	
0010H	Multi-function Digital Inputs	RD	
	Bit 0		Forward Run (0 = Stop, 1 = Forward Run)
	Bit 1		Reverse Run (0 = Stop, 1 = Reverse Run)
	Bit 2		MFDI 1
	Bit 3		MFDI 2
	Bit 4		MFDI 3
	Bit 5		MFDI 4
	Bit 6		MFDI 5
	Bit 7		MFDI 6
	Bit 8		MFDI 7
	Bit 9		MFDI 8
	Bit 10		MFDI 9
	Bit 11		Reserved
	Bit 12		Reserved
Bits 13-15	Reserved		
0011H	Multi-function Digital Outputs	RD	
	Bit 0		K1
	Bit 1		K2
	Bit 2		K3
	Bit 3		K4
	Bit 4		K5
	Bit 5		K6
Bit 6	K7		
0012H	Multi-function Analog Input 1	RD	
0013H	Multi-function Analog Input 2	RD	
0014H	Multi-function Analog Output 1	RD	
0015H	Multi-function Analog Output 2	RD	

Fault and Error Registers

It is possible to read Fault and Error data from the drive.

Register No.	Contents	Access
0020H	Fault 0	RD
0021H	Fault 1	RD
0022H	Fault 2	RD
0023H	Fault 3	RD
0024H	Fault 4	RD
0025H	Fault 5	RD
0026H	Fault 6	RD
0027H	Fault 7	RD
0028H	Fault 8	RD
0029H	Fault 9	RD
002AH	Fault 10	RD
002BH	Fault 11	RD
002CH	Fault 12	RD
002DH	Fault 13	RD

Register No.	Contents	Access
002EH	Fault 14	RD
002FH	Fault 15	RD
0030H	Error 0	RD
0031H	Error 1	RD
0032H	Error 2	RD
0033H	Error 3	RD
0034H	Error 4	RD
0035H	Error 5	RD
0036H	Error 6	RD
0037H	Error 7	RD
0038H	Error 8	RD
0039H	Error 9	RD
003AH	Error 10	RD
003BH	Error 11	RD
003CH	Error 12	RD
003DH	Error 13	RD
003EH	Error 14	RD
003FH	Error 15	RD

Parameter and Monitor Registers

It is possible to both read and write parameter data to parameter registers. It is possible to read monitor data from monitor registers.

Function #	Description	Units	Format	Register #
1	Rated Armature Volts	VDC	0 DP	0065H
2	Rated Armature Amps	ADC	1 DP	0066H
3	Rated Motor RPM	RPM	1 DP	0067H
4	Manual Armature Inductance	HNY	4 DP	0068H
5	Manual Armature Resistance	Ohm	3 DP	0069H
6	Rated Field Current	ADC	2 DP	006AH
7	Rated Field Volts	VDC	0 DP	006BH
8	Manual Field L/R	Sec	2 DP	006CH
9	Weak Field Current	ADC	2 DP	006DH
10	Nominal AC Voltage	VAC	0 DP	006EH
11	Field Source Volts AC	VAC	0 DP	006FH
12	Encoder Pulses/Rev.	P/R	0 DP	0070H
13	Absolute Maximum RPM	RPM	0 DP	0071H
14	Maximum Armature Current	%	0 DP	0072H
15	Encoder Feedback On	Logic	Binary	0073H
16	Armature Voltage @ Maximum Speed	VDC	0 DP	0074H
17	Standby Field Current	%	0 DP	0075H
18	Field Regulator Response	RAD	1 DP	0076H
19	3 Second Motor Contactor Fault	Logic	Binary	0077H
20	Use Self Tune	Logic	Binary	0078H
21	Armature Current Response	RAD	0 DP	0079H
22	Speed Regulator Response	RAD	1 DP	007AH
23	System PU Inertia	SEC	2 DP	007BH
24	Speed Stability	PU	1 DP	007CH

Function #	Description	Units	Format	Register #
26	Position Damping	PU	2 DP	007EH
27	Acceleration Time	Sec	2 DP	007FH
28	Deceleration Time	Sec	2 DP	0080H
29	Analog Source Select	Logic	Binary	0081H
30	Speed Mode Select	# Select	0 DP	0082H
31	Preset Speed 1	%	1 DP	0083H
32	Preset Speed 2	%	1 DP	0084H
33	Preset Speed 3	%	1 DP	0085H
34	Preset Speed 4	%	1 DP	0086H
35	Preset Speed 5	%	1 DP	0087H
36	Preset Speed 6	%	1 DP	0088H
37	Preset Speed 7	%	1 DP	0089H
38	Micro –Speed 1 Gain	PU	2 DP	008AH
39	Micro –Speed 2 Gain	PU	2 DP	008BH
40	Start – Stop Mode	# Select	0 DP	008CH
41	Brake Release Timer	Sec	1 DP	008DH
42	Brake Set Timer	Sec	1 DP	008EH
43	Load Float Time	Sec	0 DP	008FH
44	Answer-Back Time	Sec	2 DP	0090H
45	Brake Slip Timer	Sec	1 DP	0091H
46	Maximum Brake Slip	Pulses	0 DP	0092H
47	Brake Release Check Time	Sec	2 DP	0093H
48	Brake Release Movement	Pulses	0 DP	0094H
49	Brake Fault Speed	%	1 DP	0095H
50	IFBK OK Timer	Sec	2 DP	0096H
51	Bipolar Analog Input T68	Logic	Binary	0097H
52	Analog Input T68 Bias	PU	3 DP	0098H
53	Analog Input T68 Gain	PU	3 DP	0099H
55	Bipolar Analog Input T76	Logic	Binary	009BH
57	Analog Input T76 Bias	PU	3 DP	009DH
58	Analog Input T76 Gain	PU	3 DP	009EH
60	Analog Output T45	# Select	0 DP	00A0H
61	Analog Output T45 Bias	PU	2 DP	00A1H
62	Analog Output T45 Gain	PU	2 DP	00A2H
65	Analog Output T46	# Select	0 DP	00A5H
66	Analog Output T46 Bias	PU	2 DP	00A6H
67	Analog Output T46 Gain	PU	2 DP	00A7H
71	Multi-Function Input T_9_Select	# Select	0 DP	00ABH
72	Multi-Function Input T_10_Select	# Select	0 DP	00ACH
73	Multi-Function Input T_11_Select	# Select	0 DP	00ADH
74	Multi-Function Input T_12_Select	# Select	0 DP	00AEH
75	Multi-Function Input T_50_Select	# Select	0 DP	00AFH
76	Multi-Function Input T_51_Select	# Select	0 DP	00B0H
77	Multi-Function Input T_52_Select	# Select	0 DP	00B1H
78	Multi-Function Input T_53_Select	# Select	0 DP	00B2H
79	Multi-Function Input T_54_Select	# Select	0 DP	00B3H
81	K1_Logic_Out_Select	# Select	0 DP	00B5H

Function #	Description	Units	Format	Register #
82	K2 Logic Out Select	# Select	0 DP	00B6H
83	K3 Logic Out Select	# Select	0 DP	00B7H
84	K4 Logic Out Select	# Select	0 DP	00B8H
85	K5 Logic Out Select	# Select	0 DP	00B9H
86	K6 Logic Out Select	# Select	0 DP	00BAH
87	K7 Logic Out Select	# Select	0 DP	00BBH
90	Full Field Detect	%	0 DP	00BEH
91	Zero Speed Threshold	%	2 DP	00BFH
92	Inch Timer	Sec	1 DP	00C0H
93	Torque Decay Time	Sec	2 DP	00C1H
94	Overspeed Trip	%	1 DP	00C2H
95	Encoder Sense Voltage	%	1 DP	00C3H
96	Encoder Sense Speed	%	1 DP	00C4H
98	Motor Overload Current	PU	2 DP	00C6H
99	Motor Overload Time	Sec	1 DP	00C7H
100	Initial Starting Torque	%	0 DP	00C8H
101	Minimum Starting Torque	%	0 DP	00C9H
102	Regen Margin	PU	2 DP	00CAH
103	Down Starting Current Limit	%	0 DP	00CBH
104	Torque Regulator Gain	PU	0 DP	00CCH
110	Ultra Lift Mode	# Select	0 DP	00D2H
111	Ultra Lift Threshold Speed	%	0 DP	00D3H
112	Ultra Lift Maximum Speed	%	0 DP	00D4H
113	Ultra Lift Maximum Current	%	0 DP	00D5H
114	Ultra Check Time	Sec	1 DP	00D6H
120	Protocol Select	# Select	0 DP	00DCH
121	Modbus Baud Rate	# Select	0 DP	00DDH
122	Modbus Address	NUM	0 DP	00DEH
123	Modbus Parity	# Select	0 DP	00DFH
124	Modbus Communication Timeout	Sec	3 DP	00E0H
600	Ramped Speed Reference	PU	3 DP	02BCH
601	Motor RPM	RPM	1 DP	02BDH
602	Speed Command Reference	PU	3 DP	02BEH
608	Armature Current Reference	PU	3 DP	02C4H
609	Motor CEMF	VDC	1 DP	02C5H
610	Motor Armature Voltage	VDC	1 DP	02C6H
611	Motor Armature Current	ADC	1 DP	02C7H
612	Motor Field Current	ADC	2 DP	02C8H
613	Measured R	OHM	3 DP	02C9H
614	Measured L	HNY	4 DP	02CAH
615	Measured Field L/R	Sec	3 DP	02CBH
617	Line Frequency	Hz	1 DP	02CDH
618	Heatsink Temperature	C	0 DP	02CEH
619	AC Line Volts	VAC	1 DP	02CFH
620	Brake Slip	NUM	0 DP	02D0H
668	Analog Speed Command	%	2 DP	0300H

Function #	Description	Units	Format	Register #
676	Analog Torque Reference	PU	3 DP	0308H
688	Cube ID Number	NUM	0 DP	0315H
689	Field ID Number	NUM	0 DP	0316H
692	Day	NUM	0 DP	0318H
693	Month	NUM	0 DP	0319H
695	Year	NUM	0 DP	031BH
696	Beta P	NUM	0 DP	031CH
697	Version SA	NUM	0 DP	031DH
698	Software Release	NUM	0 DP	031EH
699	Customer ID	NUM	0 DP	031FH

The numeric format is defined by the number of decimal point digits (DP). A number with a format 3 DP would be represented as XX.XXX or have a scientific notation of XXXXX * 10⁻³.

Drive Faults

The following Faults are custom to the OMNIPULSE DSD crane control software.

FUNCTION ERROR CODE LISTING

*** DCU ERRORS ***

DISPLAY # - DESCRIPTION

13 = ILLEGAL INSTRUCTION
14 = LINE 1010 EMULATOR
15 = LINE 1111 EMULATOR
16 = PRIVELEGE VIOLATION
17 = DIVIDE BY ZERO
21 = WATCHDOG TIMEOUT
22 = RESERVED INTERRUPT
23 = UNINITIALIZED INTERRUPT
24 = TRACE EXCEPTION
26 = SPURIOUS EXCEPTION
97 = OVERSPEED TRIP
98 = TACH/ENCODER LOSS
99 = REVERSE TACH/ENCODER
100 = NOT A NUMBER
101= MATH OVERFLOW
102 = MATH UNDERFLOW
103 = FLOATING POINT DIVIDE BY ZERO
104 = SIGN ERROR IN SPEED REG
112 = BAD PCDU POINTER
113 = MISSING PCU
114 = LOCKED UP QUEUES
115 = MULTIPLEXER CONFIG. ERROR
220 = DCU ROM BUS ERROR
221 = DCU RAM BUS ERROR
222 = DCU NVRAM BUS ERROR
223 = DCU DPRAM BUS ERROR
232 = UNKNOWN BUS ERROR
240 = DCU ROM BUS ERROR
241 = DCU RAM ADDRESS ERROR
242 = DCU NVRAM ADDRESS ERROR
243 = DCU DPRAM ADDRESS ERROR
252 = UNKNOWN ADDRESS ERROR

DRIVE FAULTS/ERRORS

DISPLAY # - DESCRIPTION

400 = MOTOR OVERLOAD
401 = BRAKE HOLD FAULT
402 = CONTACTOR FAULT
403 = BRAKE ANSWER-BACK FAULT
404 = ARMATURE CIRCUIT FAULT
405 = SAFETY CIRCUIT FAULT

406 = 10% LOW LINE ALARM
407 = EXCESSIVE CEMF ALARM
408 = EXCESSIVE PCU CEMF FAULT
409 = UNEXPECTED PCU RESET
410 = BRAKE RELEASE FAULT
411 = EXTERNAL FAULT
412 = TORQUE LIMIT FAULT
413 = PRE-TORQUE FAULT
414 = MODBUS COMM FAULT

*** PCU ERRORS ***

DISPLAY # - DESCRIPTION

900 = PCU LOOP FAULT
901 = PCU IST FAULT
902 = POWER SUPPLY FAULT
903 = LINE SYNC FAILURE
904 = LOW LINE FAULT
905 = FIELD LOSS
906 = DCU FAILURE
907 = THERMISTOR FAULT
908 = OVER TEMPERATURE
909 = EXCESSIVE RIPPLE
910 = BLOWN FUSE
911 = SHORTED SCR
912 = OPEN SCR
915 = PARAMETER SETUP FAULT
916 = FORCING FAULT
917 = REVERSE ARM. V. FEEDBACK
919 = RATED VAC. SETTING ERROR
920 = RATED ARM. VOLT. SETTING
921 = BRIDGE RATING FAULT
923 = RATED ARM. I. SETTING ERROR
924 = RATED FIELD I. SETTING ERROR
925 = FIELD PCB SENSE FAULT
926 = PCU WATCHDOG TIMEOUT FAULT
929 = FIELD CURR. WON'T GO TO ZERO
930 = FIELD CURR. WON'T GO TO RATED
931 = OPEN CIRCUIT CEMF FAULT
932 = CLOSED CIRCUIT CEMF FAULT
933 = ARM CURRENT WON'T INCREASE
934 = LOW ARM INDUCTANCE
935 = WRONG BUS VS ARM VOLTS FBK
936 = E-STOP OPENED DURING TEST
937 = LOW ARMATURE VOLTS FBK
938 = LOW BUS VOLTS FBK
Prot = CORRUPTED NV RAM DATA

CHAPTER 5: TROUBLESHOOTING

Table 4.6 provides a description of drive faults and basic troubleshooting steps to find and correct the problem.

FAULT CODE DESCRIPTIONS & DIAGNOSTICS

ERROR/FAULT CODE	PROBABLE CAUSE — CORRECTIVE ACTION
400	<p>MOTOR OVER LOAD FAULT --- Indicates that the drive has delivered excess motor amps for a significant period of time. Refer to parameters #98 and #99 for proper set-up. Check for a dragging brake or overly weakened motor field. A motor overload fault does not automatically shut down the drive, but is annunciated via the ALARM logic output when enabled. The yellow Over-Load LED will also be ON when an Over-Load Fault has occurred.</p>
401	<p>BRAKE HOLD FAULT --- Indicates that the hoist brake has shown excessive slip when expected to hold the load. – Causes:</p> <ol style="list-style-type: none"> 1. Electrical problem. Start from the programmed output at TB1, ensure that power to the Brake coil does indeed de-energize at the end of Load Float. 2. Mechanical problem. Ensure that the Brake does indeed engage when the coil is de-energized. Check Brake shoes for mechanical problems, wear, dirt or grease contamination. 3. Brake Slip threshold adjustment (#46) is set too tight. Increase (#46) slightly to avoid nuisance trips. 4. Brake Set time adjustment (#42) is too small. Drive starts torque decay before brake is set. Increase (#42) to allow sufficient time for brake to set. 5. Motor circuit interrupted while still holding the load. Verify that the E-Stop and TB1(7) circuits remain energized until after the drive has opened the contactor. 6. Over loaded hoist. Lower the load and remove load weight.
402	<p>MOTOR CONTACTOR FAULT— The Motor Contactor auxiliary contact does not pick up or drop out within the designated time as requested by the drive. See Param. #19. – Causes:</p> <ol style="list-style-type: none"> 1. Defective Motor Contactor Aux. Check for proper feedback at TB1(7) 2. Defective Contactor. Check for open coil or mechanical binding. 3. Defective Motor Contactor Pilot Relay, if used. Verify proper operation. 4. Interference from other noisy controls or power relay circuits. Verify proper equipment grounding.
403	<p>BRAKE ANSWER-BACK FAULT – Indicates that the brake answer-back contact did/does not agree with the status of brake energization within time set at (#44).</p> <ol style="list-style-type: none"> 1. Verify that the Brake answer-back contact does indeed work and that the MFI input is properly programmed. 2. If there is no answer-back contact set (#40) to 1 or 2. 3. Adjust the setting of (#44) to allow adequate time for answer-back.

FAULT CODE DESCRIPTIONS & DIAGNOSTICS cont'd

ERROR/FAULT CODE	PROBABLE CAUSE — CORRECTIVE ACTION
404	OPEN ARMATURE CIRCUIT – A large current error existed for ½ second. Check the DC link fuse. Check motor armature circuit wiring. Check power poles in the DC loop contactor.
405	E-STOP CIRCUIT FAULT — The Safety Circuit is not closed. The Drive has detected that the Safety Circuit wired between TB3-3 and TB3-6 on the Power Supply A4 was not closed for 100 msec before an Up or Down command was given, or that it opened unexpectedly while the motor contactor was closed. Check for intermittent connections in the E-Stop circuit. Verify that the E-Stop line remains closed until the drive de-energizes the motor contactor.
406	LOW LINE ALARM – Indicates that the input AC line voltage sagged more than 10% below nominal line volts as set at Parameter #10. This does not shut down the drive but may be an indication that work is needed to avoid future Low Line shut down faults, F904.
407	CEMF ALARM - The CEMF of the motor exceeded 109% of measured AC input voltage to the Drive. This is a warning only and does not cause an automatic drive shut down. – Causes: <ol style="list-style-type: none"> 1. Insufficient VAC input (#10) as necessary to support motor voltage (#1) 2. 3-phase input AC Line Voltage drooped under load or is too low. 3. Motor field current set too high. Verify motor field current set point (#6) Vs desired motor voltage maximum speed (#13). 4. Check & correct speed regulator tuning to prevent speed and CEMF overshoot. Review and verify settings for #22, #23, #24, & #26.
408	PCU CEMF FAULT - The CEMF of the motor exceeded 118% of the rated VAC input voltage to the Drive. This fault causes a drive shut down to prevent fuse blowing. – Causes: <ol style="list-style-type: none"> 1. 3 Phase Input AC Line Voltage is low. Check and correct. 2. Incorrect motor field current setting or field regulator mis-operation causing excessive CEMF. Check & correct. 3. Excessive drive speed overshoot. Correct with velocity regulator adjustments.
409	PCU RESET — PCU processor was unexpectedly reset. Verify that correct PCU software and revision level is being used. Possible problem with main circuit card hardware. Look for external noise interference. Ensure that equipment and signal grounding connections are proper. Correct as necessary. If problem remains, replace main PCB.

FAULT CODE DESCRIPTIONS & DIAGNOSTICS cont'd

<p>410</p>	<p>BRAKE RELEASE FAULT --- Indicates that the brake failed to release within (#47) seconds when told to do so. Actual release is determined by encoder movement of (#48) counts before time (#47).</p> <ol style="list-style-type: none"> 1. Ensure that the brake does indeed release when told to do so. Check electrical and mechanical components. 2. Ensure that the selected speed (#31 – 36) and acceleration rate (#27) will cause the encoder to move within time (#47). Extend measurement time (#47), increase the starting speed, or reduce the acceleration time (#27). 3. Ensure that the encoder counts to determine brake release at (#48) are realistic. Lower the setting of expected counts (#48).
<p>411</p>	<p>EXTERNAL FAULT --- Indicates that the External Fault signal was given. An external or internal fault RESET must be received after the External Fault signal has been removed in order to clear this fault.</p>
<p>412</p>	<p>TORQUE LIMIT FAULT – This fault will occur if operating conditions cause the drive to be in current limit for longer than 3 seconds. Verify that:</p> <ol style="list-style-type: none"> 1. Maximum Armature Current setting (#14) is correct. 2. Motor Field Current setting (#6) is correct. 3. The brake is not stuck or the machine jammed.
<p>413</p>	<p>PRE-TORQUE FAULT- Before the brake is released, the drive's armature/field current did not reach a predetermined level within a predetermined time.</p>
<p>414</p>	<p>MODBUS COMM FAULT-Communications were lost with Modbus master while a Modbus control register applied a RUN command. Verify that:</p> <ol style="list-style-type: none"> 1. Modbus Time-out (#124) setting is correct. 2. Communication cable is properly connected.
<p>" P.L. "</p>	<p>POWER LOSS - Loss of 115VAC control power. — Check cable connection at TB3 of Power Supply Assembly A4. Ensure that control power is always above 92 VAC.</p>
<p>" - - - "</p>	<p>BLOWN FUSES or loss of 3 phase input power. – Check for blown line fuses. If fuses are not blown, verify that AC input voltage to drive is present. Verify that power supply voltages are valid at TP1, 2, 3, & 4 on the main PCB. Check connections to the Armature Interface PCB and ribbon cable at J4.</p>

FAULT CODE DESCRIPTIONS & DIAGNOSTICS cont'd

ERROR/FAULT CODE	PROBABLE CAUSE — CORRECTIVE ACTION
<p>13-17, 21-26, 100-104, 112-114, 220-234, 240-254, 926</p>	<p>MISC FAULTS - Problem with either hardware or software on the Drive Control PCB. See list at Section 4.5.</p> <ol style="list-style-type: none"> 1. Check and/or replace U13, U14, U39, and U40 (EPROMs). 2. Replace Drive Control PCB A1. 3. Call Magnetek Service at 866.MAG.SERV for assistance.
<p>97</p>	<p>OVERSPEED FAULT - The motor speed has exceeded the trip level set in Parameter #94, as measured by the encoder. Parameter #94 is a percentage of the motor speed value set in Parameter #3. Possible cause</p> <ol style="list-style-type: none"> 1. Incorrect setting of Parameters #3, #12 or #94. 2. Poor speed regulator tuning - Check parameters #22, 23 & 24 3. Velocity reference set above rated speed. 4. Intermittent velocity encoder.
<p>98</p>	<p>ENCODER LOSS FAULT - The drive does not see the encoder velocity in proportion to armature voltage indication of speed. Refer to Parameter explanations for #95 and #96.</p> <ol style="list-style-type: none"> 1. Ensure that the encoder is working. Look for loose connections. 2. Raise the value for #95 if motor has high resistance. 3. Ensure that the contactor feedback circuit at TB1(7) does not close before the armature power poles. See timing diagram Fig. 4.4.7.
<p>99</p>	<p>REVERSED ENCODER FAULT — The digital encoder and motor voltage signals do not agree in direction of rotation. Probable cause: Encoder leads are reversed. Reverse connections for A and ANOT.</p>
<p>900</p>	<p>MOTOR CONTACTOR FAULT - The contactor did not close or opened unexpectedly. Or the motor voltage exceeded 30% of rated motor voltage (F#7) during Self-Tune (F#997). When this occurs, the Severe Fault flag is set and the OMNIPULSE DSD current reference is forced to zero. This fault will shutdown the drive.</p> <ol style="list-style-type: none"> 1. Check the contactor aux feedback circuit to TB1(7). 2. Check contactor and pilot relay coils (if used) for proper operation. 3. Check that power is being applied to LPR from the power supply at TB3(5). (Will be momentary until F900 occurs.) If not there, suspect an internal relay failure. Replace A4, Power Supply PCB.
<p>901</p>	<p>PCU IST FAULT – Current flow in excess of 300% of rated armature current detected. Check for:</p> <ol style="list-style-type: none"> 1. Ground fault or intermittent connection in motor armature circuit. 2. Faulty current measuring module. 3. Poor current regulator tuning.

FAULT CODE DESCRIPTIONS & DIAGNOSTICS cont'd

ERROR/FAULT CODE	PROBABLE CAUSE — CORRECTIVE ACTION
<p>902</p>	<p>POWER SUPPLY FAULT (CPU Reset Required) The Low Voltage Power Supply (A4) output has dropped below 60% of the rated voltage. This fault will shutdown the drive. Possible causes;</p> <ol style="list-style-type: none"> 1. Loss of 115VAC power. 2. Short circuits in +5V, +/-15V, or +24V circuits, possibly external to the drive. 3. Failed Power Supply 4. Blown fuse internal to power supply.
<p>903</p>	<p>LINE SYNCHRONIZATION FAULT (CPU Reset Required) The Phase Locked Loop has lost synchronization with the 3 Phase AC input power supply. When this occurs, the Severe Fault flag is set and the current reference is forced to zero. Generally this is caused by AC input power problems and is self correcting. This fault will shutdown the Drive. This fault will often occur with a F904 fault.</p>
<p>904</p>	<p>LOW LINE VOLTAGE FAULT The AC input power has dropped below 80% of the Nominal AC Line Voltage (F#10) for 3 consecutive cycles or lower than 50% for one cycle. When this occurs, the Severe Fault flag is set and the OMNIPULSE DSD current reference is forced to zero. This fault will shutdown the Drive.</p>
<p>905</p>	<p>FIELD LOSS FAULT This fault will shutdown the Drive. The field current feedback has dropped below 80% of the expected current during the following conditions:</p> <ol style="list-style-type: none"> 1. F#9 when Drive is in Field Weakening Mode (Top speed). 2. F#6 when Drive is in Full Field Mode (Accel or Decel). 3. F#17 when Drive is in Standing Field Mode (not running). <p>Probable causes are:</p> <ol style="list-style-type: none"> 1. Open circuit failure of motor field or motor field wiring. 2. Hardware failure of motor field control circuitry. 3. Loss of power or incorrect phasing to Field Rectifier.
<p>906</p>	<p>DCU FAILURE FAULT (OMNIPULSE DSD Power down is required.) The update of the Dual Port RAM from the Drive Control Unit (DCU) is unreliable. This requires the replacement of the Drive Control PCB, A1. This fault will shutdown the drive.</p>
<p>907</p>	<p>THERMISTOR FAULT --- The thermistor is found to be open or shorted. Check and/or replace the thermistor. It should measure between 2K – 10K ohms at 20C room temperature. A Thermistor Fault will also occur if the machine room ambient temperature is below 0C as the resistance it is detected as too high to be measured. This fault will not shutdown the Drive.</p>

FAULT CODE DESCRIPTIONS & DIAGNOSTICS cont'd

ERROR/FAULT CODE(S)	PROBABLE CAUSE - CORRECTIVE ACTION
908	<p>OVER TEMPERATURE FAULT - The calculated SCR junction temperature is above 125 degrees Centigrade. This is calculated from the thermistor heatsink measurement and measured armature output current heating effects of SCRs. Possible causes:</p> <ol style="list-style-type: none"> 1. Ambient temperature too high. Check for cause. 2. Clogged air filter in cabinet. Clean or replace air filter. 3. Clogged heatsinks. Clean heatsink fins. 4. Cooling fan failure. Replace defective cooling fan(s) in power cube. <p>Note: This fault will not shutdown the Drive.</p>
909	<p>RIPPLE FAULT - Repeated high peak to average motor armature current. The cause of this condition may be defective hardware, which can be discovered through the PCU Diagnostics function, #998. It may also occur due to poor regulator tuning or other oscillatory operation condition. See Magnetek Application Note OMNIPULSE DSD 412-103 for a complete explanation of this fault.</p>
910	<p>BLOWN FUSE FAULT - One or more of the three AC line fuses is open. This condition is checked on power-up and upon request through the PCU Diagnostics function, #998. Detection is accomplished by measurements via voltage dividers on the Armature Interface PCB, A2. Possible causes are;</p> <ol style="list-style-type: none"> 1. One or more of AC input fuses are blown. 2. Power wiring problem-check wiring. 3. Faulty DSPR power relay.
911	<p>SHORTED SCRS/DOUBLER FAULT - (OMNIPULSE DSD Power Down is required.) One of the SCR/Doubler packs has a short circuit between the SCRS. This condition is checked only upon request through the PCU Diagnostics function, #998. The optional handheld PCDU will also identify which SCR pair is bad.</p>
912	<p>OPEN SCR FAULT (OMNIPULSE DSD Power Down is required.) One of the SCRs does not conduct current. This condition is checked only upon request through the PCU Diagnostics function, #998. The optional handheld PCDU will also identify which SCR pair is bad. Check for faulty SCR gating leads.</p>
915	<p>PARAMETER SETUP FAULT (OMNIPULSE DSD powerdown is required.) One of the following parameters is not within the range of the chassis hardware.</p> <ol style="list-style-type: none"> 1. Rated Volts (F#7) or (F#10) 2. Rated Current (F#2) or (F#6) <p>Corrective action: Enter correct parameter data, save to NVRAM. Reset the drive & re-start.</p>

FAULT CODE DESCRIPTIONS & DIAGNOSTICS cont'd

ERROR/FAULT CODE(S)	PROBABLE CAUSE - CORRECTIVE ACTION
916	FORCING FAULT – The prohibit rotation bit was removed with the loop picked-up. This fault can only occur when using the handheld PCDU.
917	REVERSE ARMATURE POLARITY - (Drive power down is required.) This fault will show up when doing the F998 PCU Diagnostics Test. It indicates that the polarity of the Armature Voltage Feedback wires are reversed or missing. Check connections on TB5-1 and TB5-2 of the Armature Interface PCB, A2. F909 faults and/or very poor drive/ride performance may occur if not corrected.
919	LINE VOLTAGE SETTING FAULT (Drive power down is required.) This fault is declared if a number is entered for the Nominal AC Input Voltage (F#10) that is outside the acceptable range of 150 to 525 VAC. If 0 is entered, the rated line voltage defaults to 230 or 460 VAC depending on the line voltage sensed.
920	LOAD VOLTAGE SETTING FAULT (Drive powerdown is required.) Declared if the Rated Armature Voltage (F#1) value is outside the acceptable range of 150 to 550 VDC.
921	BRIDGE RATING FAULT (Drive power down is required.) The bridge type is determined by reading a sense resistor on the Cube ID PCB plugged into the A2 Armature Interface PCB. The resistor value identifies the ampere rating and current feedback scaling of the physical hardware. This failure occurs if the computer cannot identify the drive size. Possible causes: <ol style="list-style-type: none"> 1. J14 on Main Control PCB is not seated properly. 2. Missing or wrong Cube ID PCB. 3. Wrong PCU software in U13 & 14. 4. Faulty Armature Interface PCB – replace PCB. 5. Faulty Drive Control PCB – replace PCB.
923	LOAD CURRENT SETTING FAULT - (Drive power down is required.) This fault is declared if a number is entered for Rated Armature Current, F#2 that is outside the acceptable range of 0.125 to 2.0 times the bridge current rating as determined by the bridge sense resistor on the Cube ID PCB, on the Armature Interface PCB.
924	FIELD CURRENT SETTING FAULT (Drive power down is required.) This fault is declared if a number is entered for Rated Field Current F#6 that is outside the acceptable range of the Field Interface board, A3 current rating as determined by the field sense resistor selected by SW1 on the Field Interface PCB.

FAULT CODE DESCRIPTIONS & DIAGNOSTICS cont'd

ERROR/FAULT CODE(S)	PROBABLE CAUSE -CORRECTIVE ACTION
<p>925</p>	<p>FIELD SENSE FAULT - (Drive power down is required.) The field bridge rating is determined by reading a sense resistor on the Field Interface board selected by SW1. This resistance identifies the motor field current feedback scaling for the A/D converter. If the resistance value is not recognized a Field Sense Fault is declared. This indicates that there is a hardware fault on the Field Interface PCB, Drive Control PCB, or within the interconnecting cables and hardware. Check that J13 is seated properly and that the cable is not defective.</p>
<p>926</p>	<p>PCU WATCHDOG - (Drive power down is required.) This fault is declared when the PCU is reset via its own software watchdog timer. It is an indication of a PCB hardware problem more so than a DCU or PCU software problem. A likely cause is severe electrical interference. Check for:</p> <ol style="list-style-type: none"> 1. Faulty EPROMs or socket connections at U13, U14, U39 or U40. 2. Ensure that all panel relays have working R/C coil suppression. Include relays that may be operating door opener equipment. 5. Look for relays where the +24V and 115VAC signals are being switched in the same relay. There must be arc barriers between contact poles to avoid "spark splash" from 115 VAC circuits into 24 VDC logic. 6. Check for intermittent grounds in the power circuit and in 24VDC signal wiring. 7. Noise generated over the encoder feedback, power supply, or Drive Control PCB can cause this fault. Verify all connections and verify that the Drive Control PCB is properly grounded. <p>This fault is usually caused by electrical noise causing the Drive's micro-processor to malfunction.</p>
<p>Prot</p>	<p>CORRUPTED NVRAM DATA – The NVRAM has lost parameter set up data. This fault will occur if the battery within NVRAM chip U56 is weak. The drive display will show 'Prot' if a loss of data is detected when power has been re-applied, and the processor attempts to load in default values while the NV-Protect switch is in the 'safe' ON position. MagneTek recommends replacing U56 every 8 years.</p>

FAULT CODE DESCRIPTIONS & DIAGNOSTICS cont'd

OTHER CONDITIONS	PROBABLE CAUSE - CORRECTIVE ACTION
<p>NO LED DISPLAY WITH POWER ON</p>	<p>No power at TB3 or failed power supply.</p> <ol style="list-style-type: none"> 1. Verify 115 VAC control voltage at TB3(1 & 2) 2. Verify that cable J11 is seated properly. 3. Short circuit on external wiring dragging down the power supply. Verify by temporary removal of wires at TB1(48, 82, & 1). If display operation is restored. fix external problem. 4. Short circuit internal to current measuring transducer. Verify by removal of J27. If display operation is restored, replace the current transducer. DO NOT RUN THE DRIVE WITH CURRENT TRANSDUCER DISCONNECTED.
<p>LOSS OF STORED PARAMETER DATA</p>	<p>Severe electrical disturbance with NV-Protect switch in OFF position, or failure to actually save the data, or weak battery within U56.</p> <ol style="list-style-type: none"> 1. Remember to SAVE the data when parameters are changed. See Section 3.6 2. Return NV-Protect switch to ON when parameter data changes are completed. See Section 3.6 <p>Replace U56. MagneTek recommends replacing U56 every 8 years.</p>
<p>DRIVE DISPLAY INDICATES BLOWN FUSES WHEN ALL FUSES TEST GOOD WITH OHMMETER</p>	<p>Control power applied before 3-phase armature supply. Short circuit in +/-15 V wiring circuits prevents analog circuit measurements from working.</p> <ol style="list-style-type: none"> 1. Verify that 3-phase power and control power are supplied simultaneously. Or that drive faults will be RESET by external circuits after 3-phase power is applied. 2. Read power supply voltages at test points near the top front of PCB A1. TP8 is circuit common. TP1, 2, 3, & 4 (just below J11, to right of silver metal can U8) should be +24V, +15V, -15V, +5V, +/-5% respectively. 3. If voltages in step 2 are low, unplug ribbon cables at J13 and J14 (A1 PCB, lower left). If power supply voltages are restored, pursue cause of short circuit on those cables. Suspect faulty current transducer or cable. 4. Remove power supply cover. Disconnect power supply at J11. Re-measure voltages at marked test points on power supply PCB. If voltages are OK with J11 disconnected and fault was not found in step 3, replace main PCB.
<p>REPEATED FALSE OVER-TEMPERATURE INDICATIONS</p>	<p>Leakage current between the thermistor on the heatsink and the thermistor leads can cause an elevated temperature to be measured. Replace failing thermistor and/or thermostats.</p>

FAULT CODE DESCRIPTIONS & DIAGNOSTICS cont'd

The following fault codes may occur during Self-Tune (Fctn #997) or Self-Diagnostic (Fctn #998).

ERROR/FAULT CODE(S)	PROBABLE CAUSE - CORRECTIVE ACTION
F929	<p>Motor field current does not reduce to near zero within 6 seconds. Verify motor field current with an independent clamp-on DC ammeter.</p> <p>Probable causes:</p> <ol style="list-style-type: none"> 1. Incorrect phasing of VAC supply to field control module. Provide correct single phase supply wiring. 2. Faulty SCR/Rectifier power module for motor field. Replace.
F930	<p>Motor field current does not increase to near rated amperes within 6 seconds. Verify motor field current with an independent clamp-on DC ammeter.</p> <p>Probable causes:</p> <ol style="list-style-type: none"> 1. Motor field not connected. 3. Not enough voltage available to achieve rated field current. Maximum VDC output to motor field is 0.9 X VAC input at terminals A3TB1, AC1 & AC2. At -10% low line, the maximum VDC output is 0.8 x VAC. If this voltage is not enough to produce rated field current through the resistance of the motor field winding, reconnect the field windings for lower voltage (and higher current) or provide a step-up transformer for the motor field circuit. Improper settings for the connected motor field. Insure that the proper current tap at A3TB4 is used, and that calibration switch A3S1 is set correctly, and that adjustments #6, #7, #9, and #11 are set correctly. 2. Faulty SCR/Rectifier power module for motor field. Replace.
F931	<p>Excessive open circuit voltage to motor armature circuit. Measured armature voltage is greater than 10% of rated volts (#1).</p> <p>Probable Causes:</p> <ol style="list-style-type: none"> 1. Motor is rotating, producing CEMF. 2. Unbalanced SCR leakage with low voltage setting of #1. Increase #1 for test. 3. Damaged SCR(s)
F932	<p>Armature CEMF volts >20% of rated during test.</p> <p>Probable causes:</p> <ol style="list-style-type: none"> 1. Motor rotating during the test producing CEMF. 2. High motor armature resistance. Ensure that brush commutator is clean. Temporarily increase Rated Armature Volts, #1 during the test.
F933	<p>Motor armature current does not increase to near test amps within 6 seconds.</p> <p>Probable causes:</p> <ol style="list-style-type: none"> 1. Faulty motor armature circuit. Check wiring and motor for open circuit. 2. Open SCR or missing SCR gating. Perform Self-Diagnostics to verify.

FAULT CODE DESCRIPTIONS & DIAGNOSTICS cont'd

ERROR/FAULT CODE(S)	PROBABLE CAUSE - CORRECTIVE ACTION
F934	Calculated armature inductance is less than 0.00017 Henry. The drive will not Self Tune with less than 170 micro-henries of load inductance. Verify that inductance is really that low. Verify that VAC value at #10 is correct. Manually enter the minimum value into #4. Parameter #20 must be set to OFF.
F935	Calibration of bus voltage and armature voltage feedback circuits do not match. Probable causes: <ol style="list-style-type: none">1. Missing wire to bus or armature voltage feedback circuits.2. Component problem - Feedback voltage divider ratios do not match.
F936	E-Stop contact was opened during test. Test data is not valid. Jumper E-Stop circuit and re-test.
F937	Low read-back volts from motor armature circuit. Probable Causes: <ol style="list-style-type: none">1. Missing wire to armature voltage feedback at TB5.2. Component problem – Feedback voltage divider ratio does not match that identified in Cube ID pcb.
F938	Low read-back volts from DC bus circuit. Probable Causes: <ol style="list-style-type: none">1. Missing wire to bus voltage feedback. (Discrete wires on drives larger than 300 amps DC.)2. Component problem – Feedback voltage divider ratio does not match that identified in Cube ID pcb.

INPUT – OUTPUT SIGNAL VERIFICATION

The Control Display Unit (CDU) function #981 may be used to directly read and track the status of logic input and output signals at OMNIPULSE DSD drive terminals. This is an easy way to verify the integrity of input and output logic signals to the drive. Refer to specific connection diagrams for your application to confirm the definition of how each signal is being used. The I/O indicator technique as described below will work regardless of whether or not the particular terminals and signals are used by internal software logic or actually wired into your application. Function #981 does not work with the Portable Control display Unit.

Here's how to use this valuable troubleshooting tool:

1. Press the Up ▲ or Down ▼ keys and go to F#981.
2. Press the **DATA FCTN KEY**. The green light should turn ON to indicate that data is being displayed.
3. Segments on the local **Control Display Unit** will light up to indicate active input and output logic actions. Vertical segments represent input signals and horizontal segments represent output signals as identified below.

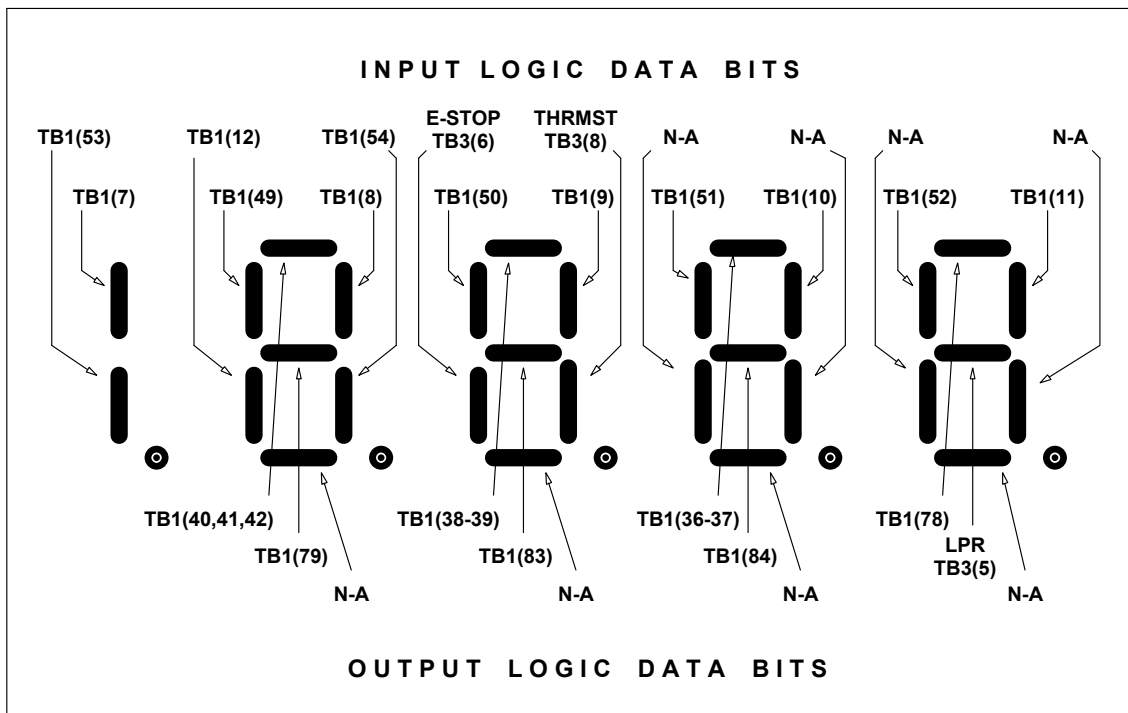

OmniPulse DSD Complete Parameter List

Function #	Description	Units	Range	Default	User Value
1	Rated Armature Volts	VDC	0 - 550	240	
2	Rated Armature Amps	ADC	2.0 - 1250	26	
3	Rated Motor RPM	RPM	50 - 1999	1750	
4	Manual Armature Inductance	HNY	0.001 - 1.000	0.01	
5	Manual Armature Resistance	Ohm	0.001 - 5.000	0.1	
6	Rated Field Current	ADC	0.20 - 40.00	2	
7	Rated Field Volts	VDC	50 - 525	240	
8	Manual Field L/R	Sec	0.10 - 10.00	0.54	
9	Weak Field Current	ADC	0.1 - 40	30	
10	Nominal AC Voltage	VAC	150 - 525	480	
11	Field Source Volts AC	VAC	0 - 525	0	
12	Encoder Pulses/Rev.	P/R	600 - 19999	1024	
13	Absolute Maximum RPM	RPM	50 - 3000	1750	
14	Maximum Armature Current	%	0 - 300	250	
15	Encoder Feedback On	Logic	0 (OFF) - 1 (ON)	0 (OFF)	
16	Armature Voltage @ Maximum Speed	VDC	150 - 550	500	
17	Standby Field Current	%	10 - 100	25	
18	Field Regulator Response	RAD	1.0 - 10.0	5	
19	3 Second Motor Contactor Fault	Logic	0 (OFF) - 1 (ON)	0 (OFF)	
20	Use Self Tune	Logic	0 (OFF) - 1 (ON)	0 (OFF)	
21	Armature Current Response	RAD	100 - 750	250	
22	Speed Regulator Response	RAD	1.0 - 10.0	4	
23	System PU Inertia	SEC	0.25 - 15.00	2	
24	Speed Stability	PU	1.0 - 10.0	2	
26	Position Damping	PU	0.5 - 10.0	2	
27	Acceleration Time	Sec	0.5 - 15.0	5	
28	Deceleration Time	Sec	0.5 - 15.0	3	
29	Analog Source Select	Logic	0 (OFF) - 1 (ON)	0 (OFF)	
30	Speed Mode Select	# Select	1 - 3	1	
31	Preset Speed 1	%	0 - 50	10	
32	Preset Speed 2	%	0 - 150	20	
33	Preset Speed 3	%	0 - 150	30	
34	Preset Speed 4	%	0 - 150	40	
35	Preset Speed 5	%	0 - 150	50	
36	Preset Speed 6	%	0 - 150	60	
37	Preset Speed 7	%	0 - 10	5	
38	Micro -Speed 1 Gain	PU	0.00 - 1.00	1	
39	Micro -Speed 2 Gain	PU	0.00 - 1.00	1	
40	Start - Stop Mode	# Select	1 - 4	1	

Function #	Description	Units	Range	Default	User Value
41	Brake Release Timer	Sec	0.0 – 2.55	0.7	
42	Brake Set Timer	Sec	0.0 – 2.55	0.7	
43	Load Float Time	Sec	0 – 255	10	
44	Answer-Back Time	Sec	0.0 – 2.55	0.7	
45	Brake Slip Timer	Sec	0.0 – 25.5	5	
46	Maximum Brake Slip	Pulses	0 – 16536	250	
47	Brake Release Check Time	Sec	0.0 – 2.55	0.5	
48	Brake Release Movement	Pulses	0 – 16536	50	
49	Brake Fault Speed	%	0 – 150	10	
50	IFBK OK Timer	Sec	0.0 – 2.55	0.5	
51	Bipolar Analog Input T68	Logic	0 (OFF) – 1 (ON)	0 (OFF)	
52	Analog Input T68 Bias	PU	+/- 2.00	0	
53	Analog Input T68 Gain	PU	0.0 – 2.00	1	
55	Bipolar Analog Input T76	Logic	0 (OFF) – 1 (ON)	0 (OFF)	
57	Analog Input T76 Bias	PU	+/- 2.00	0	
58	Analog Input T76 Gain	PU	0.0 – 2.00	1	
60	Analog Output T45	# Select	0 – 6	1	
61	Analog Output T45 Bias	PU	+/- 1.00	0	
62	Analog Output T45 Gain	PU	0.0 – 10.00	0.8	
65	Analog Output T46	# Select	0 – 8	1	
66	Analog Output T46 Bias	PU	+/- 1.00	0	
67	Analog Output T46 Gain	PU	0.0 – 10.00	0.8	
71	Multi-Function Input T_9_Select	# Select	0 – 25	1	
72	Multi-Function Input T_10_Select	# Select	0 – 25	2	
73	Multi-Function Input T_11_Select	# Select	0 – 25	3	
74	Multi-Function Input T_12_Select	# Select	0 – 25	4	
75	Multi-Function Input T_50_Select	# Select	0 – 25	5	
76	Multi-Function Input T_51_Select	# Select	0 – 25	21	
77	Multi-Function Input T_52_Select	# Select	0 – 25	0	
78	Multi-Function Input T_53_Select	# Select	0 – 25	0	
79	Multi-Function Input T_54_Select	# Select	0 – 25	14	
81	K1_Logic_Out_Select	# Select	0 – 14	14	
82	K2_Logic_Out_Select	# Select	0 – 14	2	
83	K3_Logic_Out_Select	# Select	0 – 14	2	
84	K4_Logic_Out_Select	# Select	0 – 14	12	
85	K5_Logic_Out_Select	# Select	0 – 14	13	
86	K6_Logic_Out_Select	# Select	0 – 14	4	
87	K7_Logic_Out_Select	# Select	0 – 14	1	

Function #	Description	Units	Range	Default	User Value
90	Full Field Detect	%	50 – 95	90	
91	Zero Speed Threshold	%	.01 – 5	1	
92	Inch Timer	Sec	0 – 15	2	
93	Torque Decay Time	Sec	0.01 – 2.5	0.2	
94	Overspeed Trip	%	0 – 150	110	
95	Encoder Sense Voltage	%	0 – 100	25	
96	Encoder Sense Speed	%	0 – 100	5	
98	Motor Overload Current	PU	0.5 – 2	1.15	
99	Motor Overload Time	Sec	2 – 500	48	
100	Initial Starting Torque	%	0 – 100	100	
101	Minimum Starting Torque	%	0 – 100	10	
102	Regen Margin	PU	1.0 – 2.0	1.2	
103	Down Starting Current Limit	%	0 – 100	10	
104	Torque Regulator Gain	PU	- 10 – 10	0	
110	Ultra Lift Mode	# Select	0 – 2	0	
111	Ultra Lift Threshold Speed	%	20 – 150	100	
112	Ultra Lift Maximum Speed	%	25 – 150	100	
113	Ultra Lift Maximum Current	%	50 – 100	50	
114	Ultra Check Time	Sec	0 – 30	2	
120	Protocol Select	# Select	0 – 1	0	
121	Modbus Baud Rate	# Select	0 – 2	1	
122	Modbus Address	NUM	1 – 31	1	
123	Modbus Parity	# Select	0 – 1	0	
124	Modbus Communication Timeout	Sec	0.005 – 10	0.250	
199	Error List Reset	Logic	0 – 1	0	