

IMPULSE·VG+ *Series 4*

Adjustable Frequency/Vector Crane Controls

Product Features and Specifications



MAGNETEK
MATERIAL HANDLING

August 2011
© Copyright 2011 Magnetek



IMPULSE VG+ Crane and Hoist Features

Feature	Benefit
Safe Operating Windows	Reduces the possibility of programming unsafe parameters
X-Press Programming™	Allows programming of the initial setup in seconds
Multi-Level Password Protection	Limits unauthorized modification of drive parameters
Quick Stop™	Reduces the possibility of load and crane collision
Reverse Plug Simulation™	Allows the operator to smoothly and quickly stop and change directions without setting the parking brake
Micro-Positioning™	Allows the operator to make precise, slow movements to position a load
Load Check II™	Prevents lifting an overload
Ultra-Lift™	Allows overspeeding with light loads or an empty hook
Inching Control	Allows the ability to control the amount of time the crane will run to position load
Phase Loss Detection	In case of output phase loss, the brake will set immediately, retaining the load
Control Interface	Optically isolated quick disconnect 120 VAC control interface with parameter backup (24 VDC, 24 VAC, and 48 VAC optional)
Automatic Reset	Allows selectable conditions to be automatically reset with a new run command
Brake Test	Allows testing of available brake torque
Encoder Loss Detection	Signal loss detection at all times, even when the motor is not rotating (load float)
Roll Back Detection/Torque Proving at Start/Brake Check at Stop	The drive monitors brake functionality and motor torque at start and stop; the drive will maintain control of the load in case of a brake failure
Slack Cable Detection	Provides annunciation of the slack cable condition to the operator
Snapped Shaft Detection	Detects a broken coupling shaft or discontinuity in the drive train
Indexing	Allows precise programmed motor movement
Load Sharing	Allows two or more mechanically coupled motors to be controlled in a master/slave torque control fashion
Hook Height Measurement	Uses an incremental encoder signal to determine hook height from the calibrated position
Electronic Programmable Limit Switch	Allows slow down and stop limits without a geared limit switch
Load Float™	Allows a load to be held aloft at zero speed without setting the electric brake
Weight Calculation	Enables load weight to be calculated with an accuracy of ±5% of the full load (0–10 VDC Output)



IMPULSE VG+ Standard Features

Feature	Benefit
Over-Torque/Under-Torque Detection	Allows programmable outputs and actions based on torque conditions
Slip Compensation	Automatically compensates for motor slip
Motor Lead Reversal	Electronically swaps motor leads for reverse operation
Keypad Copy	Copy, store and write parameters from keypad
Safe Torque Off	Provides a redundant hardware safety circuit that guarantees motor and brake power are removed when an E-STOP switch or safety controller opens the drive input, eliminating the need for external disconnects. This functionality is provided in a safety category 3 architecture, and designed to PLd and SIL CL2 according to ISO/EN 13849-1 and IEC/EN 62061 respectively, meeting the requirements of IEC/EN 61508.
Ground Fault	Short Circuit Protection reduces damage to motor and drive
Charge Lamp	Charge Indicator indicates when the DC BUS has discharged to a safe level
Communication	Built-in RS-485 communication (Modbus - RTU)
Static Auto Tune	Allows auto tune without mechanical disconnection
Enhanced Keypad Display	Easily navigate and read diagnostics
Stall Prevention	Extends acceleration time and prevents the motor torque limits from being exceeded
Multi-Function Input Terminals Set end of travel/slow down limits or other functions	Flash Memory stores the last ten fault occurrences, even after power-down, for diagnostic purposes
Elapsed Time Counter	Indicates actual time of operation (power on or run time)
Modbus RTU	Network communications

IMPULSE VG+ Option Cards

Option Name	Model Number
Ethernet/IP	SI-EN3
Modbus TCP/IP	SI-EM3
Profibus DP	SI-P3
Line Driver Encoder PG	PG-X3
Analog Input	AI-A3
Analog Output	AO-A3
Digital Input	DI-A3
Digital Output	DO-A3
AC Digital Input	S4I-120A60, S4I-48A60, S4I-24A60
AC Digital Input/Output	S4IO-120A60, S4IO-48A60, S4IO-24A60



IMPULSE VG+ Specifications

Certification	UL, cUL, CSA (CE available upon request)
Rated input power supply volts	3-phase 200–240 VAC, 380–480 VAC, or 500-600 VAC; 50 or 60 Hz and frequency
Allowable input voltage fluctuation	+10% or -15% of nominal, 3-phase
Allowable input frequency fluctuation	±5% of nominal
Control method	Fully digital; sine-wave, V/F control, open loop vector control, flux vector control
Maximum output voltage (Vac)	Max output voltage 3-phase, 200/208/230/240/380/400/415/440/460/480 500/575/600V (proportional to input voltage)
Rated output frequency (Hz)	0 to 150 Hz (consult factory for applications above 150 Hz)
Output frequency accuracy	0.01% — with digital reference command, -10° to 40°C; 0.1% — with analog reference command; 10 bits/10V; 25°C, ±10°C
Frequency reference resolution	Digital: 0.01 Hz; analog: 0.03 Hz (at 60 Hz)
Output frequency resolution	0.01 Hz
Overload capacity	150% of rated load for 1 minute
Remote frequency reference sources	0–10 VDC (20W); 4–20 mA (250W); ±10 VDC; serial(RS-485)
Acceleration/deceleration times	0.1 to 25.5 sec — 4 sets; 8 parameters are independently adjustable
Braking torque	150% or more with dynamic braking (optional)
Motor overload protection	Electronic thermal overload relay; UL recognized (I2T)
Overcurrent protection level (OC)	200% of drive rated current
Circuit protection	Ground fault and blown-fuse protection
Overvoltage protection level	410 VDC (200V), 820 VDC (400V), 1040 VDC (600V)
Undervoltage protection level	190 VDC (200V), 380 VDC (400V), 475 VDC (600V)
Heatsink over temperature	Thermostat trips at 105°C
Four quadrant torque limit selection	Separate functions for FORWARD, REVERSE, REGEN; all selectable from 0–300%
Stall prevention	Separate functions for acceleration, at-speed and constant horsepower region
Other protection features	Speed deviation, overspeed, mechanical brake failure, lost output phase, lost input phase, failed-oscillator, PG-disconnect, mechanical overload, roll-back detection, internal braking transistor failure, and built in watchdog
DC bus voltage indication	Charge LED is on until DC bus voltage drops below 50 VDC
Environment	Indoors; requires protection from moisture, corrosive gases and liquids
Ambient operating temperature	14° to 140°F (-10° to 60°C). Consult factory for high ambient applications
Storage temperature	-4° to 158°F (-20° to 70°C)
Humidity	95% relative; non-condensing
Vibration	1 G for 10-20 Hz 0.6 G for 20-55 Hz (2003-2180, 4001-4150, 5001-5077) 0.2 G for 20-55 Hz (2215-2415, 4180-41090. 5099-5200)
Elevation	3300 ft. (1000m) or less 9900 ft. (3000m) or less with current derating
Safety Standard	UL 508C



Dimensions and Drive Ratings

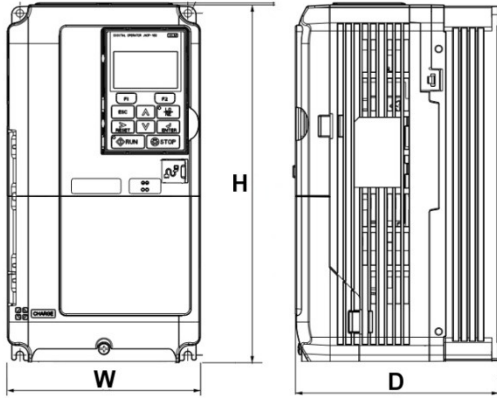

Figure 1

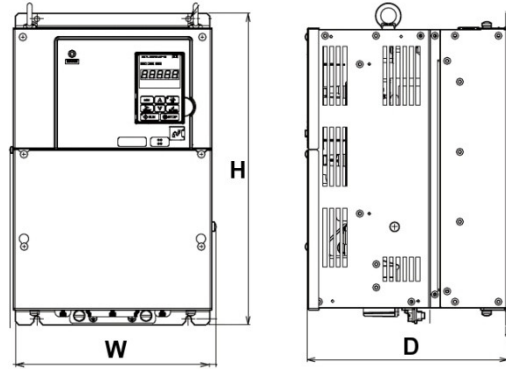

Figure 2

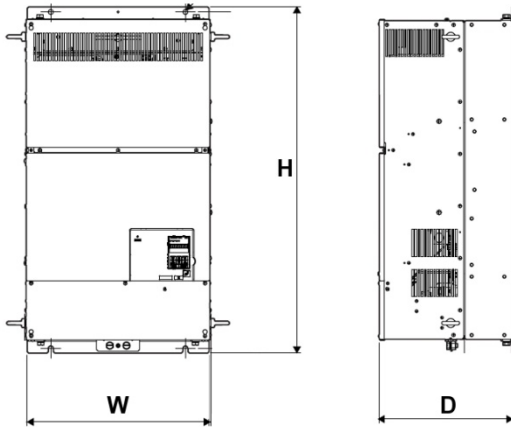

Figure 3

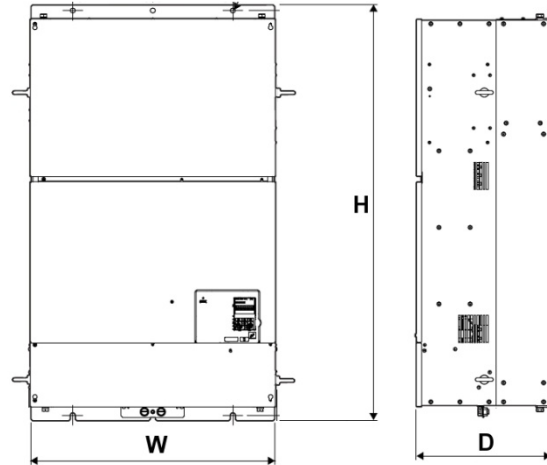

Figure 4



230V Drive Class

NEC HD HP	Model xxxx-VG+S4	Figure	H (in)	W (in)	D (in)	Wt (lbs)	Rated Amps (A)	Heat Loss (W)			
0.75	2003	1	10.24	5.51	5.79	7.3	3.2	59			
1	2005						5.0	72			
1	2007					6.9	84				
2	2008					8.0	95				
2	2011				6.46	8.2	11.0	122			
3	2014						14.0	137			
3	2017				6.57	9.3	17.5	168			
5	2025						25	287			
7.5	2033				11.81	7.09	7.36	13.0	33	319	
10	2047								47	410	
15	2060				13.78	8.66	7.76	20.1	60	558	
20	2075								75	681	
30	2085				2	21.02	10.00	10.16	50.7	85	721
40	2115					24.17	10.98		61.7	115	912
50	2145	28.74	12.95	11.14		90.4	145	1122			
60	2180					92.6	180	1354			
75	2215	27.76	17.72	12.99		167.6	215	1980			
100	2283					176.4	283	2524			
125	2346	31.50	19.69	13.78		216.1	346	3347			
150	2415					218.3	415	3626			



460V Drive Class

NEC HD HP	Model xxxx-VG+S4	Figure	H (in)	W (in)	D (in)	Wt (lbs)	Rated Amps (A)	Heat Loss (W)
0.75	4001	1	10.24	5.51	5.79	7.5	1.8	61
1	4003						3.4	70
2	4004						4.8	87
3	4005				6.46	7.9	5.5	101
5	4007					7.2	108	
5	4009				8.2	9.2	130	
10	4014		6.57	9.0	14.8	221		
10	4018				18.0	247		
15	4024		11.81	7.09	12.6	24	323	
20	4031				7.36	13.2	31	403
30	4039				7.76	19.2	39	509
30	4045		2	18.31	10.00	10.16	50.7	45
40	4060	20.28		10.98	59.5		60	701
60	4075	24.80		12.95	86.0		75	817
75	4091					91	1022	
75	4112	28.74		11.14	99.2	112	1325	
125	4150				101.4	150	1920	
150	4180	27.76		17.72	12.99	174.2	180	2313
150	4216	31.50		19.69	13.78	211.6	216	3075
200	4260					224.9	260	3178
250	4304				235.9	304	4060	
300	4370	3		37.40	14.57	275.6	370	4742
350	4450	4		44.88		476.2	450	5358
500	4605		487.2			605	5875	



575V Drive Class

NEC HD HP	Model xxxx-VG+S4	Figure	H (in)	W (in)	D (in)	Wt (lbs)	Rated Amps (A)	Heat Loss (W)	
1	5001	1	10.24	5.51	5.79	7.5	1.7	48.7	
2	5003				3.5		81.9		
3	5004				6.46	8.2	4.1	80.0	
5	5006						6.3	115.1	
7.5	5009						6.57	9.0	9.8
10	5012		11.81	7.09	7.36	13.2	12.5	212.2	
15	5017		2	13.78	8.66	7.76	19.2	17	284.8
20	5022							22	381.1
25	5027			20.28	10.98	10.16	59.5	27	465.1
30	5032							32	533.5
40	5041	28.74		12.95	11.14	99.2	41	688.5	
50	5052						52	1606.5	
60	5062						62	1836.5	
75	5077						77	1619.0	
100	5099	27.76	17.72	12.99	174.2	99	1750		
125	5130	27.76	17.72	12.99		130	2146		
150	5172	31.50	19.69	13.78	235.9	172	2762		
200	5200	31.50	19.69	13.78		200	3422		



Wiring Diagram

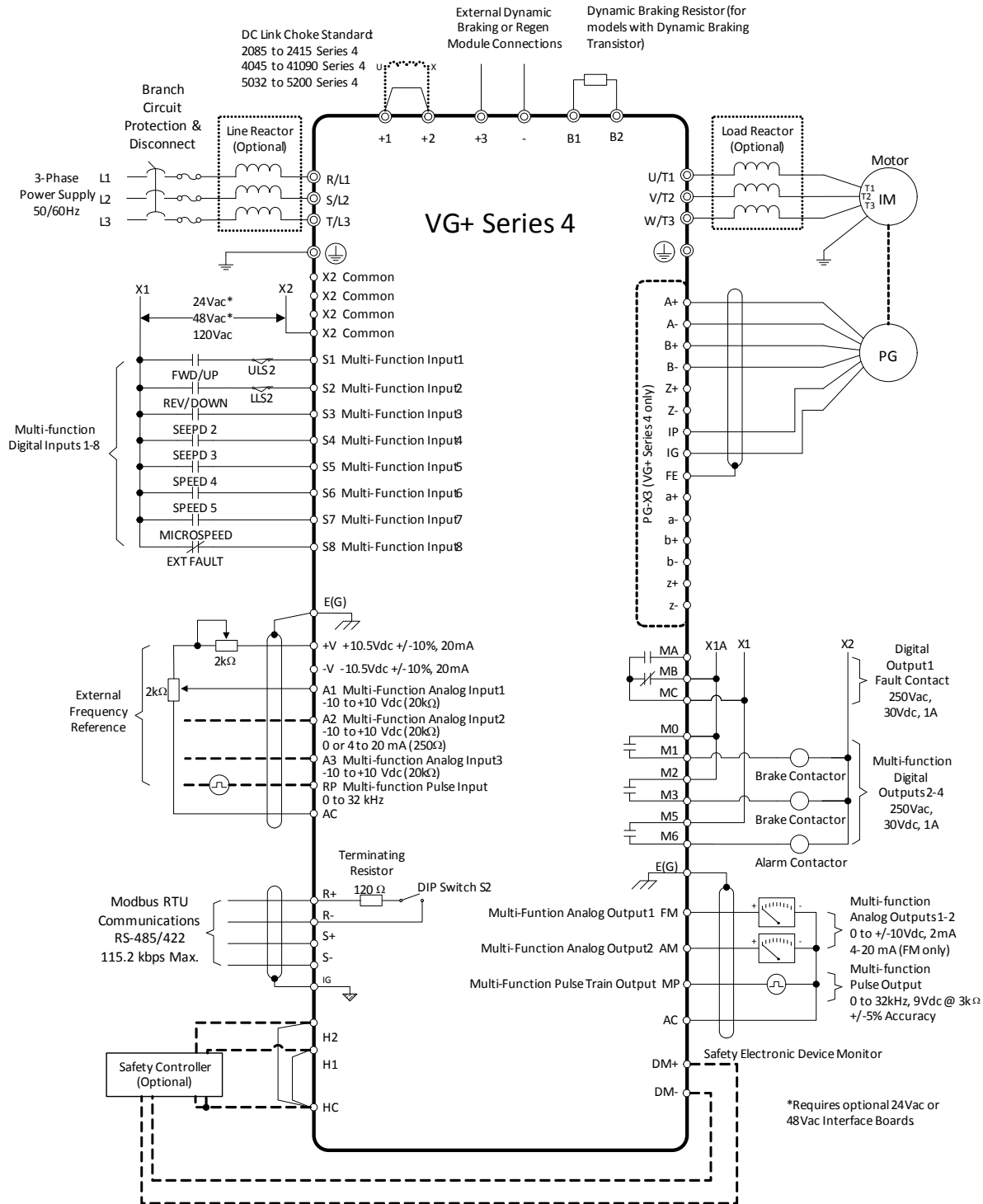

Figure 5