

Flex I-Chip

Remote Crane Controls



MAGNETEK
MATERIAL HANDLING
TELEMOTIVE

August 2010

Part Number: 198-50014

© 2010 Magnetek Material Handling

U.S. Service Information

For questions regarding service or technical information contact:

1.866.MAG.SERV

(1.866.624.7378).

Magnetek Material Handling
N49 W13650 Campbell Drive
Menomonee Falls, WI 53051

Telephone: 800.288.8178

Website: www.magnetekmh.com

e-mail: info@magnetekmh.com

Fax Numbers:

Main: 800.298.3503

Sales: 262.783.3510

Service: 262.783.3508

Canada Service Information:

2610 Dunwin Drive
Mississauga, Ontario
L5L 1J5 Canada
Phone: 1.800.792.7253
Fax: 1.905.828.5707

©2009 MAGNETEK MATERIAL HANDLING

All rights reserved. This notice applies to all copyrighted materials included with this product, including, but not limited to, this manual and software embodied within the product. This manual is intended for the sole use of the person(s) to whom it was provided, and any unauthorized distribution of the manual or dispersal of its contents is strictly forbidden. This manual may not be reproduced in whole or in part by any means whatsoever without the expressed written permission of MAGNETEK.

PRODUCT MANUAL SAFETY INFORMATION

Magnetek, Inc. (Magnetek) offers a broad range of radio remote control products, control products and adjustable frequency drives, and industrial braking systems for overhead material handling applications. This manual has been prepared by Magnetek to provide information and recommendations for the installation, use, operation and service of Magnetek's material handling products and systems (Magnetek Products). Anyone who uses, operates, maintains, services, installs or owns Magnetek Products should know, understand and follow our instructions and safety recommendations in this manual for Magnetek Products.

The recommendations in this manual do not take precedence over any of the following requirements relating to cranes, hoists and lifting devices:

- Instructions, manuals, and safety warnings of the manufacturers of the equipment where the radio system is used,
- Plant safety rules and procedures of the employers and the owners of facilities where the Magnetek Products are being used,
- Regulations issued by the Occupational Health and Safety Administration (OSHA),
- Applicable local, state or federal codes, ordinances, standards and requirements, or
- Safety standards and practices for the overhead material handling industry.

This manual does not include or address the specific instructions and safety warnings of these manufacturers or any of the other requirements listed above. It is the responsibility of the owners, users and operators of the Magnetek Products to know, understand and follow all of these requirements. It is the responsibility of the owner of the Magnetek Products to make its employees aware of all of the above listed requirements and to make certain that all operators are properly trained. **No one should use Magnetek Products prior to becoming familiar with and being trained in these requirements.**

WARRANTY INFORMATION

FOR INFORMATION ON MAGNETEK'S PRODUCT WARRANTIES BY PRODUCT TYPE, PLEASE VISIT WWW.MAGNETEKMH.COM.

Table of Contents

A.	Exterior Illustrations	5
B.	Testing Complete Transmitter	6
C.	Testing Encoder Board	7
D.	Testing Receiving Module	9
E.	Decoder Module Programming	10
F.	I-Chip programming	11
1.	LCD and keypad illustrations	11
2.	Copy I-Chip	11
3.	Program System Serial Number	12
4.	Program System Type	12
5.	Program Start/Aux Function	12
6.	Program Transmitter Output Power	13
7.	Program Transmitter On Time / Transmitting Time	13
8.	Program System RF Channel	13
9.	Program Transmitter Push Button Functions	13
Table A-1.	Transmitter Toggle with LED Displays	14
Table A-2.	Inline Transmitter Toggle with LED Displays	14
Table B-1.	A/B Push Button Select	16
Table B-2.	Inline A/B Push Button Select	19
Table C-1.	Combination of Transmitter Toggle + A/B Push Button Select	23
Table C-2.	Combination of Transmitter Toggle + A/B Push Button Select	26
10.	BRAKE Function (not required if programmed directly on the decoder module - Section E)	27
11.	PASSWORD / Security Code Function	27

A. Exterior Illustrations

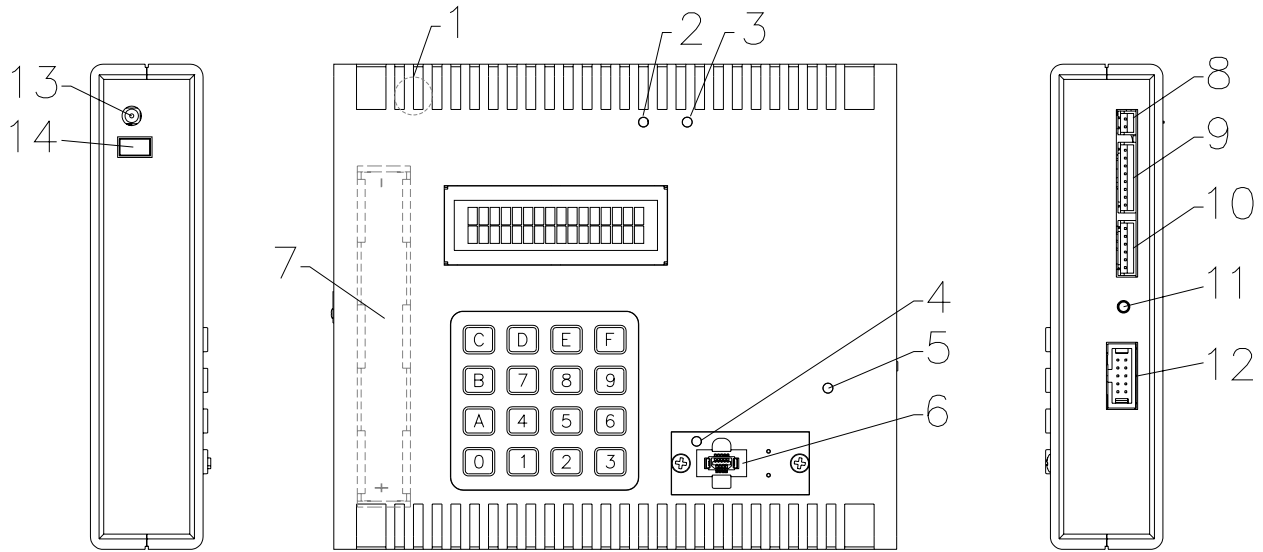

- | | |
|--|--|
| 1) Fuse (1.0A) | 8) Power cable to encoder board |
| 2) Power LED | 9) Cable to encoder board's CN1 connector |
| 3) SQ1 LED (internal receiving module) | 10) Cable to I-Chip slot on decoder modules |
| 4) I-Chip LED | 11) Test mode select button |
| 5) SQ2 LED (external receiving module) | 12) External receiving module input slot |
| 6) I-Chip slot | 13) External power input slot (not provided) |
| 7) Internal battery compartment | 14) Power switch |

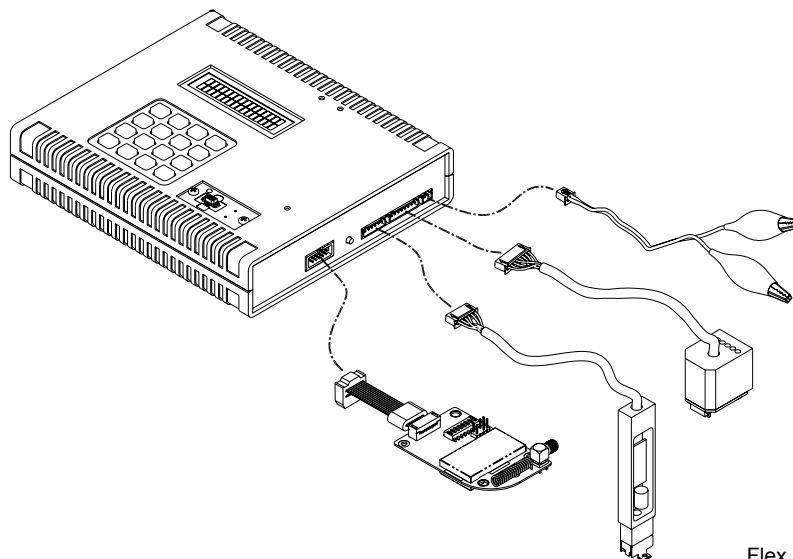

B. Testing Complete Transmitter

To check if the transmitter handset is in good order please follow the instruction below.

- 1) Press the Test Mode Select button until the LCD screen displays "Testing Complete Transmitter 1".

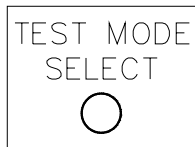

- 2) The LCD screen is displayed as follows:

Testing Complete Transmitter

S - - - - -	T - -	M - -	CH 01
↓	↓	↓	↓
Serial number	Type	Mode	Channel

- 3) First set this unit's channel identical to the one set on the transmitter handset to be tested via the ↑ & ↓ push buttons on the keypad.
- 4) Turn on the transmitter and rotate the power key to Start position.
- 5) At this time the SQ1 LED should blink red with the transmitter information displayed on the LCD screen. If SQ1 LED does blink red but does not have the transmitter information shown on the LCD screen then the encoder board is defective. If nothing is shown at all (both SQ1 LED and transmitter information), then either the internal transmitting board or the encoder board is defective. If this is the case, then proceed to section C to check the transmitting board and encoder board.
- 6) If SQ1 LED does blink red with the transmitter information shown on the LCD screen then go on to check all the push button commands.
- 7) Press all the push buttons on the transmitter, one at a time, to check if this unit decodes all the pushbutton commands. When a push button is pressed, an arrow should appear below the system information, for both 1st and 2nd steps. If not, then the encoder board is defective. If only one or two push buttons do not display the arrows on the LCD screen when pressed, then those push buttons are defective.
- 8) If all the information is correct then the transmitter handset is in good order. Go on to section D to check

the receiving module.

C. Testing Encoder Board

To check if the encoder boards is in good order please follow the instructions below.

- 1) Press the Test Mode Select button until the LCD screen displays "Testing Encoder Board 5".

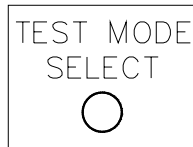

- 2) The LCD screen is displayed as follows:

Testing Encoder Board

S - - - - -	T - -	M - -
↓	↓	↓
Serial number	Type	Mode

- 3) Plug all the required cables onto this unit

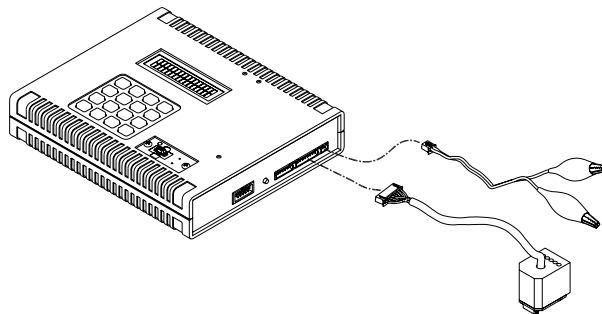

- 4) Plug all the cables from this unit to the encoder board.

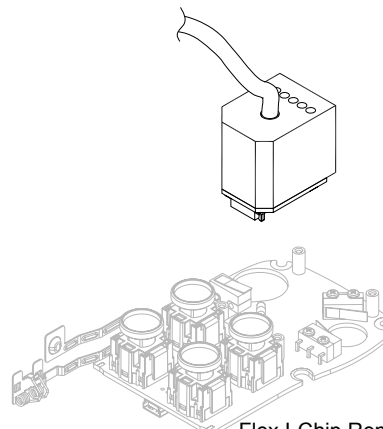
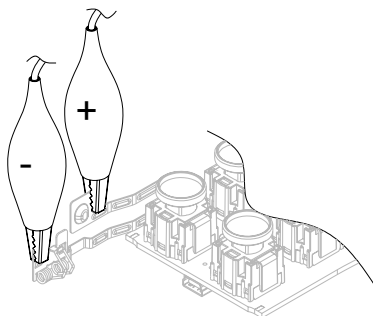

- 5) Make sure the encoder board has an I-Chip installed.
- 6) Press and hold on to the power switch.

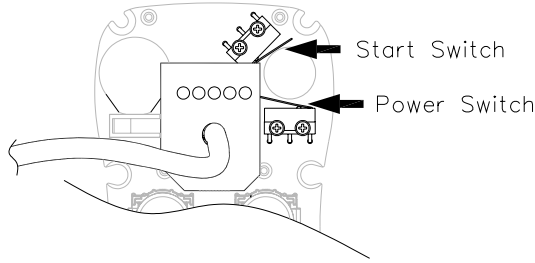

- 7) Press the Start micro switch one time and let go. The LED 1 should blink green.

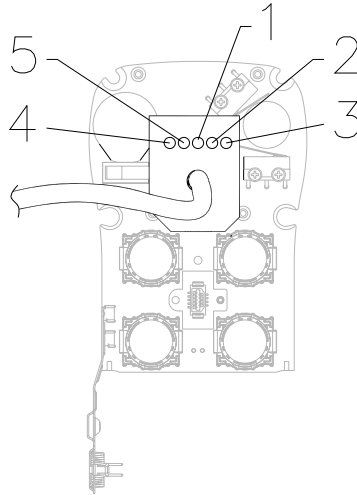

- 8) At this time the LCD screen should display the transmitter I-Chip information. If not, then the encoder board is defective.
- 9) If the LCD screen does display transmitter information correctly, then press all the push buttons on the encoder board one at a time to see if the unit decodes all the pushbutton commands. When a push button is pressed, an arrow should appear below the system information displays, for both 1st and 2nd steps. If not, then the encoder board is defective. If only one or two push buttons do not display the arrows on the LCD screen when pressed, then those push buttons are defective.
- 10) If all the information is correct then the encoder board is in good order. If this is the case, then the transmitting board is defective.

D. Testing Receiving Module

To check if the receiving module is in good order please follow the instructions below.

- 1) Press the Test Mode Select button until the LCD screen displays "Testing Receiver Module 2".

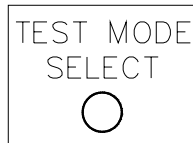

- 2) The LCD screen is displayed as follows:

Testing Receiving Module

S - - - - -	T - -	M - -
↓	↓	↓
Serial number	Type	Mode

- 3) Plug the receiving module to be tested on to this unit.

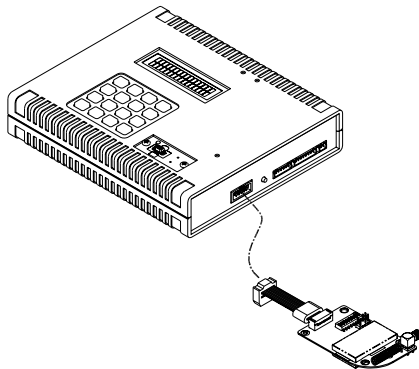

- 4) Use a good transmitter handset (any type) to test the receiving module.
- 5) Set the channel dip switch on the receiving module to the one set on the transmitter.
- 6) Turn the transmitter power on and rotate the power key to the Start position. The SQ2 LED should light up or blink; if not, then the receiving module is defective.
- 7) If SQ2 LED blinks red with all the transmitter information shown on the LCD screen then the decoder module is defective.

E. Decoder Module Programming

You can program the serial number, system type, Start/Aux, brake function and service date onto the decoder module.

- 1) Plug all the required cables onto this unit.

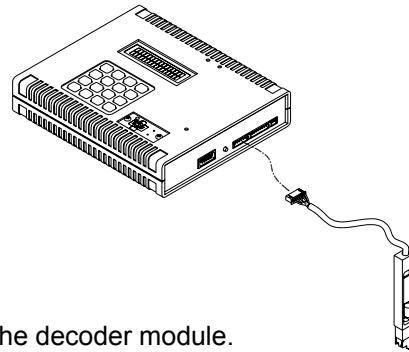

- 2) Plug the cable from this unit to the I-Chip slot on the decoder module.

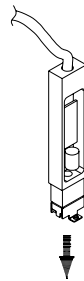

- 3) Press the Test Mode Select button until the LCD screen displays "Decoder Programming 4".

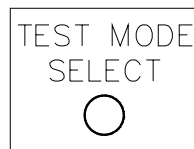

- 4) Set the serial number, system type, Start/Aux and brake function by using Next, Previous, ↑ & ↓ arrows and keypad. Press Copy button when done.

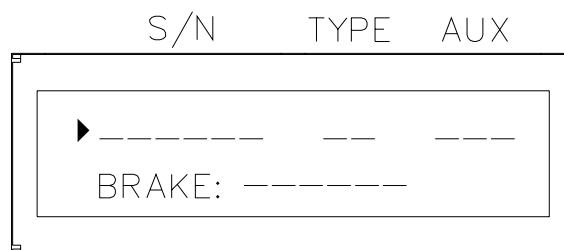

- 5) Scroll down to the next screen by pressing the Next button. The production and service date information will appear. Only the service date can be reprogrammed.

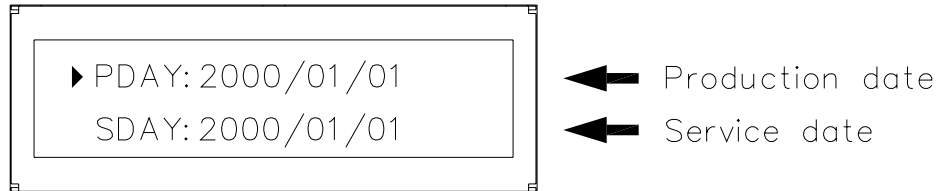

F. I-Chip programming

Press the Test Mode Select button until the LCD screen displays "I-Chip Programming 3".

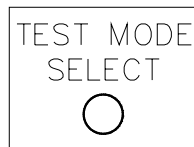

1. LCD and keypad illustrations

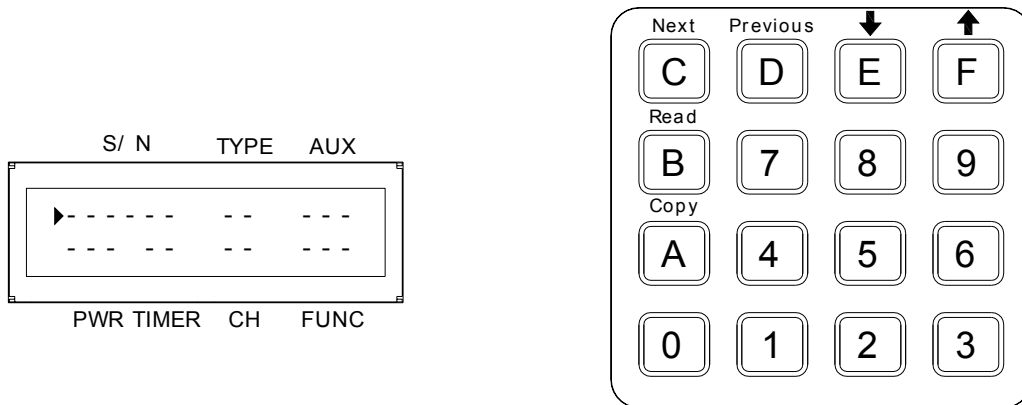

2. Copy I-Chip

If you do not have an empty I-Chip on hand, you can store the original I-Chip's information into the programmer unit temporarily and perform a copy at later time.

Steps: First insert the original I-Chip onto the I-Chip slot, press READ button to store original I-Chip information into the programmer unit (red light will appear on the I-Chip LED then green again), insert an empty I-Chip onto the same I-Chip slot, press the COPY button to transfer information from the programmer unit to the empty I-Chip (red light will appear on the I-Chip LED, then turn green again). This will complete the programming.

3. Program System Serial Number

Change the system's serial number simply by moving the black arrow on the LCD screen to the **S/N** location via NEXT and PREVIOUS button, then either press the ↑ & ↓ arrows or the number buttons directly to change the serial number.

When finished, take the same I-Chip and insert it onto the I-Chip programming port (located on the decoder module) to transfer the serial number from the I-Chip to the receiver. To transfer I-Chip information to the receiver, JP6 must be inserted (not required if programmed directly on the decoder module – Section E).

4. Program System Type

Change the system type simply by moving the black arrow on the LCD screen to the **TYPE** location via NEXT and PREVIOUS button, then press the ↑ & ↓ arrows to change value. For standard systems, always set the value at "00". For tandem transmitters, you must set tandem transmitter-A to "01" value and tandem transmitter-B to "02" value.

When finished, take the same I-Chip and insert it onto the I-Chip programming port (located on the decoder module) to transfer the Tandem function to the receiver (transmitter-A to receiver-A and transmitter-B to receiver-B). To transfer I-Chip information to the receiver, JP6 must be inserted (not required if programmed directly on the decoder module – Section E).

5. Program Start/Aux Function

(not required if programmed directly on the decoder module - Section E)

After initiating the START function, the same location will then become an AUX function. You can set the FUNCTION relay in the receiver, when rotate to START position, the relay will close momentarily, toggled or toggled affected by E-Stop activation. When set with the START/AUX function, the external warning function is no longer available. Add the START/AUX function simply by moving the black arrow on the LCD screen to the **AUX** location via NEXT and PREVIOUS button, and then press the ↑ & ↓ arrows to change value.

- : **START function only, no AUX function thereafter.**
- NOR** : **START function + AUX with normal momentary contact.**
- TOG** : **START function + AUX with toggled/latching contact.**
- T/E** : **START function + AUX with toggled/latching contact affected by the E-Stop button (FUNCTION relay will open when e-stop button is pressed down)**
- EXT** : **FUNCTION relay works simultaneously with receiver MAIN.**

When finished, take the same I-Chip and insert it onto the I-Chip programming port (located on the decoder module) to transfer the START/AUX function to the receiver. To transfer I-Chip information

to the receiver, JP6 must be inserted (not required if programmed directly on the decoder module – Section E).

6. Program Transmitter Output Power

Change transmitter output power simply by moving the black arrow on the LCD screen to the **PWR** location via NEXT and PREVIOUS button, then press ↑ & ↓ arrows to change the output power. “-23” value will give you the shortest transmitting range but longest battery life while “+12” value will give you the longest transmitting range but shortest battery life. We recommend that for indoor applications, the transmitter output power should be set from “-5” to “+3” value. For outdoor applications, we recommend that you set the transmitter output power from “+6” to “+10” value.

7. Program Transmitter On Time / Transmitting Time

Not applicable for FCC systems.

8. Program System RF Channel

Change the system channel simply by moving the black arrow on the LCD screen to the **CH** location via NEXT and PREVIOUS button, then either press the ↑ & ↓ arrows or the number buttons directly to change system channel.

9. Program Transmitter Push Button Functions

Program transmitter push button functions (transmitter toggle and select functions) simply by moving the black arrow on the LCD screen to the **FUNC** location via NEXT and PREVIOUS button, then either press the ↑ & ↓ arrows or the number buttons directly to set transmitter push button functions. The transmitter push button function tables on the following pages tell you which number value correspond to which push button function.

Table A-1. Transmitter Toggle with LED Displays

No	Dip-switch Setting	PB1	PB2	PB3	PB4	PB5	PB6	PB7	PB8	PB9	PB10	PB11	PB12
1	00000001				4								
2	00000010			3	4								
3	00000011		2	3	4								
4	00000100	1	2	3	4								
5	00000101								4				
6	00000110							3	4				
7	00000111						2	3	4				
8	00001000					1	2	3	4				
9	00001001										4		
10	00001010									3	4		
11	00001011								2	3	4		
12	00001100							1	2	3	4		
13	00001101												4
14	00001110											3	4
15	00001111										2	3	4
16	00010000									1	2	3	4

Table A-2. Inline Transmitter Toggle with LED Displays

No	Dip-switch Setting	PB1	PB2	PB3	PB4	PB5	PB6	PB7	PB8	PB9	PB10	PB11	PB12
1	00000001				4								
17	00010001			3	4								
18	00010010		2	3	4								
19	00010011	1	2	3	4								
5	00000101								4				
20	00010100							3	4				
21	00010101						2	3	4				
22	00010110					1	2	3	4				
5	00000101										4		
20	00010100									3	4		
21	00010101								2	3	4		

Table A-2. Inline Transmitter Toggle with LED Displays

No	Dip-switch Setting	PB1	PB2	PB3	PB4	PB5	PB6	PB7	PB8	PB9	PB10	PB11	PB12
22	00010110							1	2	3	4		
9	00001001											4	
23	00010111										3	4	
24	00011000									2	3	4	
25	00011001								1	2	3	4	
13	00001101												4
26	00011010											3	4
27	00011011										2	3	4
28	00011100									1	2	3	4

Table B-1. A/B Push Button Select													
Select Type A: A, B, A, B...													
Magnetek/Enrange Select Type A: A+B, A, B, A+B...													
Select Type B: Off, A, B, Off...													
Select Type C: A, B, A+B, A...													
Select Type D: Off, A, B, A+B, Off...													
No	Dip-switch Setting	PB1	PB2	PB3	PB4	PB5	PB6	PB7	PB8	PB9	PB10	PB11	PB12
29	00011101			A/1.2									
30	00011110			B/1.2									
31	00011111			C/1.2									
32	00100000			D/1.2									
33	00100001				A/3.4								
34	00100010				B/3.4								
35	00100011				C/3.4								
36	00100100				D/3.4								
37	00100101			A/1.2	A/3.4								
38	00100110			A/1.2	B/3.4								
39	00100111			A/1.2	C/3.4								
40	00101000			A/1.2	D/3.4								
41	00101001			B/1.2	B/3.4								
42	00101010			B/1.2	C/3.4								
43	00101011			B/1.2	D/3.4								
44	00101100			C/1.2	C/3.4								
45	00101101			C/1.2	D/3.4								
46	00101110			D/1.2	D/3.4								
47	00101111							A/1.2					
48	00110000							B/1.2					
49	00110001							C/1.2					
50	00110010							D/1.2					
51	00110011								A/3.4				
52	00110100								B/3.4				
53	00110101								C/3.4				
54	00110110								D/3.4				

Table B-1. A/B Push Button Select													
Select Type A: A, B, A, B...													
Magnetek/Enrange Select Type A: A+B, A, B, A+B...													
Select Type B: Off, A, B, Off...													
Select Type C: A, B, A+B, A...													
Select Type D: Off, A, B, A+B, Off...													
No	Dip-switch Setting	PB1	PB2	PB3	PB4	PB5	PB6	PB7	PB8	PB9	PB10	PB11	PB12
55	00110111							A/1.2	A/3.4				
56	00111000							A/1.2	B/3.4				
57	00111001							A/1.2	C/3.4				
58	00111010							A/1.2	D/3.4				
59	00111011							B/1.2	B/3.4				
60	00111100							B/1.2	C/3.4				
61	00111101							B/1.2	D/3.4				
62	00111110							C/1.2	C/3.4				
63	00111111							C/1.2	D/3.4				
64	01000000							D/1.2	D/3.4				
65	01000001									A/1.2			
66	01000010									B/1.2			
67	01000011									C/1.2			
68	01000100									D/1.2			
69	01000101										A/3.4		
70	01000110										B/3.4		
71	01000111										C/3.4		
72	01000111										D/3.4		
73	01001001									A/1.2	A/3.4		
74	01001010									A/1.2	B/3.4		
75	01001011									A/1.2	C/3.4		
76	01001100									A/1.2	D/3.4		
77	01001101									B/1.2	B/3.4		
78	01001110									B/1.2	C/3.4		
79	01001111									B/1.2	D/3.4		
80	01010000									C/1.2	C/3.4		
81	01010001									C/1.2	D/3.4		

Table B-1. A/B Push Button Select													
Select Type A: A, B, A, B...													
Magnetek/Enrange Select Type A: A+B, A, B, A+B...													
Select Type B: Off, A, B, Off...													
Select Type C: A, B, A+B, A...													
Select Type D: Off, A, B, A+B, Off...													
No	Dip-switch Setting	PB1	PB2	PB3	PB4	PB5	PB6	PB7	PB8	PB9	PB10	PB11	PB12
82	01010010									D/1.2	D/3.4		
83	01010011											A/1.2	
84	01010100											B/1.2	
85	01010101											C/1.2	
86	01010110											D/1.2	
87	01010111												A/3.4
88	01011000												B/3.4
89	01011001												C/3.4
90	01011010												D/3.4
91	01011011											A/1.2	A/3.4
92	01011100											A/1.2	B/3.4
93	01011101											A/1.2	C/3.4
94	01011110											A/1.2	D/3.4
95	01011111											B/1.2	B/3.4
96	01100000											B/1.2	C/3.4
97	01100001											B/1.2	D/3.4
98	01100010											C/1.2	C/3.4
99	01100011											C/1.2	D/3.4
100	01100100											D/1.2	D/3.4

Table B-2. Inline A/B Push Button Select

Select Type A: A, B, A, B...

Magnetek/Enrange Select Type A: A+B, A, B, A+B...

Select Type B: Off, A, B, Off...

Select Type C: A, B, A+B, A...

Select Type D: Off, A, B, A+B, Off...

No	Dip-switch Setting	PB1	PB2	PB3	PB4	PB5	PB6	PB7	PB8	PB9	PB10	PB11	PB12
101	01100101			A/1.2									
102	01100110			B/1.2									
103	01100111			C/1.2									
104	01101000			D/1.2									
33	00100001				A/3.4								
34	00100010				B/3.4								
35	00100011				C/3.4								
36	00100100				D/3.4								
105	01101001			A/1.2	A/3.4								
106	01101010			A/1.2	B/3.4								
107	01101011			A/1.2	C/3.4								
108	01101100			A/1.2	D/3.4								
109	01101101			B/1.2	B/3.4								
110	01101110			B/1.2	C/3.4								
111	01101111			B/1.2	D/3.4								
112	01110000			C/1.2	C/3.4								
113	01110001			C/1.2	D/3.4								
114	01110010			D/1.2	D/3.4								
115	01110011							A/1.2					
116	01110100							B/1.2					
117	01110101							C/1.2					
118	01110110							D/1.2					
51	00110011								A/3.4				
52	00110100								B/3.4				
53	00110101								C/3.4				
54	00110110								D/3.4				

Table B-2. Inline A/B Push Button Select

Select Type A: A, B, A, B...

Magnetek/Enrange Select Type A: A+B, A, B, A+B...

Select Type B: Off, A, B, Off...

Select Type C: A, B, A+B, A...

Select Type D: Off, A, B, A+B, Off...

No	Dip-switch Setting	PB1	PB2	PB3	PB4	PB5	PB6	PB7	PB8	PB9	PB10	PB11	PB12
119	01110111							A/1.2	A/3.4				
120	01111000							A/1.2	B/3.4				
121	01111001							A/1.2	C/3.4				
122	01111010							A/1.2	D/3.4				
123	01111011							B/1.2	B/3.4				
124	01111100							B/1.2	C/3.4				
125	01111101							B/1.2	D/3.4				
126	01111110							C/1.2	C/3.4				
127	01111111							C/1.2	D/3.4				
128	10000000							D/1.2	D/3.4				
115	01110011									A/1.2			
116	01110100									B/1.2			
117	01110101									C/1.2			
118	01110110									D/1.2			
51	00110011										A/3.4		
52	00110100										B/3.4		
53	00110101										C/3.4		
54	00110110										D/3.4		
119	01110111									A/1.2	A/3.4		
120	01111000									A/1.2	B/3.4		
121	01111001									A/1.2	C/3.4		
122	01111010									A/1.2	D/3.4		
123	01111011									B/1.2	B/3.4		
124	01111100									B/1.2	C/3.4		
125	01111101									B/1.2	D/3.4		
126	01111110									C/1.2	C/3.4		
127	01111111									C/1.2	D/3.4		

Table B-2. Inline A/B Push Button Select

Select Type A: A, B, A, B...

Magnetek/Enrange Select Type A: A+B, A, B, A+B...

Select Type B: Off, A, B, Off...

Select Type C: A, B, A+B, A...

Select Type D: Off, A, B, A+B, Off...

No	Dip-switch Setting	PB1	PB2	PB3	PB4	PB5	PB6	PB7	PB8	PB9	PB10	PB11	PB12
128	10000000									D/1.2	D/3.4		
129	10000001										A/1.2		
130	10000010										B/1.2		
131	10000011										C/1.2		
132	10000100										D/1.2		
69	01000101											A/3.4	
70	01000110											B/3.4	
71	01000111											C/3.4	
72	01001000											D/3.4	
133	10000101										A/1.2	A/3.4	
134	10000110										A/1.2	B/3.4	
135	10000111										A/1.2	C/3.4	
136	10001000										A/1.2	D/3.4	
137	10001001										B/1.2	B/3.4	
138	10001010										B/1.2	C/3.4	
139	10001011										B/1.2	D/3.4	
140	10001100										C/1.2	C/3.4	
141	10001101										C/1.2	D/3.4	
142	10001110										D/1.2	D/3.4	
143	10001111											A/1.2	
144	10010000											B/1.2	
145	10010001											C/1.2	
146	10010010											D/1.2	
87	01010111												A/3.4
88	01011000												B/3.4
89	01011001												C/3.4
90	01011010												D/3.4

Table B-2. Inline A/B Push Button Select													
Select Type A: A, B, A, B...													
Magnetek/Enrange Select Type A: A+B, A, B, A+B...													
Select Type B: Off, A, B, Off...													
Select Type C: A, B, A+B, A...													
Select Type D: Off, A, B, A+B, Off...													
No	Dip-switch Setting	PB1	PB2	PB3	PB4	PB5	PB6	PB7	PB8	PB9	PB10	PB11	PB12
147	10010011											A/1.2	A/3.4
148	10010100											A/1.2	B/3.4
149	10010101											A/1.2	C/3.4
150	10010110											A/1.2	D/3.4
151	10010111											B/1.2	B/3.4
152	10011000											B/1.2	C/3.4
153	10011001											B/1.2	D/3.4
154	10011010											C/1.2	C/3.4
155	10011011											C/1.2	D/3.4
156	10011100											D/1.2	D/3.4

Table C-1. Combination of Transmitter Toggle + A/B Push Button Select

No	Dip-switch Setting	PB1	PB2	PB3	PB4	PB5	PB6	PB7	PB8	PB9	PB10	PB11	PB12
157	10011100			1	A/3.4								
158	10011110			1	B/3.4								
159	10011111			1	C/3.4								
160	10100000			1	D/3.4								
161	10100001		1	2	A/3.4								
162	10100010		1	2	B/3.4								
163	10100011		1	2	C/3.4								
164	10100100		1	2	D/3.4								
165	10100101			A/1.2	4								
166	10100110			B/1.2	4								
167	10100111			C/1.2	4								
168	10101000			D/1.2	4								
169	10101001		3	A/1.2	4								
170	10101010		3	B/1.2	4								
171	10101011		3	C/1.2	4								
172	10101100		3	D/1.2	4								
173	10101101							1	A/3.4				
174	10101110							1	B/3.4				
175	10101111							1	C/3.4				
176	10110000							1	D/3.4				
177	10110001						1	2	A/3.4				
178	10110010						1	2	B/3.4				
179	10110011						1	2	C/3.4				
180	10110100						1	2	D/3.4				
181	10110101							A/1.2	4				
182	10110110							B/1.2	4				
183	10110111							C/1.2	4				
184	10111000							D/1.2	4				
185	10111001						3	A/1.2	4				
186	10111010						3	B/1.2	4				
187	10111011						3	C/1.2	4				

Table C-1. Combination of Transmitter Toggle + A/B Push Button Select

No	Dip-switch Setting	PB1	PB2	PB3	PB4	PB5	PB6	PB7	PB8	PB9	PB10	PB11	PB12
188	10111100						3	D/1.2	4				
189	10111101									1	A/3.4		
190	10111110									1	B/3.4		
191	10111111									1	C/3.4		
192	11000000									1	D/3.4		
193	11000001								1	2	A/3.4		
194	11000010								1	2	B/3.4		
195	11000011								1	2	C/3.4		
196	11000100								1	2	D/3.4		
197	11000101									A/1.2	4		
198	11000110									B/1.2	4		
199	11000111									C/1.2	4		
200	11001000									D/1.2	4		
201	11001001								3	A/1.2	4		
202	11001010								3	B/1.2	4		
203	11001011								3	C/1.2	4		
204	11001100								3	D/1.2	4		
205	11001101											1	A/3.4
206	11001110											1	B/3.4
207	11001111											1	C/3.4
208	11010000											1	D/3.4
209	11010001										1	2	A/3.4
210	11010010										1	2	B/3.4
211	11010011										1	2	C/3.4
212	11010100										1	2	D/3.4
213	11010101											A/1.2	4
214	11010110											B/1.2	4
215	11010111											C/1.2	4
216	11011000											D/1.2	4
217	11011001										3	A/1.2	4
218	11011010										3	B/1.2	4
219	11011011										3	C/1.2	4

Table C-1. Combination of Transmitter Toggle + A/B Push Button Select

No	Dip-switch Setting	PB1	PB2	PB3	PB4	PB5	PB6	PB7	PB8	PB9	PB10	PB11	PB12
220	11011100										3	D/1.2	4

Table C-2. Combination of Transmitter Toggle + A/B Push Button Select

No	Dip-switch Setting	PB1	PB2	PB3	PB4	PB5	PB6	PB7	PB8	PB9	PB10	PB11	PB12
221	11011101			1	A/3.4								
222	11011110			1	B/3.4								
223	11011111			1	C/3.4								
224	11100000			1	D/3.4								
225	11100001		1	2	A/3.4								
226	11100010		1	2	B/3.4								
227	11100011		1	2	C/3.4								
228	11100100		1	2	D/3.4								
229	11100101							1	A/3.4				
230	11100110							1	B/3.4				
231	11100111							1	C/3.4				
232	11101000							1	D/3.4				
233	11101001						1	2	A/3.4				
234	11101010						1	2	B/3.4				
235	11101011						1	2	C/3.4				
236	11110100						1	2	D/3.4				
229	11101101									1	A/3.4		
230	11101110									1	B/3.4		
231	11101111									1	C/3.4		
232	11110000									1	D/3.4		
233	11110001								1	2	A/3.4		
234	11110010								1	2	B/3.4		
235	11110011								1	2	C/3.4		
236	11110100								1	2	D/3.4		
237	11110101										1	A/3.4	
238	11110110										1	B/3.4	
239	11110111										1	C/3.4	
240	11111000									1	1	D/3.4	
241	11111001									1	2	A/3.4	
242	11111010									1	2	B/3.4	
243	11111011									1	2	C/3.4	

Table C-2. Combination of Transmitter Toggle + A/B Push Button Select													
No	Dip-switch Setting	PB1	PB2	PB3	PB4	PB5	PB6	PB7	PB8	PB9	PB10	PB11	PB12
244	11111100									1	2	D/3.4	
245	11110101											1	A/3.4
246	11110110											1	B/3.4
247	11110111											1	C/3.4
248	11111000											1	D/3.4
249	11111001										1	2	A/3.4
250	11111010										1	2	B/3.4
251	11111011										1	2	C/3.4
252	11111100										1	2	D/3.4

10. BRAKE Function (not required if programmed directly on the decoder module - Section E)

There are 3 different types of brake configurations made available: Demag 1, Demag 2 and P&H types.

Demag 1: When releasing the push button from 2nd speed up to 1st speed, 1st speed output relay will open for up to 1.0 second and then close again.

Demag 2: When push button is pressed down to the 2nd speed directly from neutral position (0 speed), 1st speed output relay will maintain closure for up to 0.4 second before 2nd speed output relay is closed. When releasing the push button from 2nd speed up to neutral position (0 speed), 1st speed output relay will maintain closure for up to 0.5 second before going to neutral (0 speed).

P&H: When releasing the push button from 2nd speed up to neutral position (0 speed), 1st speed output relay will maintain closure for up to 0.1 second before going to neutral (0 speed).

When finished, take the same I-Chip and insert it onto the I-Chip programming port (located on the decoder module) to transfer the START/AUX function to the receiver. To transfer I-Chip information to the receiver, JP6 must be inserted (not required if programmed directly on the decoder module – Section E).

11. PASSWORD / Security Code Function

Only push button #1 through #4 is used for the password function. “1” represents PB1, “2”

represents PB2, “3” represents PB3 and “4” represents PB4.

1 1 1 1 : Password function disabled (manufacture preset)

