

Wireless Radio Control Solutions for Equipment Movement and Operations

PRODUCT SPECIFICATION SHEET

FLEX 8EX SYSTEM

The Enrange Flex 8EX packaged radio control system provides a standard cost effective solution to the restrictive use of hard-wired cabling. The system comes as a complete package with mounting hardware, and a manual. The transmitter and receiver are designed to be used for indoor and outdoor applications. For more information or questions please contact your local Enrange representative.



Transmitter Specifications

Transmitter Size:	(L x W x D) 7.25 x 5.5" x 3" x 1.3"
Transmitter Weight:	9 ounces
Enclosure Material:	Glass reinforced nylon
Sealing:	Gasket - NEMA 4, IP-66
Power:	(2) AA alkaline batteries, +100 hours operation

Receiver Specifications

Receiver Size:	(L x W x D) 12" x 8.9" x 3.3"
Mounting Type:	Panel mount
Sealing:	NEMA 4, IP-66
Input Voltage:	110-460VAC @ 50/60Hz
Current Draw:	<500mA
Output Type:	20 mechanical relays, 10A @ 250VAC
Diagnostics:	LED lights for visual feedback
Security Codes:	+ 1 million standard codes, field selectable or software programmed

General Specifications

Operating Temperature:	-25 - +70 deg C (-13 to +160 deg F)
RF Type:	Microprocessor controlled, 433 MHz, 62 RF Channels
RF Power:	< 1mW standard, no license required (FCC Part 15)
Typical Range:	+300 feet maximum
Security Codes:	+ 1 million standard codes, field selectable

Features

- Removable power key on the transmitter
- Two step (speed) pushbuttons standard
- Over 150 field settable functions
- Pre-wired receiver with 6' cable
- Pitch & catch between 2 operators
- Direction and compass labels standard

Options

- Rechargeable battery and charger option
- Molded rubber transmitter guard, retractable belt strap
- Padded nylon transmitter case
- 96DB Horn / Siren device available



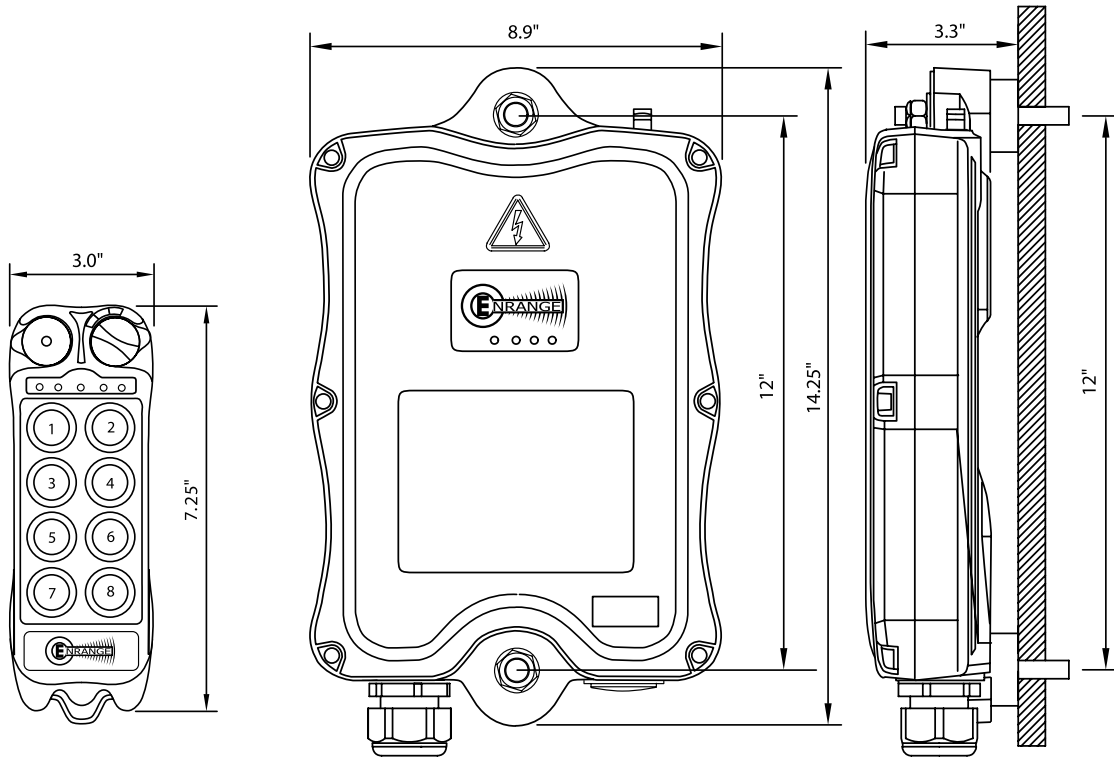

TYPICAL TRANSMITTER LAYOUT

TYPICAL RECEIVER LAYOUT

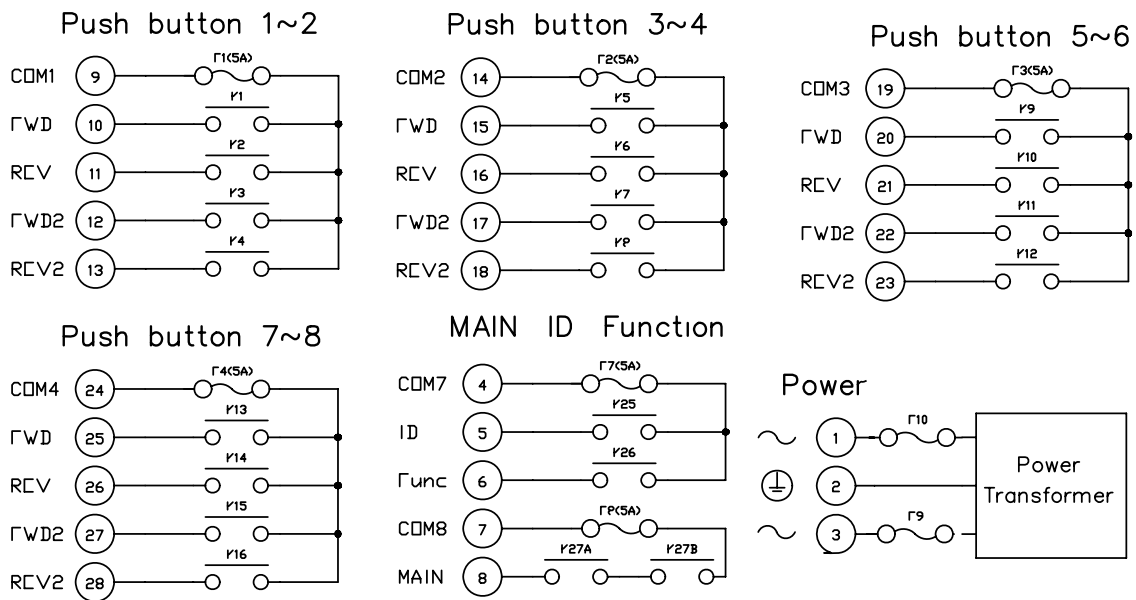

TYPICAL WIRING DIAGRAM



MAGNETEK
MATERIAL HANDLING

N49 W13650 Campbell Drive
Menomonee Falls, WI 53051
p 800.288.8178
f 262.783.3510

www.magnetekmh.com

2610 Dunwin Drive
Mississauga, Ontario
L5L 1J5 CANADA
p 800.792.7253
f 905.828.5707



#5 Four Coins Drive
Canonsburg, PA 15317-1751
p 724.746.3313
f 724.746.3379