

Wireless Radio Control Solutions for Equipment Movement and Operations

PRODUCT SPECIFICATION SHEET

700T TRANSMITTER

The model 700T transmitter is Enrange's most flexible configured radio transmitter. This durable beli-pak style transmitter with its low weight and long battery life is ideal for long shifts, and all day operation. The transmitter material and design makes it extremely durable for rugged environments. This unit is a semi-custom built to order unit offering our customers the most flexible transmitter arrangements. For more features and abilities custom configurations consult your local representative.



Specifications

| | |
|------------------------|---|
| Size: | (L x W x D) 11.5" x 6.9" x 7.1" |
| Weight: | ~ 4 pounds (varies with layout) |
| Enclosure Material: | Kydex |
| Sealing: | Gasket - NEMA 4, IP-65 |
| Operating Temperature: | -20 - +70 deg C (-18 to +160 deg F) |
| Power: | (6) AA alkaline batteries, or NIMH rechargeable |
| RF Type: | Microprocessor controlled PLL synthesizer, transceiver, 900 and 400MHz band available, multi-channel, 2.4GHz FHSS |
| RF Power: | < 1mW standard, no license required (FCC Part 15) |
| Typical Range: | +300 feet, adjustable distance, and +1500ft distance available |
| Security Codes: | +1 million standard codes, field selectable or software programmed |

Features

- Uses standard AA alkaline batteries
- Battery Life is +350 hours continuous operation for 1mW systems
- Automatic inactivity timeout, field settable
- Proportional and/or digital controls
- Large diameter buttons for gloved operators
- LCD display for operator feedback
- Very flexible, built to order transmitter

Options

- Single, or dual axis joysticks available
- Multiple trolley-hoist select, and crane select
- Universal spare transmitter
- Key switch lockout
- Feedback information for transceiver applications
- 20 Characters x 4 line LCD display
- Wired pendant/CAN bus backup
- Custom layouts available
- Custom programming available
- Custom labeling standard



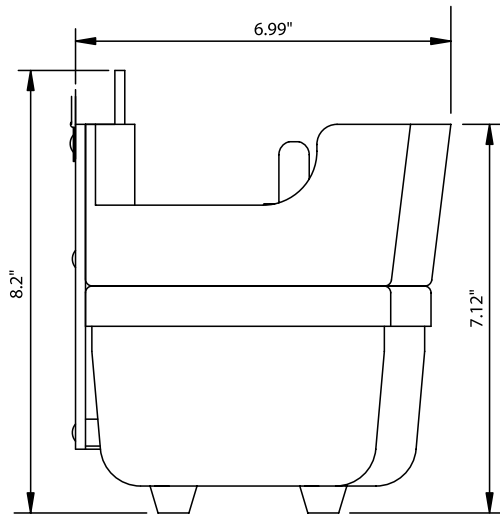
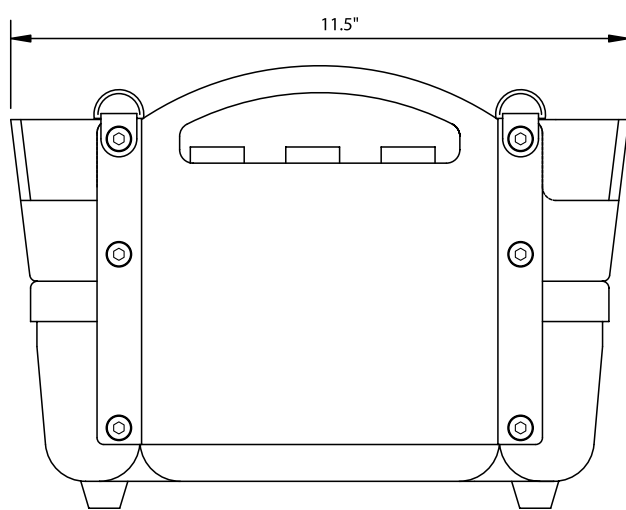
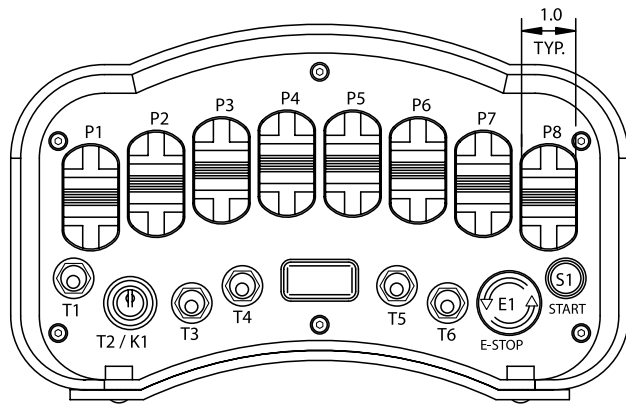

Notes:

1.) Due to the custom nature of this product, transmitter layouts can change. This unit shows 8 single axis paddles (maximum capacity) for multi-speed applications. Momentary or maintained toggle switches, keyswitches, and pushbutton switches all can be used. Call Enrange for details.

2.) The E-stop and Start switch are shown in standard locations. Positions may be relocated for custom applications.

- | | | | |
|-----------------------------|-------|---------------|--------------------------------------|
| Paddle P1: (variable speed) | _____ | Toggle T1: | _____ |
| Paddle P2: (variable speed) | _____ | Toggle T2: | _____ |
| Paddle P3: (variable speed) | _____ | Toggle T3: | _____ |
| Paddle P4: (variable speed) | _____ | Toggle T4: | _____ |
| Paddle P5: (variable speed) | _____ | Toggle T5: | _____ |
| Button P6: (variable speed) | _____ | Toggle T6: | _____ |
| Paddle P7: (variable speed) | _____ | Keyswitch K1: | _____ |
| Paddle P8: (variable speed) | _____ | E-STOP E1: | <u>standard emergency start</u> |
| | | START S1: | <u>standard START communications</u> |



MAGNETEK
MATERIAL HANDLING

N49 W13650 Campbell Drive
Menomonee Falls, WI 53051
p 800.288.8178
f 262.783.3510

www.magnetekmh.com

4090B Sladeview Crescent
Mississauga, Ontario
L5L 5Y5 CANADA
p 800.792.7253
f 905.828.5707



#5 Four Coins Drive
Canonsburg, PA 15317-1751
p 724.746.3313
f 724.746.3379