

©1999 ELECTROMOTIVE SYSTEMS, INC.

All rights reserved. This notice applies to all copyrighted materials included with this product, including, but not limited to, this manual and software embodied within the product. This manual is intended for the sole use of the persons to whom it was provided, and any unauthorized distribution of the manual or dispersal of its contents is strictly forbidden. This manual may not be reproduced in whole or in part by any means whatsoever without the expressed written permission of ELECTROMOTIVE SYSTEMS, INC.

## ***DANGER, WARNING, CAUTION, and NOTE* Statements**

*DANGER, WARNING, CAUTION, and Note* statements are used throughout this manual to emphasize important and critical information. You must read these statements to help ensure safety and to prevent product damage. The statements are defined below.



### **DANGER**

*DANGER* indicates an imminently hazardous situation which, if not avoided, will result in death or serious injury. This signal word is to be limited to the most extreme situations.



### **WARNING**

*WARNING* indicates a potentially hazardous situation which, if not avoided, could result in death or serious injury.



### **CAUTION**

*CAUTION* indicates a potentially hazardous situation which, if not avoided, could result in minor or moderate injury. It may also be used to alert against unsafe practices.

*NOTE:* A *NOTE* statement is used to notify people of installation, operation, programming, or maintenance information that is important, but not hazard-related.



## **WARNING**

- This manual instructs you how to use PulseStar•610. If you disregard the instructions, information, and/or warranty in the manual, you could be assuming responsibility for damages, costs, or injury incurred by such disregard.
- Do not touch any circuit components on the circuit board while the main AC or DC power is on.
- Do not make any address code or frequency channel changes in the transmitter or receiver without first contacting Electromotive Systems.

# Contents

Welcome! .....	vii
PulseStar•610 Components.....	viii
Receiver .....	viii
Transmitter .....	viii
How to Use This Manual .....	ix
Important System Information .....	ix

## Chapter 1: PulseStar•610 System Overview

PulseStar•610 System Overview .....	1-3
Introduction.....	1-3
Theory of Operation .....	1-3
Active Emergency Stop (E-STOP) Function .....	1-3
Sleep and Time-Out Modes.....	1-4
Transmitter Sleep Mode .....	1-4
Receiver Safe Mode .....	1-4

## Chapter 2: The PulseStar•610 Receiver

Overview .....	2-3
Receiver Components .....	2-4
Installing the PulseStar•610 Receiver.....	2-5
Assessing the Receiver Enclosure Environment .....	2-5
Serial Nameplate.....	2-5
Mounting the PulseStar•610 Receiver .....	2-6
Connecting a Standard External Antenna.....	2-7
Connecting a Gain Flex Antenna .....	2-8
Wiring the PulseStar•610 Receiver.....	2-9
Quick Disconnect Plug .....	2-9
Terminating Wires to the Quick Disconnect Plug .....	2-9
Quick Disconnect Plug Housing Orientation .....	2-10
Startup and Test Procedures .....	2-11

Pre-operation check list .....	2-11
Testing the Receiver .....	2-12
Changing the Frequency Channel of the Receiver .....	2-14
Standard RF Module .....	2-14
Scan RF Module .....	2-16
Setting the Scan Mode .....	2-17
Receiver Options .....	2-18
Range Limitation .....	2-18
Special Enclosures .....	2-18
Intrinsically Safe Systems .....	2-18
Marine Duty/Corrosion Resistant Systems .....	2-18

## **Chapter 3: The PulseStar•610 Transmitter**

Overview .....	3-3
PulseStar•610 Transmitters .....	3-4
JRT Transmitter .....	3-4
JRT Transmitter Components .....	3-4
JRT Transmitter Functions .....	3-5
PBT Transmitter .....	3-6
PBT Transmitter Components .....	3-6
PBT Transmitter Functions .....	3-7
NVT Transmitter .....	3-8
NVT Transmitter Components (Joystick Model) .....	3-8
NVT Transmitter Components (Paddle Lever Model) .....	3-9
NVT Transmitter Functions .....	3-10
GLT Transmitter .....	3-11
GLT Transmitter Components (Joystick Model) .....	3-11
GLT Transmitter Components (Paddle Lever Model) .....	3-12
GLT Transmitter Functions .....	3-13
GRT Transmitter .....	3-14
GRT Transmitter Components .....	3-14
GRT Transmitter Functions .....	3-16
Transmitter Setup .....	3-17
Placing the Push-button Labels .....	3-17

Transmitter Address Code and Frequency Channel . . . . .	3-18
Serial Nameplate . . . . .	3-18
Setting the Address Code and Frequency Channel of a Transmitter: . . . . .	3-19
Determining the Address Code . . . . .	3-19
Setting the Address Code . . . . .	3-20
Setting the Frequency Channel . . . . .	3-22
<b>Start-up and Operation . . . . .</b>	<b>3-23</b>
Holding the Transmitter . . . . .	3-23
JRT Transmitter . . . . .	3-23
PBT Transmitter . . . . .	3-24
NVT Transmitter . . . . .	3-25
GLT Transmitter . . . . .	3-26
GRT Transmitter . . . . .	3-27
Start-up . . . . .	3-28
Emergency Stop . . . . .	3-28
Using the Motion Push-buttons (JRT and PBT) . . . . .	3-28
Using the Joysticks and/or Paddle Levers (NVT, GLT and GRT) . . . . .	3-28
Optional Switches and Push-buttons . . . . .	3-29
Shutting Off the Transmitter . . . . .	3-29
<b>Transmitter Options . . . . .</b>	<b>3-30</b>
Spare Transmitter . . . . .	3-30
Address Plugs . . . . .	3-30
Crane Control Using Multiple Transmitters . . . . .	3-30
Pitch and Catch . . . . .	3-30
Independent/Combined Control of Multiple Cranes . . . . .	3-30
Safety Devices . . . . .	3-31
Press To Operate Safety Switch . . . . .	3-31
Lift To Operate Joysticks . . . . .	3-31
Lift To Operate Toggle Switches . . . . .	3-31
Tilt Switches . . . . .	3-31
Free Channel Search . . . . .	3-32
Setting the Odd/Even Channel Search of the Free Channel Search Function . . . . .	3-32
<b>Battery and Charger Information . . . . .</b>	<b>3-34</b>
Removing and Inserting the Battery From the Transmitter . . . . .	3-34
JRT Transmitter . . . . .	3-34

PBT Transmitter .....	3-35
NVT Transmitter.....	3-36
GLT Transmitter.....	3-37
GRT Transmitter.....	3-38
Charging the Battery.....	3-39
Standard Charger .....	3-40
Discharge Charger .....	3-40
Memory Effect .....	3-40

## **Chapter 4: Troubleshooting PulseStar•610**

Troubleshooting .....	4-3
Introduction.....	4-3
Common Problems .....	4-3
Questions to Ask.....	4-5
Transmitter .....	4-5
Receiver .....	4-5

## **Appendix A: Definitions and Abbreviations**

Definitions and Abbreviations .....	A-3
Definitions .....	A-3
Commonly Used Abbreviations .....	A-3

## **Appendix B: Specifications**

Specifications .....	B-3
System Specifications.....	B-3
JRT Specifications .....	B-3
PBT Specifications .....	B-4
NVT Specifications.....	B-5
GLT Specifications.....	B-6
GRT Specifications.....	B-7
Receiver Specifications.....	B-7

## **Appendix C: StarService and Warranty**

StarService Policy .....	C-3
On-Call Service.....	C-3
Warranty .....	C-3
Transmitter Loaner, Replacement & Repair Program .....	C-3
Receiver Repair Program .....	C-4
Limited Warranty And Terms Of Sale.....	C-5
Special Terms and Conditions: Orders of \$25,000 or More.....	C-6
Special Terms and Conditions: Orders for Special Control Panels.....	C-6

This page intentionally left blank.

## Welcome!

Welcome to the PulseStar•610 radio remote crane control system. Electromotive Systems has set a whole new standard in radio-remote performance, dependability, and value with this unique new line of modular transmitters and receivers. Without a doubt, PulseStar•610 is the ultimate solution for having precise, untethered, and safe control of overhead loads.

Using state-of-the-art synthesizer technology and the best circuit board manufacturing designs available, Electromotive Systems has eliminated many of the unreliable and expendable electromechanical components found in traditional radio remote systems.

The PulseStar•610 system consists of a receiver and a transmitter. The system uses PulseStar's synthesizer technology and operates over the 400-470 MHz band. PulseStar•610 is FCC approved with no site license required.

PulseStar's unique transmitter and receiver design provide a sophisticated, yet easy-to-understand, efficient, and safe radio remote control. PulseStar's modular design has the following advantages:

- Flexible design allows easy mixing and matching
- On-board diagnostic allow easy troubleshooting
- Standardized spare parts; kits available
- Simple design

## PulseStar•610 Components

The typical PulseStar•610 system consists of a receiver and transmitter kit. Each PulseStar•610 system is engineered per customer specification. Some PulseStar•610 systems can consist of multiple receivers and transmitters.

### Receiver

Each PulseStar•610 receiver has the following standard features:

- Start relay, horn relay, **Active E-STOP** relay, and **OPTION** relay.
- Up to 32 digital outputs.
- Up to 8 proportional channels (0 to 10V, 0 to 20 mA, etc.).
- Self-diagnostics to ensure trouble-free operation.
- 115 Volts or 230 Volts reconnectable input power supply for AC cranes.
- 12VDC or 24VDC reconnectable input power supply for DC cranes.
- Discrete 16 frequencies or autoscan.
- Sixteen-bit address code (over 65,000 combinations).
- Quick disconnect connector.

### Transmitter

The PulseStar•610 system can be supplied with several types of transmitters. The following are the most commonly used transmitters with the PulseStar•610 system:

- JRT hand held transmitter
- PBT hand held transmitter
- NVT belly box transmitter
- GLT belly box transmitter
- GRT belly box transmitter

Each PulseStar•610 transmitter has the following standard features:

- **Active E-STOP** for immediate stopping action.
- **Sleep Mode** to save battery charge and enhance safety.
- Removable key switch for added security.
- 16-bit address security code (over 65,000 possibilities).
- 330 foot range.
- Internal antenna.
- **START/HORN** push-button.
- Carrying belt or holster.

## How to Use This Manual

*PulseStar•610 Instruction Manual* has a comprehensive introduction chapter that you should read before installing, wiring, or operating the system. It introduces some of the many features of the PulseStar•610 system.

Chapter 2 covers installing and wiring the receiver, as well as start-up and test procedures to make sure the system is working properly before you begin regular operation.

Chapter 3 covers each type of transmitter individually. Refer to this chapter to identify the transmitter you have. This chapter also covers how to set the address code and frequency channel, start up, and how to operate the transmitter.

Chapter 4 gives you a basic troubleshooting guide, plus a checklist of things to look for before calling Electromotive Systems for service. In most cases, problems are minor and easy to solve.

## Important System Information

Before working with the PulseStar•610 system, read and understand the following important system information.

- Surge suppressors must be used when the PulseStar•610 receiver is controlling magnetic contactors.
- When not in use, the transmitter should be turned off and stored in a safe place to prevent unauthorized users from operating it.
- If the crane fails to respond properly, stop operation immediately, turn off the transmitter, and report the condition immediately to an appropriate technician or supervisor.
- Wire the receiver circuit board to the crane's ground.
- When using a standard external antenna mount it on a conductive metal surface with the same ground as the receiver circuit board. Remove any burrs from the antenna mounting hole and scrape away any paint which may prohibit the antenna base from making a good ground contact with the surface. Make sure that the antenna is not surrounded by metal or other conductive materials. Failure to properly install the antenna will result in intermittent operation.
- When using a gain flex external antenna make sure that your mounting location is at least 2 meters (6 feet) from any metallic or conductive objects. These objects may interfere with the antenna and cause intermittent operation.
- Before working on the transmitter, turn off the key switch and remove the battery.
- When taking a break or changing the battery, turn the transmitter off with the key switch.
- Always have a battery in the battery charger to ensure a fully charged battery.
- Perform initial setup or service work only if you have been authorized to do so. Use only Electromotive Systems spare parts.

This page intentionally left blank.

*c h a p t e r* **1**

---

**PulseStar•610**  
**System Overview**

This page intentionally left blank.

# PulseStar•610 System Overview

## Introduction

This chapter introduces the basic conceptual information that you should know before installing, wiring, and operating the PulseStar•610 system.

## Theory of Operation

The PulseStar•610 system consists of a transmitter kit and a receiver. The transmitter, using PulseStar's synthesizer technology, electronically generates a carrier frequency over which it and the receiver communicate. PulseStar•610 transmitters and receivers operate over the 400-470 Mhz frequency range (70 cm. band). To guarantee safety when the crane is being operated in conjunction with other radio controls, the receiver and transmitter are configured with the same address code. This way, the receiver only seeks out and accepts commands from the transmitter with the same address code.

**NOTE:** *PulseStar•610 receiver(s) and transmitter(s) already have their address code set up before they are shipped. Never change the address code in the receiver. The only time you should need to change the address code inside the transmitter is when you are setting up a spare or replacement transmitter. If you have any questions about address codes and how they are used, contact Electromotive Systems.*

## Active Emergency Stop (E-STOP) Function

One of the most important features of the PulseStar•610 is **Active E-STOP**. The transmitter continuously sends the **Active E-STOP** status signal, followed by the desired crane function. This constant communication between the transmitter and the receiver confirm that the ongoing operations are safe. If the **Active E-STOP** push-button is pressed on the transmitter, the **Active E-STOP** relay module in the receiver opens, and crane motion then ceases. The receiver is then in **Safe Mode**.

To restart the system after activating **Active E-STOP** via the **Active E-STOP** push-button, pull out the **Active E-STOP** push-button and press the **START/HORN** push-button.

**NOTE:** *There are other situations in which the system automatically goes into Active E-STOP without the operator pressing the Active E-STOP push-button on the transmitter. These are explained in later sections of the manual.*

**Active E-STOP** responds faster than any other PulseStar function. When **Active E-STOP** occurs, the system ignores any other signal it receives. **Active E-STOP** is the only signal that is recognized until the problem is corrected.

**Active E-STOP** is fail-safe and self-monitoring in both the transmitter and receiver. When you apply power to the receiver, it performs a self-test to make sure the **Active E-STOP** circuitry is working properly. If the receiver detects an error in the **Active E-STOP** circuitry, the system automatically goes into **Safe Mode**.

When you first turn on the transmitter, it also performs a self-test to make sure CPU circuitry is working properly. If it detects an error, the transmitter will not begin transmitting.

# Sleep and Time-Out Modes

## Transmitter Sleep Mode

To prevent accidental operation, PulseStar•610 transmitters have a built-in safety feature called **Sleep Mode**. If a transmitter is not used for 10 minutes, it turns itself off. While the transmitter is in **Sleep Mode**, the push-buttons, joysticks, or switches will not operate. To restart the transmitter cycle power (turn the key off and back on), and press the **START/HORN** push-button.

***NOTE:** If the transmitter has a selector switch or latching push-button, sleep mode will not occur because the selector switch or push-button is constantly sending a signal to the receiver.*

## Receiver Safe Mode

Another PulseStar•610 safety feature is the **Safe Mode**. The receiver will go into **Safe Mode** if any of the following should occur.

- The transmitter goes into **Sleep Mode**.
- Interference caused by other transmitters or other radio-controlled products in the area.
- The transmitter is taken out of its operating range (330 feet).
- The **Active E-STOP** push-button is activated.
- There is a failure with the **Active E-STOP** circuitry.

When the receiver loses the transmitter carrier frequency signal, the **Time Out Waiting Period** process begins. The **Time Out Waiting Period** is factory set at 450msec, however it can be extended to 2 seconds. If the receiver does not regain the transmitter carrier frequency signal before the **Time Out Waiting Period** expires, the receiver immediately goes into **Safe Mode**. When in **Safe Mode** the receiver shuts off power to the output modules, and drops out the mainline contactor by opening the **Active E-STOP** relay module.

To restart the system, make sure the transmitter carrier frequency signal is being picked up by the receiver. Then press the **START/HORN** push-button on the transmitter.

*c h a p t e r* **2**

---

**The PulseStar•610 Receiver**

This page intentionally left blank.

# Overview

This chapter tells you how to install and wire the PulseStar•610 receiver. It also contains start-up and test procedures so you can ensure that the transmitter(s) and receiver are working properly before you actually use them to control the overhead crane.

This chapter covers the following information.

- Receiver Components
- Installing the PulseStar•610 Receiver
- Wiring the PulseStar•610 Receiver
- Startup and Test Procedures
- Receiver Options



## **WARNING**

Only authorized personnel are permitted to perform the initial installation, setup or service work.  
Use only Electromotive Systems spare parts.

# Receiver Components

The PulseStar•610 receiver receives commands from the remote transmitter, and interfaces with the crane controls to move the crane. The PulseStar•610 receiver is custom built for each application, however each receiver has common components. See Figure 2.1: PulseStar•610 Receiver Layout for a typical PulseStar•610 receiver layout.

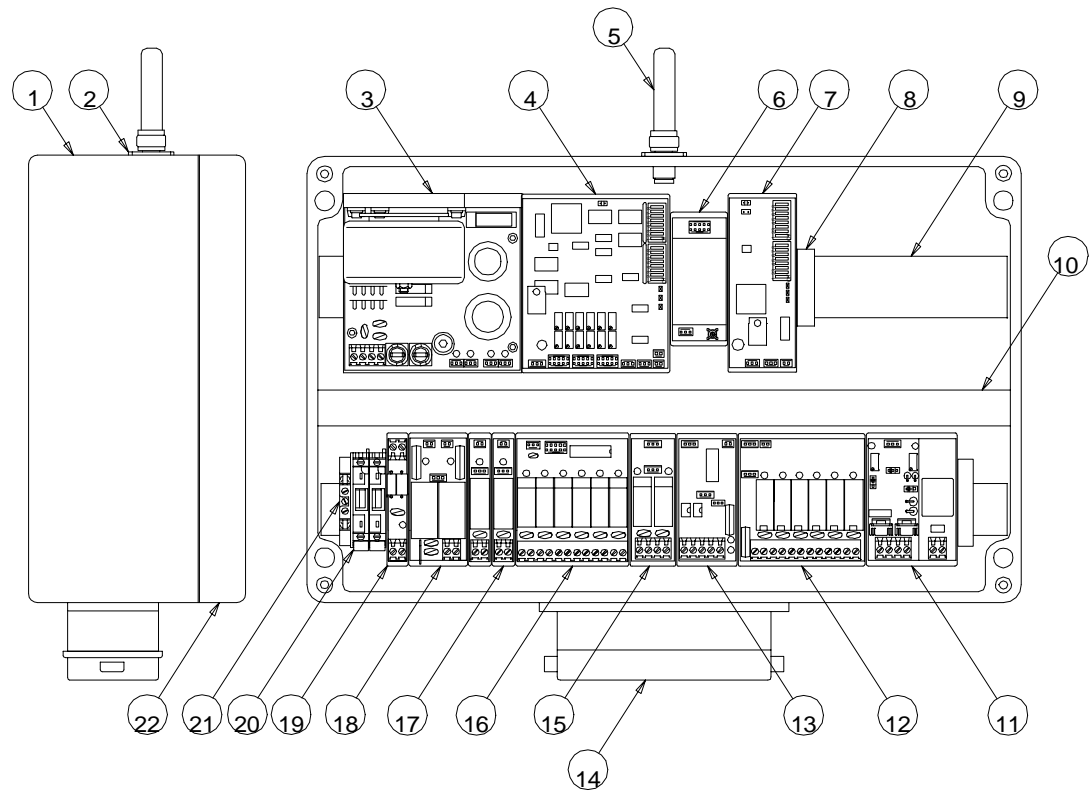

**Figure 2.1: PulseStar•610 Receiver Layout**

- |                                 |   |
|---------------------------------|---|
| 1. Enclosure                    | 12. AD5S Module (analog to 5 step)                |
| 2. Antenna Base                 | 13. SYM-2 Module (0-10vdc, 0-20mA)                |
| 3. Power Pack (50/110/240vac)   | 14. Quick Disconnect Base                         |
| 4. Decoder Module               | 15. RK-1 Module (directional contacts)            |
| 5. Miniflex Antenna             | 16. REL-6 Module                                  |
| 6. Standard RF Module           | 17. Normally Open or Normally Closed Relay Module |
| 7. Active E-STOP Decoder Module | 18. SNZ Active E-STOP Module                      |
| 8. End Stop                     | 19. EMVS-1 Interference Suppressor Module         |
| 9. DIN Rail                     | 20. Line Terminal Block w/Fuse                    |
| 10. Wire Duct                   | 21. Ground Terminal Block (PE)                    |
| 11. ACM-1 Module (0-20vac)      | 22. Enclosure Cover                               |

# Installing the PulseStar•610 Receiver



## WARNING

- Only authorized personnel are permitted to perform the initial setup or service work. Use only Electromotive Systems parts.
- Do NOT touch any circuit components on the circuit board while the main AC or DC power is on.
- Do NOT change the address code settings in the receiver.
- Do NOT run control wires with power wires.
- Surge Suppressors must be used with all magnetic contactors that are controlled by the PulseStar•610 system.

## Assessing the Receiver Enclosure Environment

When you choose a location for the receiver enclosure, consider the following guidelines.

1. The Receiver can be operated on the following power supplies:
  - 12-24V, DC (+/-50%)
  - 50V/110V/240V (+/-20%), AC, Single Phase
2. Ensure that the receiver enclosure will be protected or isolated from:
  - Ambient temperatures outside the range of -18°F to 158°F (-25°C to +70°C) (Consult Electromotive Systems if you must exceed this temperature range).
  - Corrosive gases or liquids.
3. As much as possible, ensure that the receiver is not surrounded by metal or other conductive materials that could prevent the internal antenna from receiving the transmitter signal. If you are using an external antenna, ensure that it is not surrounded by metal or other conductive materials.

## Serial Nameplate

Before you prepare to mount the receiver, locate the serial nameplate. The receiver serial nameplate is typically located on the right hand side of the enclosure. The serial nameplate contains the Electromotive Systems job number, the address code used by the system, and the frequency channel used by the system. **The Electromotive Systems job number is important if you ever need to call Electromotive Systems for service.** When you mount the receiver, ensure that the serial nameplate is visible so that you can easily read the Electromotive Systems job number.

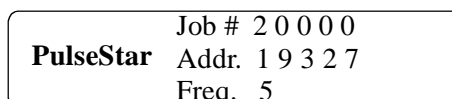

*Figure 2.2: Serial Nameplate*

## Mounting the PulseStar•610 Receiver

Refer to Figure 2.3: Receiver Dimensions for mounting the PulseStar•610 receiver.

1. Determine the position of the receiver.
2. Determine the sizes and connection locations for the components that need to be wired.
3. Loosen the screws holding the cover of the enclosure.
4. Using the diameter and dimensions shown in Figure 2.3: Receiver Dimensions, drill holes into the mounting surface. The depth of the hole depends on the type of screw you are using to mount the receiver enclosure.

**NOTE:** *The PulseStar•610 receiver is custom built for each application. The vast majority of applications use the receiver specified below. However some applications require a larger enclosure (DC cranes, multi-systems). Please consult Electromotive Systems prior to installation if you have questions.*

5. Insert the screws through each of the mounting holes, and then tighten the mounting screws to the mounting surface.
6. Lay out the wire runs. At a minimum, use #16 AWG for power wiring.
7. If receiver is to be mounted inside a control panel or enclosure, an external antenna is necessary.

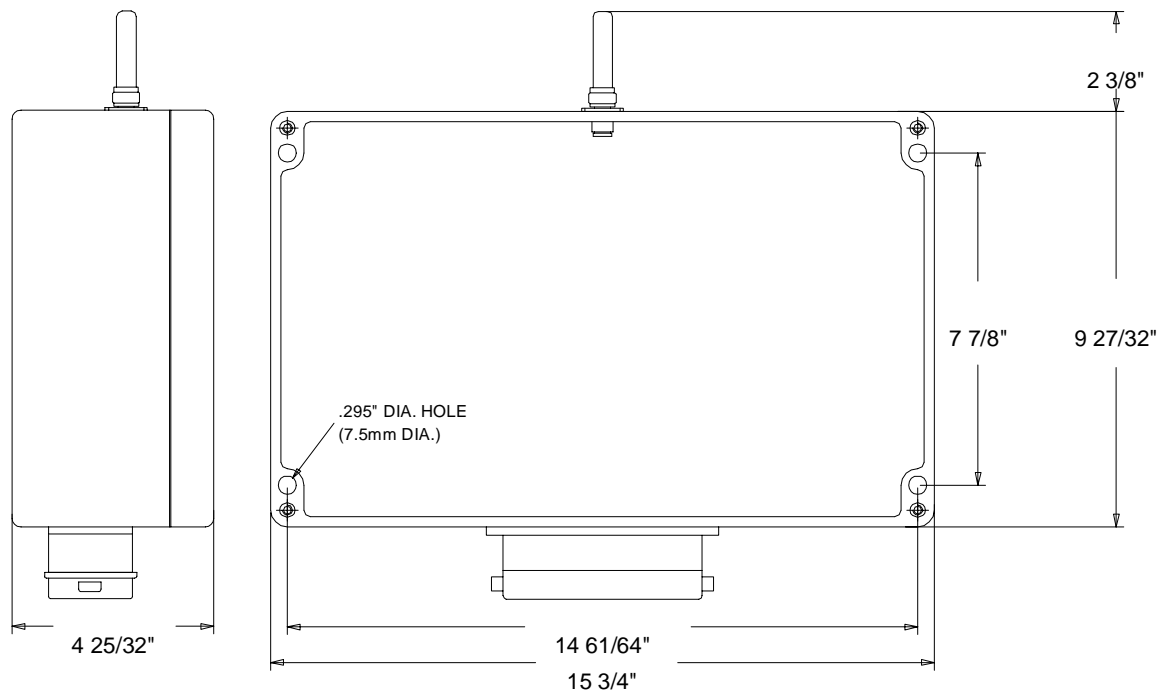

**Figure 2.3: Receiver Dimensions**

## Connecting a Standard External Antenna

In some cases, such as when the receiver is inside a panel enclosure, you may need to connect an external antenna to the PulseStar•610 receiver instead of using the miniflex antenna. Mount the standard external antenna on a metal surface with the same ground as the receiver circuit board. Make sure that the antenna is not surrounded by metal or other conductive materials. For best reception, the antenna should be pointing upward.

**NOTE:** *Failure to properly install the antenna will result in intermittent operation.*

1. Drill a  $\frac{9}{16}$  inch hole through the enclosure.
2. Insert the connector base through the hole so that the antenna side is on the outside, and the base is seated firmly against the enclosure surface. Remove any burrs from the antenna mounting hole and scrape away any paint which may prohibit the antenna base from making ground contact with the enclosure.
3. Assemble the antenna according to Figure 2.4: Standard External Antenna.

1. Antenna Pole
2. Enclosure
3. Antenna Base
4. Antenna Cable

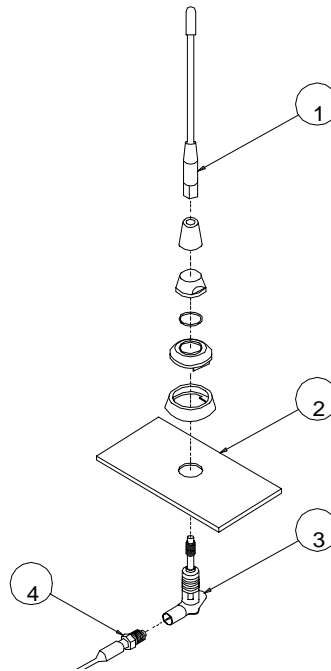

**Figure 2.4: Standard External Antenna**

4. Screw the antenna pole onto the antenna base.
5. Remove the miniflex antenna mounted on the PulseStar•610 receiver by unscrewing it from the antenna base.
6. Connect the antenna cable connector to the antenna base on the PulseStar•610 receiver housing.
7. Bundle any excess antenna cable by looping the cable, then flatten the cable loop and tighten both ends of the flattened cable with tie wraps or equivalent.

**NOTE:** *Never run the antenna cable with power or control wiring. Doing so will result in intermittent operation.*

## Connecting a Gain Flex Antenna

Some applications require the use of a gain flex antenna. The gain flex antenna can extend the operating range of the PulseStar•610 system up to 300 meters (1000 feet). It is also used with intrinsically safe applications, and applications where a standard antenna is too difficult to mount. Make sure that there are no metallic or other conductive materials within 2 meters (6 feet) radius of the gain flex antenna. These objects will interfere with the reception of the gain flex antenna, and will result in intermittent crane operation. For best reception, the antenna should be pointing upward.

**NOTE:** *Failure to properly install the antenna will result in intermittent operation.*

Refer to Figure 2.5: Gain Flex Antenna when installing the gain flex antenna.

1. Affix the antenna base of the gain flex antenna to a mounting surface by using the two tie wraps included with the antenna kit. For best reception the antenna base should be mounted vertically with the antenna base pointing upward.

1. Antenna Pole
2. Antenna Base
3. Tie Wrap
4. Antenna Cable

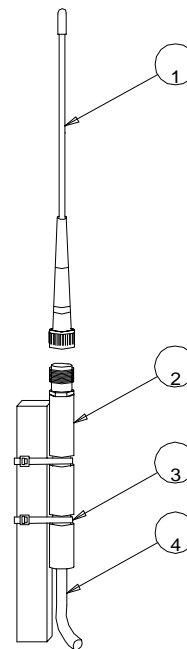

**Figure 2.5: Gain Flex Antenna**

2. Screw the gain flex antenna pole onto the antenna base.
3. Remove the miniflex antenna mounted on the PulseStar•610 receiver by unscrewing it from the antenna base.
4. Connect the antenna cable connector to the antenna base on the PulseStar•610 receiver housing.
5. Bundle any excess antenna cable by looping the cable, then flatten the cable loop and tighten both ends of the flattened cable with tie wraps or equivalent.

**NOTE:** *Never run the antenna cable with power or control wiring. Doing so will result in intermittent operation.*

# Wiring the PulseStar•610 Receiver

Each Pulsestar•610 system is supplied with a wiring diagram which shows how to connect the Pulsestar•610 system to your crane controls. Please use this wiring diagram when interfacing the Pulsestar•610 system to your crane controls. If the Pulsestar•610 system is part of a TControls control panel, the receiver will already be wired to the crane controls.



## WARNING

- Only authorized personnel are permitted to perform the initial setup or service work. Use only Electromotive Systems parts.
- Do NOT touch any circuit components on the circuit board while the main AC or DC power is on.
- Do NOT change the address code settings in the receiver.
- Do NOT run control wires with power wires.
- Surge Suppressors must be used with all magnetic contactors that are controlled by the PulseStar•610 system.

## Quick Disconnect Plug

All Pulsestar•610 receivers are supplied with quick disconnect plugs. The plugs will contain either 24 or 64 pins depending on the number of outputs needed. The receiver outputs are connected to the quick disconnect base. It is the customers responsibility to wire the female quick disconnect plug and terminate this plug to the crane controls. The 24 pin plug is a screw terminal type, while the 64 pin plug requires crimp pin terminations. These pins are provided with the quick disconnect plug hardware.

## Terminating Wires to the Quick Disconnect Plug

1. Using the wire runs created in the Mounting the PulseStar•610 Receiver section in this chapter, connect the single-phase power wires and output wires to the female quick disconnect plug using the wiring diagram provided with the system.

*NOTE: Ensure that the receiver signal wires and the high voltage power wires cross at 90° angles. Never combine high voltage power and control wires in the same cable run.*

2. Install Resistor/Capacitor (RC) type surge absorbers (not MOV type) across the coils of any contactors installed in the crane control circuit.

*NOTE: Surge suppression is required on all magnetic contactors controlled by the receiver. Uncommanded crane motion and/or serious component damage may occur if surge suppressors are not used.*

## Quick Disconnect Plug Housing Orientation

The orientation of the female connector housing can be changed to suit the customer's needs. Both the male and female connector modules are labeled. Labeling is numeric for the 24 pin connector, and alpha-numeric for the 64 pin connector.

To change the connector housing orientation:

1. Loosen the retaining screws.
2. Separate the connector module from the connector housing.
3. Rotate the housing to the appropriate orientation.
4. Re-insert the connector module.
5. Tighten retaining screws.

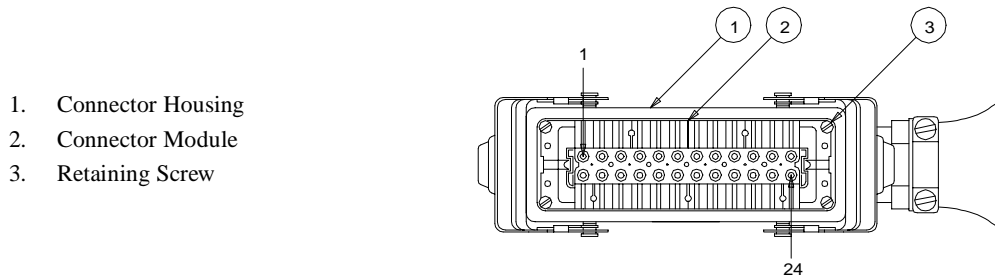

*Figure 2.6: 24 Pin Quick Disconnect Layout*

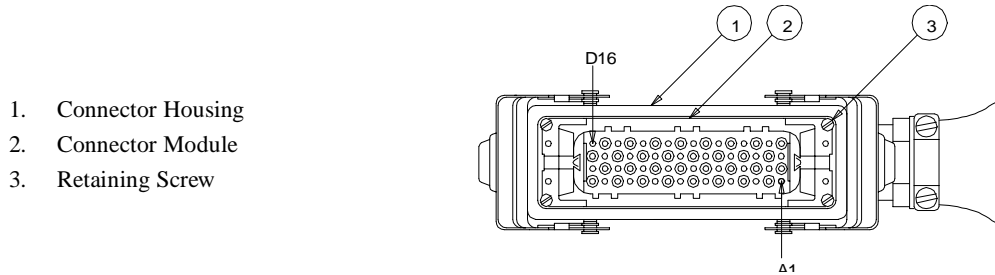

*Figure 2.7: 64 Pin Quick Disconnect Layout*

# Startup and Test Procedures



## WARNING

- Only authorized personnel are permitted to perform testing or service work.
- Make sure the crane is clear of any obstructions, and there is no load on the hook.
- Serious injury or component damage can occur if the PulseStar•610 system is not properly installed and tested.

## Pre-operation check list

Before you begin operating the PulseStar•610 system to control your overhead crane, confirm the following check list to ensure that your system is working safely and correctly.

- There is a fully-charged battery in the transmitter.
- The second battery is in the charger being charged at all times. Ensure that the battery charger is plugged into a power source that is not turned off at night with the crane.
- The **Active E-STOP** push-button on the transmitter is pushed in.
- The joysticks and/or paddle levers are in the center (off) position (NVT, GLT, GRT transmitters), or the motion push-buttons are not depressed (JRT, PBT transmitters).

## Testing the Receiver

As you perform the following startup test, place yourself in front of the PulseStar•610 receiver with the cover off so that you can clearly see each LED and connection. Refer to Figure 2.8: PulseStar•610 Receiver Test Layout for LED and module locations.

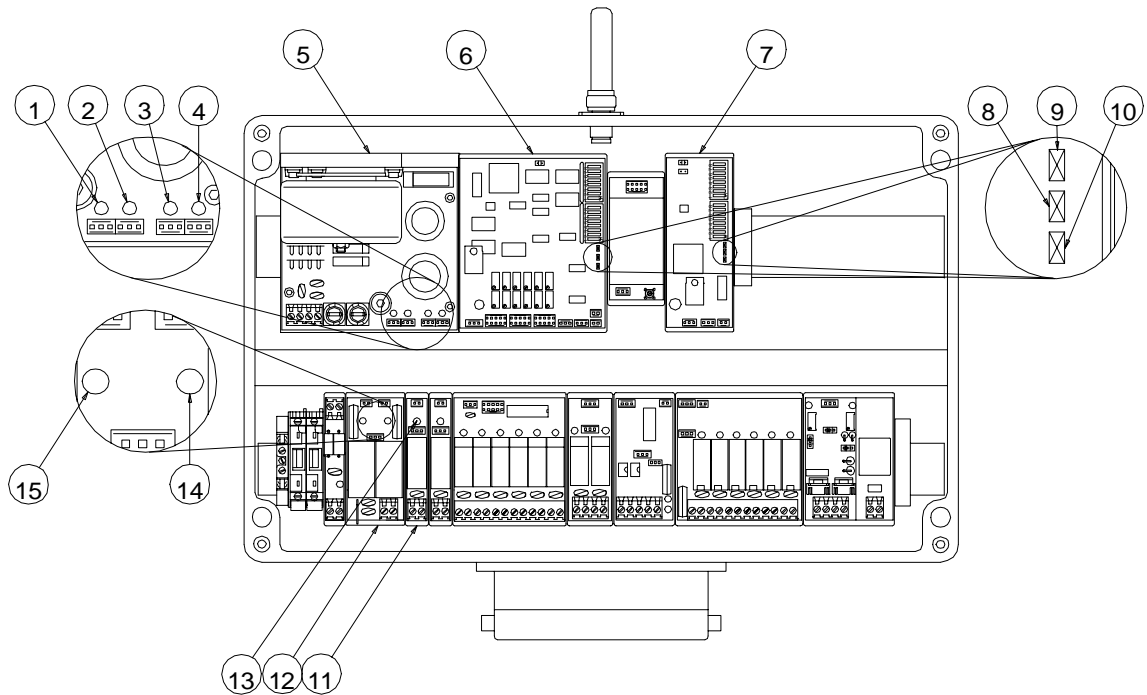

**Figure 2.8: PulseStar•610 Receiver Test Layout**

- |                                 |                                      |
|---------------------------------|--------------------------------------|
| 1. Power Pack X1 LED            | 9. CPU Standby LED                   |
| 2. Power Pack X2 LED            | 10. Active E-STOP LED                |
| 3. Power Pack X3 LED            | 11. Start Relay                      |
| 4. Power Pack X4 LED            | 12. SNZ Active E-STOP Module         |
| 5. Power Pack (50/110/240vac)   | 13. Start Relay LED                  |
| 6. Decoder Module               | 14. Active E-STOP Decoder E-STOP LED |
| 7. Active E-STOP Decoder Module | 15. Decoder E-STOP LED               |
| 8. Telegram LED                 |                                      |

1. Turn on the power to the receiver. The CPU Standby LED should flash yellow to indicate that the microprocessor is functioning properly and X1 LED, X2 LED, and X3 LED on the Power Pack should turn on.
2. Insert the key into the key switch and turn to the ON position. A buzzer sounds to indicate the start of a diagnostic test. The diagnostic test checks for the following.
  - The CPU and software is functioning properly.
  - The joysticks and/or paddle levers are in the center (off) position (NVT, GLT, GRT transmitter) or the motion push-buttons are not pressed down (JRT, PBT transmitter).

**NOTE:** *With the NVT, GLT and GRT transmitter the buzzer will sound a second time if the transmitter passes the diagnostic tests.*

3. After the diagnostic test the following should occur.
  - The Telegram LED should flash on the Decoder Module and **Active E-STOP** Decoder Module to indicate that the receiver is detecting a valid signal from the transmitter.
4. Pull out the **Active E-STOP** push-button. The following should occur.
  - The X4 LED on the Power Pack should turn on.
  - The Decoder E-STOP LED and **Active E-STOP** Decoder LED on the **Active E-STOP** relay module should turn on.
5. Test the **Active E-STOP** function by pushing in the **Active E-STOP** push-button on the transmitter. The following should occur.
  - The X4 LED on the Power Pack turns off.
  - The Decoder E-STOP LED and **Active E-STOP** Decoder LED on the **Active E-STOP** relay module turn off.
6. Pull the **Active E-STOP** push-button out and press the **START/HORN** push-button on the transmitter. The start relay LED should turn on, and the start relay should close to activate the mainline contactor, and the horn will sound (when supplied).
7. Activate the motion push-buttons (JRT or PBT), joysticks and/or paddle levers (NVT, GLT, or GRT) to test the crane functions. Confirm that the crane moves appropriately and that the LEDs corresponding to the motion relays or analog output modules turn on. These LED's will be located on the individual motion modules for analog signals, or directly above the discrete relays for digital signals.
8. Activate the **OPTION** function(s) (if applicable) to test optional crane functions. Confirm that the crane moves appropriately and that the LEDs corresponding to the relays or modules turn on.
9. Turn the key switch to OFF. The following should occur.
  - The X4 LED on the power pack turns off.
  - The Decoder E-STOP LED and **Active E-STOP** Decoder LED on the **Active E-STOP** relay module turn off.
  - The Telegram LED on the Decoder Module and **Active E-STOP** Decoder Module turn off.
10. If all transmitter and receiver functions work properly, the system is ready for use.

*NOTE: If you experienced any problems during this test refer to Chapter 4 Troubleshooting PulseStar•610 for help, or call Electromotive Systems.*

## Changing the Frequency Channel of the Receiver

### Standard RF Module

The standard RF module is capable of receiving one of 16 discrete frequency channels. The frequency channel of the transmitter and receiver are set by Electromotive Systems prior to shipment. Should interferences occur on a particular frequency channel it may be necessary to change the frequency channel of the receiver and transmitter.

**NOTE:** *Do not change the receiver address code under any circumstances. Contact Electromotive Systems before making any frequency channel changes.*



#### WARNING

- Do NOT change the address code or frequency channel of the original transmitter that came with your PulseStar•610 system without first contacting Electromotive Systems.
- Do NOT change the address code settings in the PulseStar•610 receiver.
- Do NOT operate two transmitters set with the same frequency channel and address codes as the receiver at the same time.

The PulseStar•610 transmitter and receiver operate over the 400—470 MHz frequency range (70-cm band). There are 16 possible frequencies and 16 corresponding channels available. Figure 2.9: Receiver Frequency Channel Diagram shows each channel, its respective frequency, and the position of the five jumpers according to the diagram for the frequency channel you are setting.

1. Remove the receiver cover.
2. Reference Figure 2.9: Receiver Frequency Channel Diagram to locate the Frequency Channel Jumper Block inside the receiver.
3. Set the frequency channel jumpers according Figure 2.9: Receiver Frequency Channel Diagram for the appropriate frequency channel. A black box indicates that a jumper should be present in that position. A white box indicates there should be no jumper present in that position.
4. When finished, replace the receiver cover and tighten the four screws.

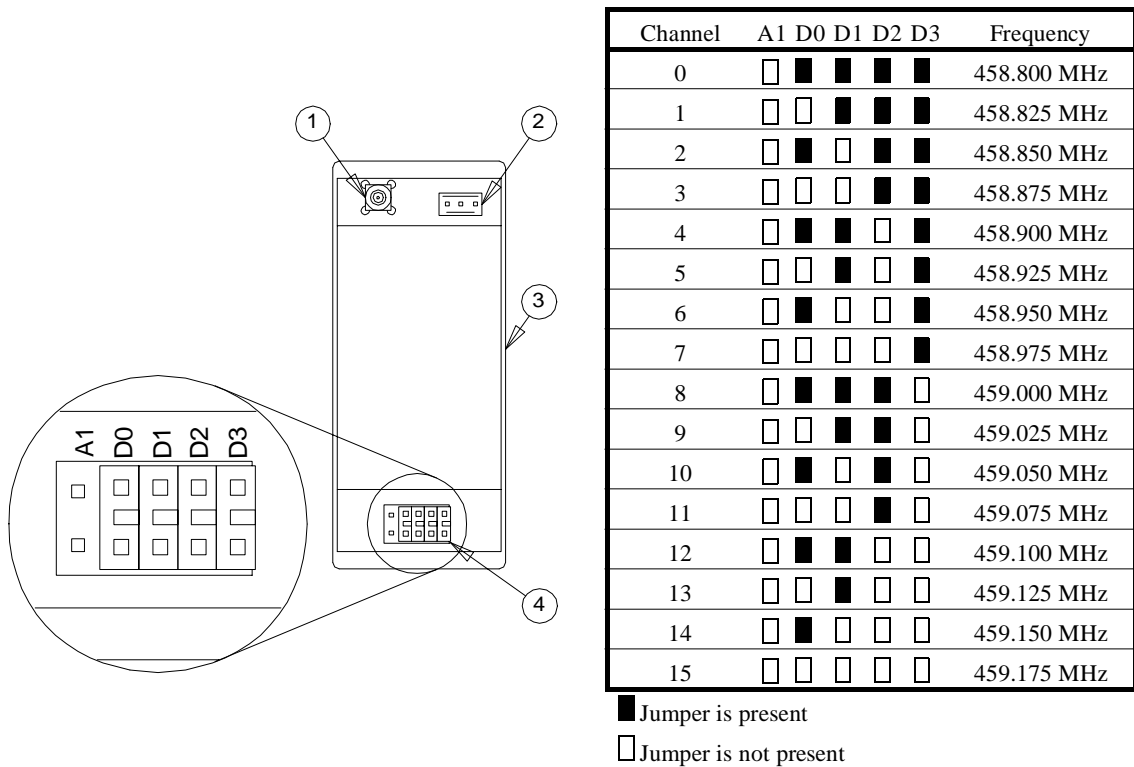

**Figure 2.9: Receiver Frequency Channel Diagram**

- |                      |                                   |
|----------------------|-----------------------------------|
| 1. Antenna Connector | 3. Standard RF Module             |
| 2. TTL Connector     | 4. Frequency Channel Jumper Block |

## Scan RF Module

The scan RF module is a module used in conjunction with **Free Channel Search**, or when more than one transmitter will be used to control the crane. The scan RF module is used when **AutoScan** is required in the receiver.

**AutoScan** is where the receiver ‘scans’ for valid frequency channels. Once a valid frequency channel is found, the receiver checks for a valid address code. If the frequency channel does not contain the correct address code, the receiver continues to scan until a valid frequency channel containing the correct address code is found. Once a valid frequency channel containing the correct address code is found, the receiver locks on to that frequency channel and ignores all other signals.

The scan RF module is capable of scanning for up to 16 frequency channels, however the factory setting is for scanning either the odd or even frequency channels. The scan RF module is used with PulseStar•610 systems which have **Free Channel Search** in the transmitter, or are set up for pitch and catch which does not use interlocking.

The frequency channel of the transmitter and scan mode setting of the receiver are set by Electromotive Systems prior to shipment. Should interferences occur on a particular frequency channel it may be necessary to change the frequency channel of the transmitter, and the scan mode setting of the scan RF module in the receiver. Contact Electromotive Systems before making any frequency channel changes.

**NOTE:** *Do not change the receiver address code under any circumstances.*



### WARNING

- Do NOT change the address code or frequency channel of the original transmitter that came with your PulseStar•610 system without first contacting Electromotive Systems.
- Do NOT change the address code settings in the PulseStar•610 receiver.
- Do NOT operate two transmitters set with the same frequency channels and address codes as the receiver at the same time.

The PulseStar•610 transmitter and receiver operate over the 400—470 MHz frequency range (70-cm band). There are 16 possible frequencies and 16 corresponding channels available. Figure 2.10: Scan RF Module shows the scan RF module and location of the configuration jumpers.

## Setting the Scan Mode

1. Remove the receiver cover.
2. Set the jumpers to scan for the frequency channel used by the transmitter(s).
  - Solder jumper J1 selects either 8 channel or 16 channel scan. When solder jumper J1 is open, it scans for 8 channels. When closed it scans 16 channels. Factory setting is for 8 channel scan.
  - Jumper J2 is the odd/even channel scan select. When jumper J2 is closed, it scans for odd channels (1, 3, 5, 7, 9, 11, 13, 15). When open it scans for even channels (0, 2, 4, 6, 8, 10, 12, 14).

*NOTE: When solder jumper J1 is set for 16 channel scan, jumper J2 is ignored.*

3. When finished, replace the receiver cover and tighten the four screws.

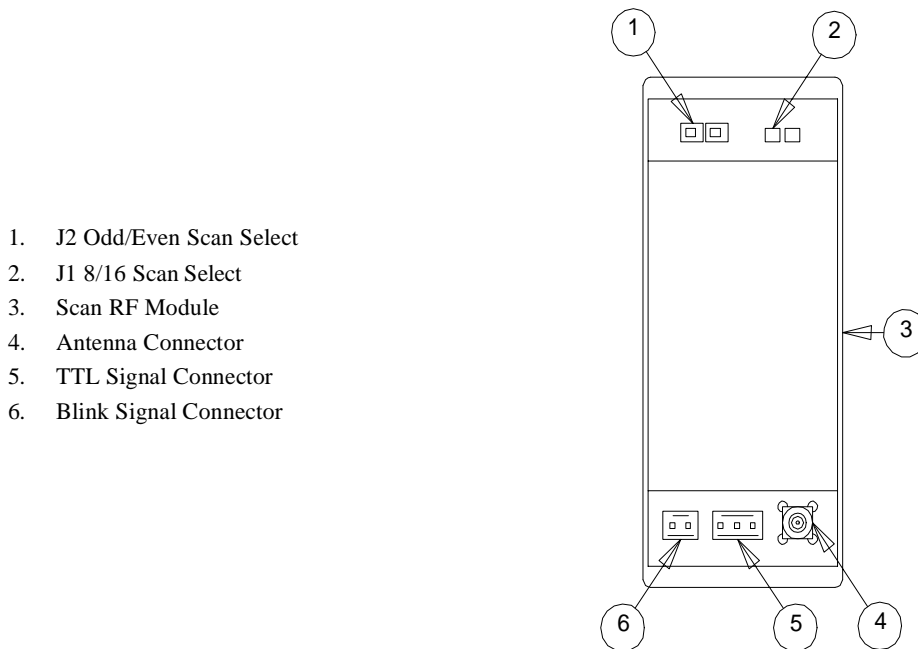

**Figure 2.10: Scan RF Module**

# Receiver Options

All PulseStar•610 receivers are engineered specifically to operate your crane. Because of this you may have features and functionality which is not covered in the PulseStar•610 manual. The following are some of the more common options which pertain to the PulseStar•610 receiver. If you have any questions about the functionality of your PulseStar•610 system contact Electromotive Systems.

## Range Limitation

The PulseStar•610 receiver can limit the operating range of the PulseStar•610 system. Due to the nature of radio frequency transmissions it is not possible to limit the operating range to an exact distance. However it is possible to limit the operating range to a percentage of maximum range.

A special module is used inside the PulseStar•610 receiver which measures the PulseStar•610 transmitter signal strength. A threshold point is determined by using a potentiometer on the range limitation module. If the power of the transmitted signal is lower than the threshold point, the receiver goes into **Safe Mode**, and the **Active E-STOP** circuitry is activated. The range limitation module has an operating range of 80' to 200' +/- 20% (20M to 50M +/- 20%).

## Special Enclosures

### Intrinsically Safe Systems

The PulseStar•610 receiver can be provided as intrinsically safe. A standard receiver can be mounted inside an explosion-proof enclosure, or the receiver can be provided with it's own explosion-proof enclosure for mounting by the customer. The PulseStar•610 receiver can accommodate all Class I and Class II environments when provided in this manner.

### Marine Duty/Corrosion Resistant Systems

The PulseStar•610 receiver can be provided with a NEMA 4X enclosure, as well as enclosures which are resistant to corrosive environments such as marine duty and galvanizing/pickling.

*c h a p t e r* **3**

---

**The PulseStar•610  
Transmitter**

This page intentionally left blank.

# Overview

This chapter tells you how to configure and use the PulseStar•610 transmitter. Several types of transmitters are available for use with the PulseStar•610 system. This manual will cover the basic features of each transmitter, as well as some of the more common options. For a complete description of how your engineered PulseStar•610 system functions contact Electromotive Systems.

Once you've installed, wired, and tested the PulseStar•610 system, you are ready to use it. This chapter covers the following information.

- PulseStar•610 Transmitters
- Start-up and Operation
- Transmitter Options
- Battery and Charger Information

# PulseStar•610 Transmitters

There are several types of transmitters which can be used with a PulseStar•610 system. They include:

- JRT hand held transmitter
- PBT hand held transmitter
- NVT belly box transmitter
- GLT belly box transmitter
- GRT belly box transmitter

## JRT Transmitter

The JRT transmitter is a hand-held radio control device with push-buttons used to control crane motions. The JRT transmitter can control up to three crane motions with two speed control, and one crane motion with single speed control. The crane motion push-buttons which control two speeds have two detents. The **START/HORN** and **OPTION** push-buttons are single detent.

### JRT Transmitter Components

The JRT transmitter has the following components. Refer to Figure 3.1: JRT Transmitter Layout to identify parts of the JRT transmitter.

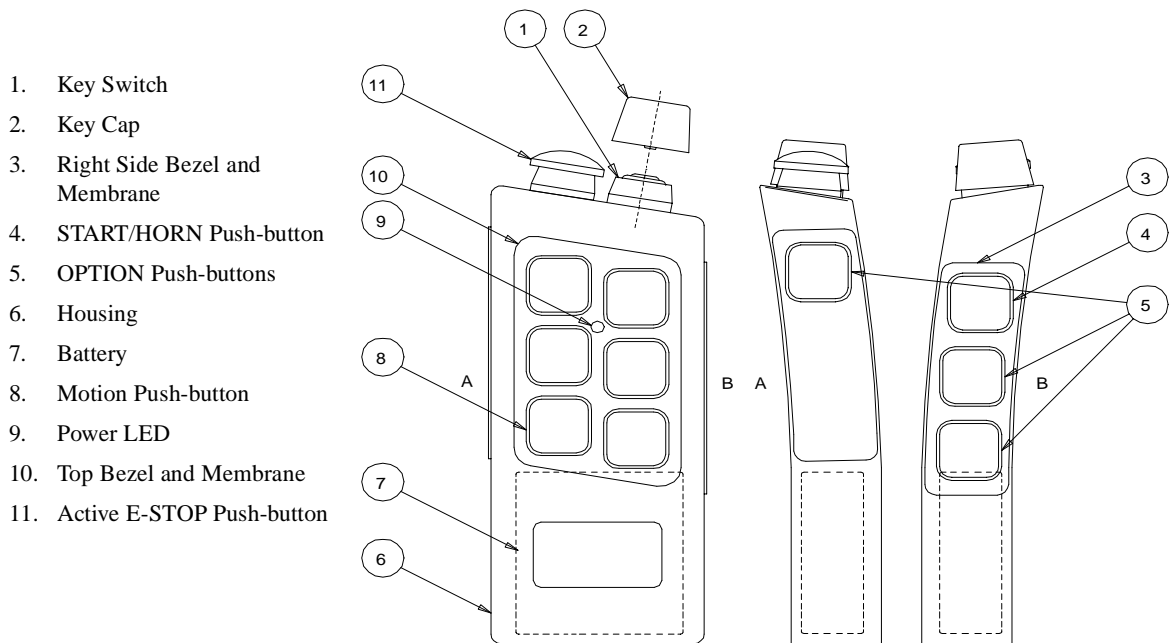

*Figure 3.1: JRT Transmitter Layout*

## JRT Transmitter Functions

The following describes the basic functionality of the JRT transmitter. Please reference Figure 3.1: JRT Transmitter Layout for the location of these functions.

**START/HORN Push-button.** The **START/HORN** push-button activates the mainline contactor and sounds the horn (when provided). Once the mainline contactor has been turned on, pressing this push-button sounds the horn only (when provided).

**Active E-STOP Push-button.** Pressing the **Active E-STOP** push-button will place the receiver in **Safe Mode**. The **Active E-STOP** push-button must be pulled out for the transmitter to control the crane motions.

**NOTE:** *The Active E-STOP push-button is for emergency situations only. Do NOT use it as an OFF switch. Use the key switch to turn the transmitter on and off.*

**Power LED.** As soon as the JRT transmitter is turned on, this LED will emit a flashing red light. The transmitter performs a self-test to check the JRT software. If it passes, the LED changes to flashing green and continues flashing green until the transmitter is turned off. This LED changes to flashing red when the battery is low.

**Key Switch.** The key switch turns the transmitter on and off. It only works with the key cap inserted, and the key cap can only be removed while in the OFF position.

**Motion Push-buttons.** These push-buttons control the various crane motions and are labeled accordingly.

**OPTION Push-buttons.** These push-buttons can control a single speed crane motion such as a hoist block rotate, or various crane auxiliary functions.

## PBT Transmitter

The PBT-4 and PBT-5A transmitter is a hand-held radio control device with push-buttons used to control crane motions. Both transmitters can control up to four crane motions with two speed control. The PBT-5A provides independent/combined control of two bridge cranes or two trolley/hoists on a single bridge crane.

The crane motion push-buttons have two detents corresponding to two speeds. The **START/HORN**, **OPTION**, and **SELECTOR** (PBT-5A only) push-buttons are single detent.

### PBT Transmitter Components

The PBT-4 and PBT-5A transmitters have the following components. Refer to Figure 3.2: PBT-5A Transmitter Layout to identify parts of the PBT transmitter.

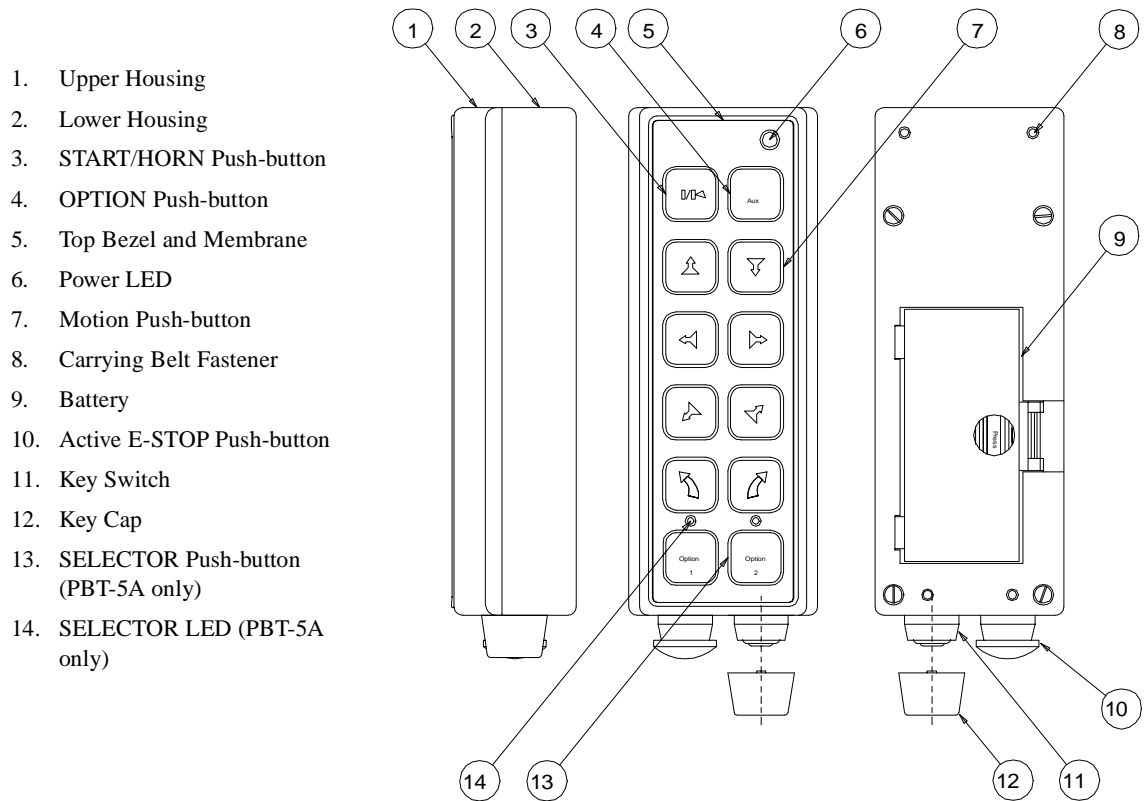

*Figure 3.2: PBT-5A Transmitter Layout*

## PBT Transmitter Functions

The following describes the basic functionality of the PBT transmitter. Please reference Figure 3.2: PBT-5A Transmitter Layout for the location of these functions.

**START/HORN Push-button.** The **START/HORN** push-button activates the mainline contactor and sounds the horn (when provided). Once the mainline contactor has been turned on, pressing this push-button sounds the horn only (when provided).

**Active E-STOP Push-button.** Pressing the **Active E-STOP** push-button will turn off the mainline contactor. The **Active E-STOP** push-button must be pulled out for the transmitter to control the crane motions.

**NOTE:** *The Active E-STOP push-button is for emergency situations only. Do NOT use it as an Off switch. Use the key switch to turn the transmitter on and off.*

**Power LED.** As soon as the PBT is turned on, this light will flash green. This indicates that the transmitter powered up and has passed a diagnostic check. If the **OPTION** push-button in the transmitter is set to **latching**, the power LED will flash red whenever the **OPTION** push-button is activated.

**Key Switch.** The key switch turns the transmitter on and off. It only works with the key cap inserted, and the key cap can only be removed while in the OFF position.

**Crane Motion Push-buttons.** These push-buttons control the various crane motions and are labeled accordingly.

**OPTION Push-button.** This push-button controls the **OPTION** function such as **Micro-Positioning Control™**. A jumper on the PBT circuit board controls whether the **OPTION** push-button is **latching** or **momentary**.

- If the **OPTION** push-button is set to **momentary**, the **OPTION** function is activated only while the operator holds down the push-button. As soon as the push-button is released, the function stops.
- If the **OPTION** push-button is set to **latching**, the **OPTION** function is activated when the push-button is depressed, and the power LED is flashing red. When the push-button is pressed a second time and released, the function stops and the power LED flashes green.

**SELECTOR Push-buttons (PBT5A ONLY).** These push-buttons control the independent or combined control of main and aux hoists, two trolley/hoists, or two cranes. These push-buttons are electronically latched. The **SELECTOR** function is active when the push-button is depressed, and the **SELECTOR** LED is on. When the push-button is pressed a second time and released, the function stops, and the **SELECTOR** LED turns off.

**SELECTOR LED's (PBT5A ONLY).** These LED's indicate which **SELECTOR** push-button is activated.

## NVT Transmitter

The NVT transmitter has a “belly box” design where the operator maneuvers joysticks or paddle levers to control crane motions. The standard NVT joysticks and paddle levers offer proportional speed control without detents. Joysticks are available which provide up to three speeds with detents. The NVT joystick model can contain up to two dual axis joysticks for up to four motion control. The NVT paddle lever model can contain up to six single axis paddle levers for up to six motion control.

The NVT also offers a **SELECTOR** toggle switch for controlling multiple crane motions with one joystick or paddle lever. With the **SELECTOR** toggle switch, the NVT can control up to seven crane motions for independent/combined control.

### NVT Transmitter Components (Joystick Model)

The NVT joystick transmitter has the following components. Refer to Figure 3.3: NVT Joystick Transmitter Layout to identify parts of the NVT transmitter.

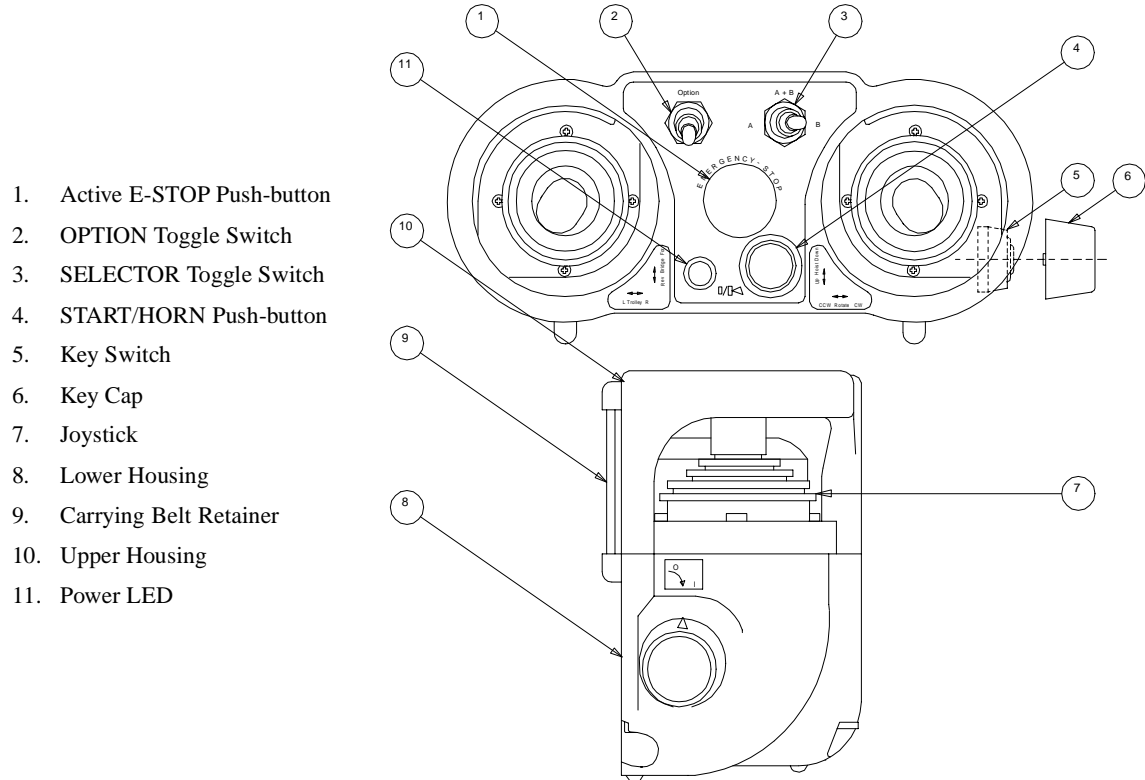

*Figure 3.3: NVT Joystick Transmitter Layout*

## NVT Transmitter Components (Paddle Lever Model)

The NVT paddle lever transmitter has the following components. Refer to Figure 3.4: NVT Paddle Lever Transmitter Layout to identify parts of the NVT transmitter.

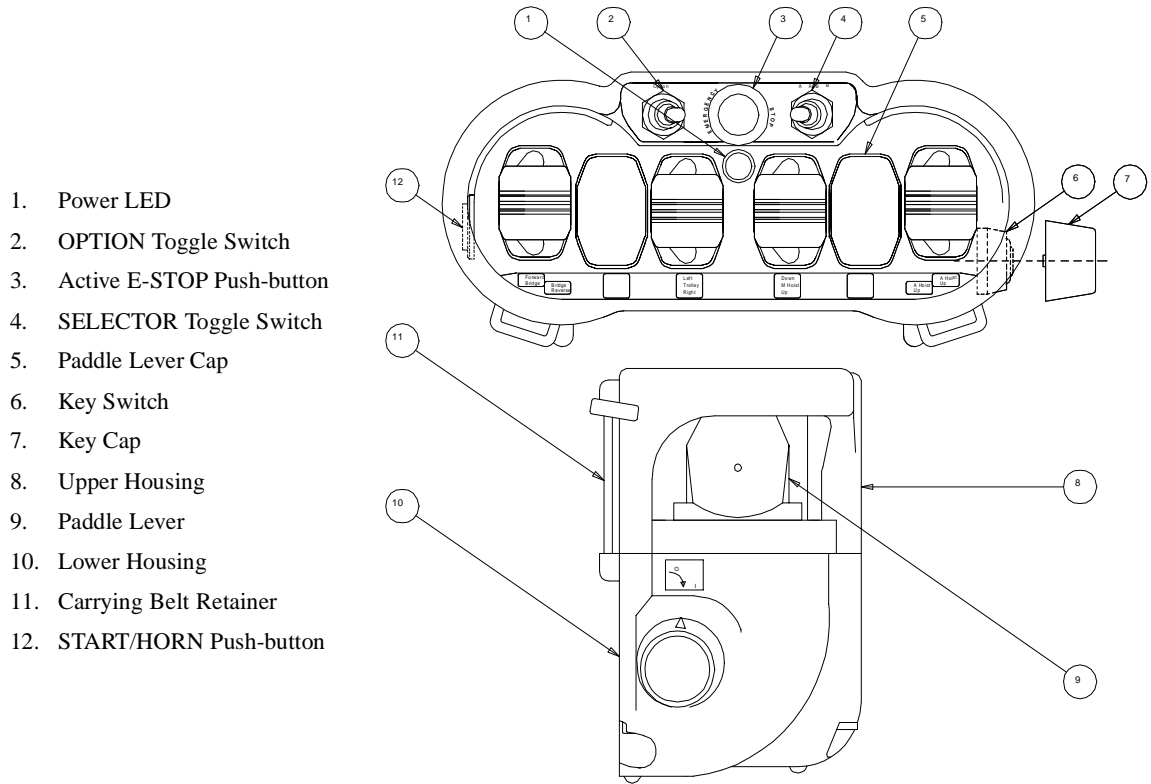

*Figure 3.4: NVT Paddle Lever Transmitter Layout*

## NVT Transmitter Functions

The following describes the basic functionality of the NVT transmitter. Please reference Figure 3.3: NVT Joystick Transmitter Layout or Figure 3.4: NVT Paddle Lever Transmitter Layout for the location of these functions.

**START/HORN Push-Button.** The **START/HORN** push-button activates the mainline contactor and sounds the horn (when provided). Once the mainline contactor has been turned on, pressing this push-button sounds the horn only (when provided).

**Active E-STOP Push-button.** Pressing the **Active E-STOP** push-button will turn off the mainline contactor. The **Active E-STOP** push-button must be pulled out for the transmitter to control the crane motions.

**NOTE:** *The Active E-STOP push-button is for emergency situations only. Do NOT use it as an Off switch. Use the key switch to turn the transmitter on and off.*

**Power LED.** As soon as the NVT is turned on, this light will flash once. The transmitter then goes through a diagnostic check. If the transmitter passes the diagnostic check the Power LED flashed green. This indicates that the transmitter is powered up.

**Key Switch.** The key switch turns the transmitter on and off. It only works with the key cap inserted, and the key cap can only be removed while in the OFF position.

**Joysticks.** The standard NVT joysticks provide stepless proportional speed control without detents of up to four crane motions. The number of motions can be increased by using the **SELECTOR** toggle switch for independent/combined control of cranes or trolley/hoists. Other joysticks are available that offer three-step speed control with detents.

**NOTE:** *The five, six, and seven-motion NVT transmitters use two joysticks and a three-position **SELECTOR** toggle switch for independent and combined control of multi-motions.*

**Paddle Levers.** The standard NVT paddle lever provide stepless proportional speed control without detents of up to six crane motions. The number of motions can be increased by using the **SELECTOR** toggle switch for independent/combined control of cranes or trolley/hoists.

**OPTION Toggle Switch.** This switch controls the **OPTION** function connected to the PulseStar•610 receiver (lights, for example). The function will begin when the switch is moved to the On position. The function will continue working until the switch is moved to the Off position.

**SELECTOR Toggle Switch.** The **SELECTOR** toggle switch allows the operator to control multiple cranes from a single transmitter, or multiple crane motions from a single joystick or paddle lever. When the **SELECTOR** toggle switch is set to A, the transmitter controls the crane or motion(s) which are designated as A. When the **SELECTOR** toggle switch is set to B, the transmitter controls the crane or motion(s) which are designated as B. When the **SELECTOR** toggle switch is set to A+B, both A and B cranes or motions are controlled by the transmitter.

## GLT Transmitter

The GLT transmitter has a “belly box” design where the operator maneuvers joysticks or paddle levers to control crane motions. The standard GLT joysticks and paddle levers offer proportional speed control without detents. Joysticks are available which provide up to six speeds with detents. The GLT joystick model can contain up to three dual axis joysticks for up to six motion control. The GLT paddle lever model can contain up to seven single axis paddle levers for up to seven motion control.

The GLT also offers a **SELECTOR** toggle switch for controlling multiple crane motions with one joystick or paddle lever. With the **SELECTOR** toggle switch, the GLT can control up to nine crane motions for independent/combined control.

### GLT Transmitter Components (Joystick Model)

The GLT joystick transmitter has the following components. Refer to Figure 3.5: GLT Joystick Transmitter Layout to identify parts of the GLT transmitter.

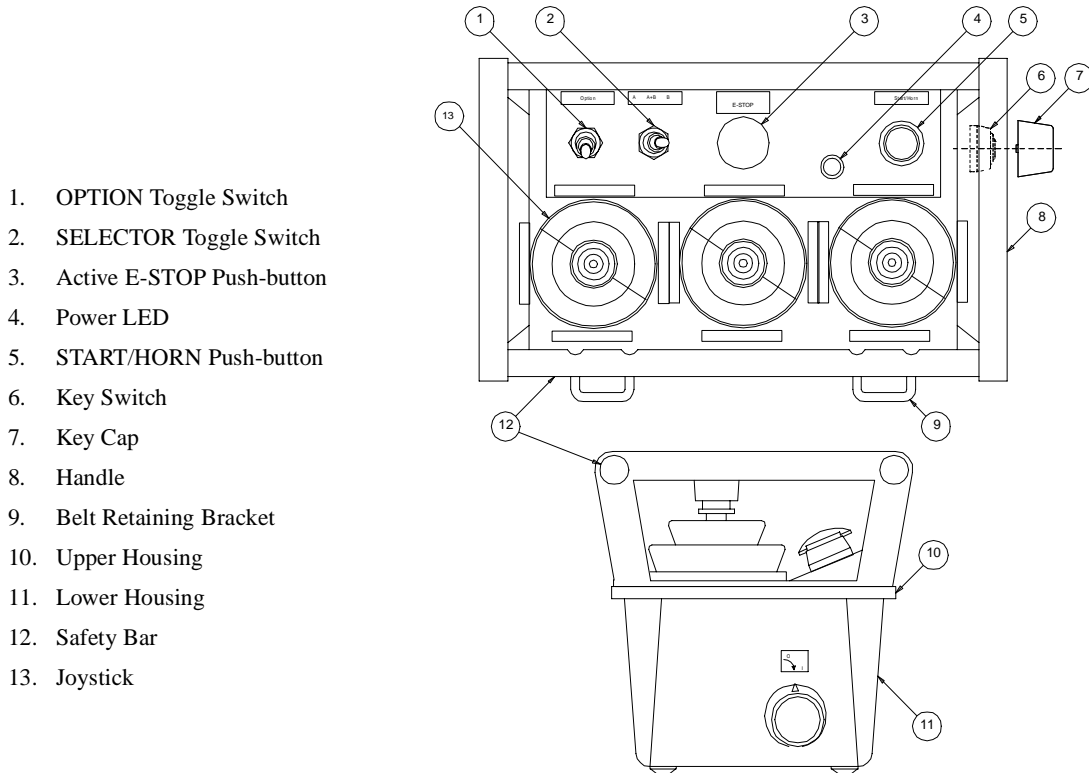

*Figure 3.5: GLT Joystick Transmitter Layout*

## GLT Transmitter Components (Paddle Lever Model)

The GLT paddle lever transmitter has the following components. Refer to Figure 3.6: GLT Paddle Lever Transmitter Layout to identify parts of the GLT transmitter.

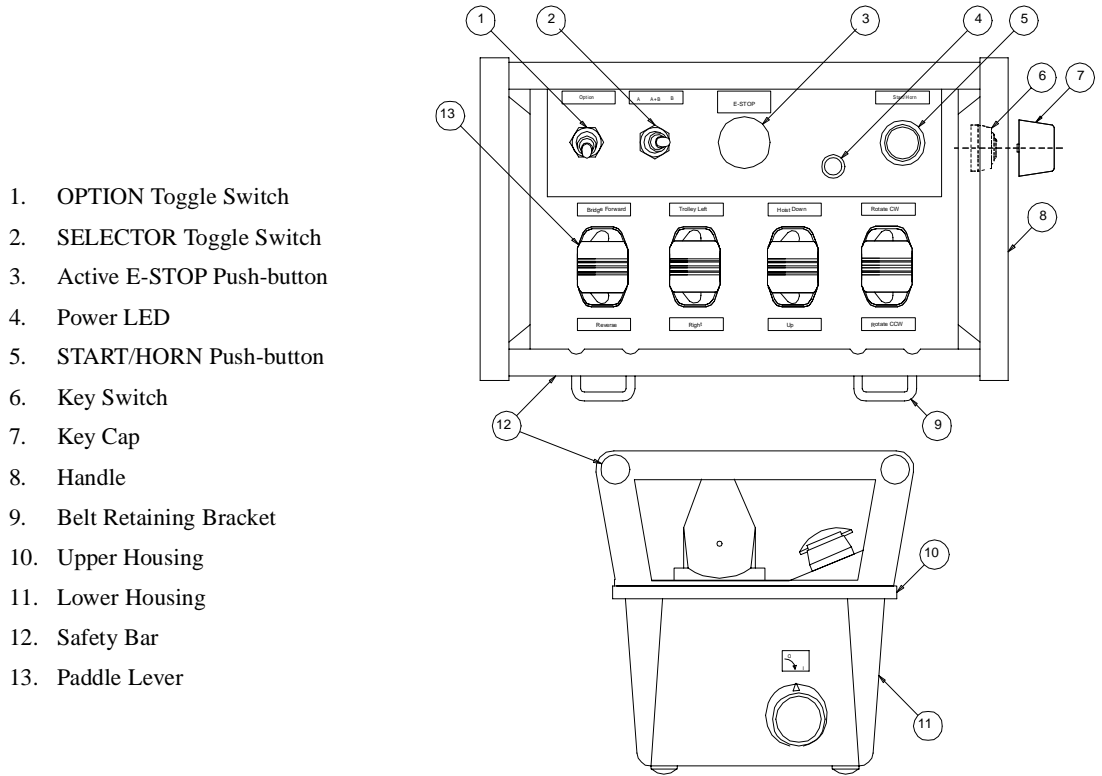

*Figure 3.6: GLT Paddle Lever Transmitter Layout*

## GLT Transmitter Functions

The following describes the basic functionality of the GLT transmitter. Please reference for the location of these functions.

**START/HORN Push-button.** The **START/HORN** push-button activates the mainline contactor and sounds the horn (when provided). Once the mainline contactor has been turned on, pressing this push-button sounds the horn only (when provided).

**Active E-STOP Push-button.** Pressing the **Active E-STOP** push-button will turn off the mainline contactor. The **Active E-STOP** push-button must be pulled out for the transmitter to control the crane motions.

**NOTE:** *The Active E-STOP push-button is for emergency situations only. Do NOT use it as an Off switch. Use the key switch to turn the transmitter on and off.*

**Power LED.** As soon as the NVT is turned on, this light will flash once. The transmitter then goes through a diagnostic check. If the transmitter passes the diagnostic check the Power LED flashed green. This indicates that the transmitter is powered up.

**Key Switch.** The key switch turns the transmitter on and off. It only works with the key cap inserted, and the key cap can only be removed while in the OFF position.

**Joysticks.** The standard GLT joysticks provide stepless proportional speed control without detents of up to six crane motions. This number of motions can be increased by using the **SELECTOR** toggle switch for independent/combined control of cranes or trolley/hoists. Other models are available that offer six-step speed control with detents.

**NOTE:** *The five, six, seven, and nine-motion GLT transmitters use two or three joysticks and a three-position SELECTOR toggle switch for independent and combined control of multi-motions.*

**Paddle Levers.** The standard GLT paddle lever provide stepless proportional speed control without detents of up to seven crane motions. The number of motions can be increased by using the **SELECTOR** toggle switch for independent/combined control of cranes or trolley/hoists.

**OPTION Toggle Switch.** This switch controls the **OPTION** function connected to the PulseStar•610 receiver (lights, for example). The function will begin when the switch is moved to the On position. The function will continue working until the switch is moved to the Off position.

**SELECTOR Toggle Switch.** The **SELECTOR** toggle switch allows the operator to control multiple cranes from a single transmitter, or multiple crane motions from a single joystick or paddle lever. When the **SELECTOR** toggle switch is set to A, the transmitter controls the crane or motion(s) which are designated as A. When the **SELECTOR** toggle switch is set to B, the transmitter controls the crane or motion(s) which are designated as B. When the **SELECTOR** toggle switch is set to A+B, both A and B cranes or motions are controlled by the transmitter.

## GRT Transmitter

The GRT transmitter has a “belly box” design where the operator maneuvers joysticks or paddle levers to control crane motions. The standard GRT joysticks and paddle levers offer proportional speed control without detents. Joysticks are available which provide up to six speeds with detents. The GRT joystick model can contain up to three dual axis joysticks for up to six motion control. The GRT paddle lever model can contain up to seven single axis paddle levers for up to seven motion control.

The GRT also offers a **SELECTOR** toggle switch for controlling multiple crane motions with one joystick or paddle lever. With the **SELECTOR** toggle switch, the GRT can control up to nine crane motions for independent/combined control.

### GRT Transmitter Components

The GRT transmitter has the following components. Refer to Figure 3.7: GRT Transmitter Layout (Top View) and Figure 3.8: GRT Transmitter Layout (Side View) to identify parts of the GRT transmitter.

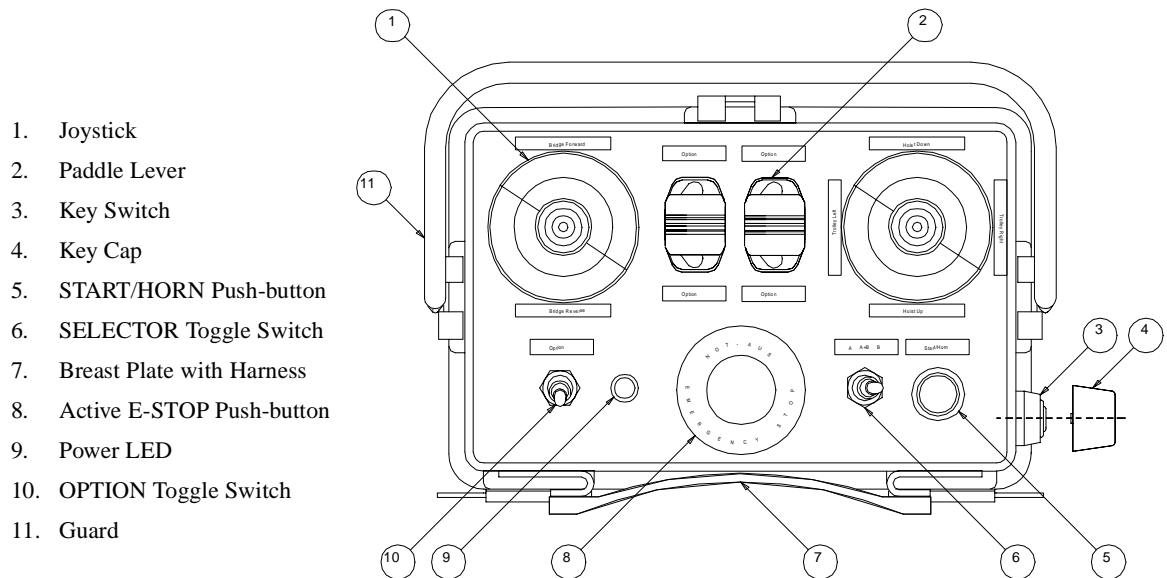
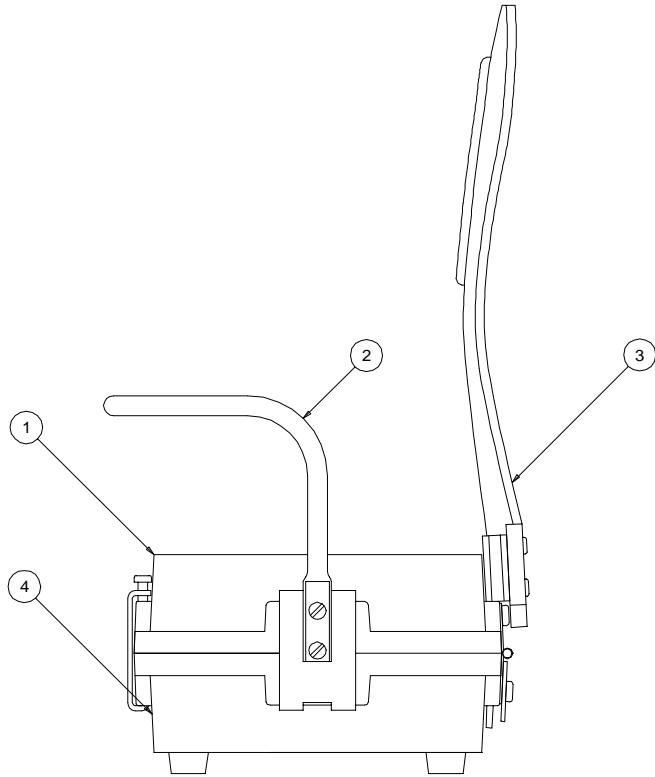

Figure 3.7: GRT Transmitter Layout (Top View)

1. Upper Housing
2. Guard
3. Breast Plate with Harness
4. Lower Housing



*Figure 3.8: GRT Transmitter Layout (Side View)*

## GRT Transmitter Functions

The following describes the basic functionality of the GRT transmitter. Please reference for the location of these functions.

**START/HORN Push-button.** The **START/HORN** push-button activates the mainline contactor and sounds the horn (when provided). Once the mainline contactor has been turned on, pressing this push-button sounds the horn only (when provided).

**Active E-STOP Push-button.** Pressing the **Active E-STOP** push-button will turn off the mainline contactor. The **Active E-STOP** push-button must be pulled out for the transmitter to control the crane motions.

**NOTE:** *The Active E-STOP push-button is for emergency situations only. Do NOT use it as an Off switch. Use the key switch to turn the transmitter on and off.*

**Power LED.** As soon as the NVT is turned on, this light will flash once. The transmitter then goes through a diagnostic check. If the transmitter passes the diagnostic check the Power LED flashed green. This indicates that the transmitter is powered up.

**Key Switch.** The key switch turns the transmitter on and off. It only works with the key cap inserted, and the key cap can only be removed while in the OFF position.

**Joysticks.** The standard GRT joysticks provide stepless proportional speed control without detents of up to six crane motions. The number of motions can be increased by using the **SELECTOR** toggle switch for independent/combined control of cranes or trolley/hoists. Other models are available that offer six-step speed control with detents.

**NOTE:** *The five, six, seven, and nine-motion GRT transmitters use two or three joysticks and a three-position SELECTOR toggle switch for independent and combined control of multi-motions.*

**Paddle Levers.** The standard GRT paddle lever provide stepless proportional speed control without detents of up to seven crane motions. The number of motions can be increased by using the **SELECTOR** toggle switch for independent/combined control of cranes or trolley/hoists.

**OPTION Toggle Switch.** This switch controls the **OPTION** function connected to the PulseStar•610 receiver (lights, for example). The function will begin when the switch is moved to the On position. The function will continue working until the switch is moved to the Off position.

**SELECTOR Toggle Switch.** The **SELECTOR** toggle switch allows the operator to control multiple cranes from a single transmitter, or multiple crane motions from a single joystick or paddle lever. When the **SELECTOR** toggle switch is set to A, the transmitter controls the crane or motion(s) which are designated as A. When the **SELECTOR** toggle switch is set to B, the transmitter controls the crane or motion(s) which are designated as B. When the **SELECTOR** toggle switch is set to A+B, both A and B cranes or motions are controlled by the transmitter.

# Transmitter Setup

This section covers how to set up a PulseStar•610 transmitter.

## Placing the Push-button Labels

If your new, spare or replacement JRT or PBT transmitter came with push-button legends that you need to insert, refer to Figure 3.9: PBT Transmitter Label Insertion and the following instructions. The same procedure can be used with the JRT transmitter. Do not operate the transmitter until all legends are properly installed.

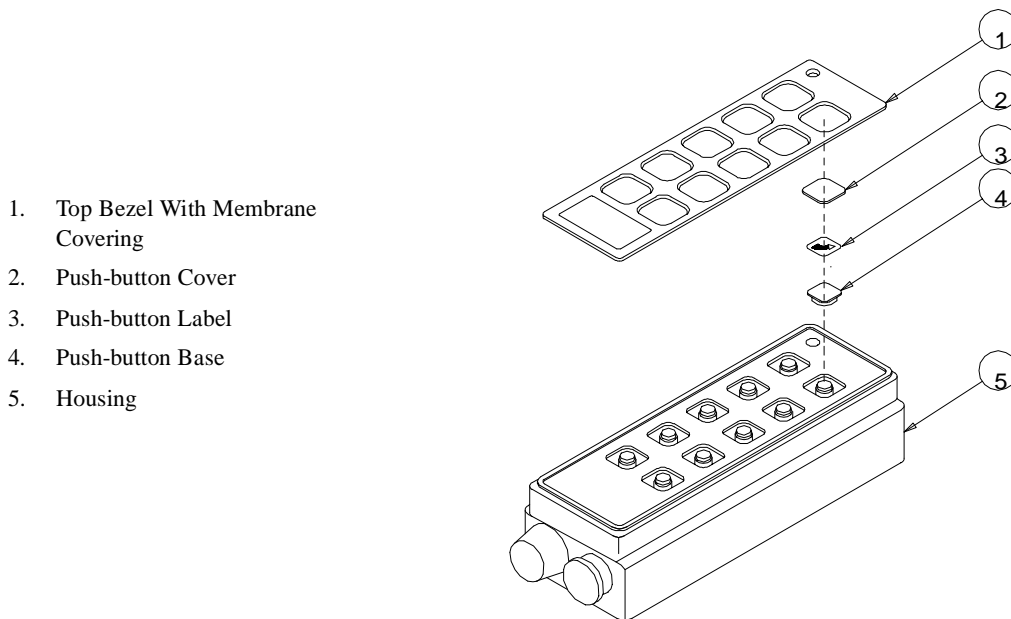

*Figure 3.9: PBT Transmitter Label Insertion*

1. Unsnap the push-button cover from the push-button base. Remove the push-button label and replace it with the new label. Place the label in the push-button cover face down so that when you turn the push-button over, the push-button label is visible.
2. Snap the push-button base into the cover. Repeat steps 1 and 2 for each push-button label you are replacing.
3. Assemble the push-buttons on the transmitter according to the layout for your application.
4. Ensure that the transmitter housing is free of dirt, oil and other contaminants or the bezel with membrane covering won't stick. Use rubbing alcohol to clean any dirt or oils which may be present.
5. Once you are satisfied with the push-button layout, remove the adhesive strip on the back of the bezel with membrane covering and line it up on the enclosure. Press the bezel firmly into place.

**NOTE:** *DO NOT use any glues or adhesives to affix the bezel with membrane covering to the transmitter housing. Doing this can permanently damage the transmitter, and will void the warranty.*

## Transmitter Address Code and Frequency Channel

This section explains how to set the address code and frequency channel of the PulseStar•610 transmitter. The PulseStar•610 address code and frequency channel are configured at the factory. This should be done ONLY if you are setting up a spare or replacement transmitter, or directed to do so by Electromotive Systems.



### WARNING

- Do NOT change the address code or frequency channel of the original PulseStar•610 transmitter that came with your PulseStar•610 system without first contacting Electromotive Systems.
- Do NOT change the address code settings in the receiver.
- Do NOT operate two transmitters set with the same frequency channel and address code as the receiver at the same time.

### Serial Nameplate

The transmitter serial nameplate is located on one of the side walls of the PulseStar•610 transmitter battery cavity. The serial nameplate contains the Electromotive Systems job number, the address code used by the system, and the frequency channel used by the system. **The Electromotive Systems job number is important if you ever need to call Electromotive Systems for service.** Please have this information available when contacting Electromotive Systems.

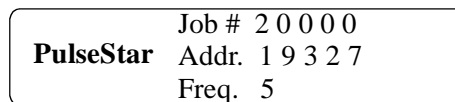

*Figure 3.10: Serial Nameplate*

## Setting the Address Code and Frequency Channel of a Transmitter:



### CAUTION

*Before working on the transmitter, remove the battery.*

Before setting the address code and frequency channel of the transmitter, ensure you first know the address code and frequency channel of the receiver it is going to control. This information can be found by locating the serial nameplate on the PulseStar•610 receiver. Refer to the Serial Nameplate section in chapter 2 for the location of the receiver serial nameplate.

1. Make sure the transmitter is off. Remove the key to be sure.
2. Remove the battery from the transmitter, refer to Battery and Charger Information later in this chapter.
3. Access the inside of the PulseStar•610 transmitter.
  - For the JRT transmitter remove the screws on the back of the JRT transmitter that fastens the back plate to the housing and remove back plate.
  - For the PBT, NVT, GLT and GRT transmitter remove the four screws which hold the upper housing and lower housing together.
4. Locate the two blocks of address code DIP switches on the transmitter coder board, and the frequency channel jumper block on the RF module inside the PulseStar•610 transmitter.

### Determining the Address Code

Refer to Figure 3.11: JRT Coder Board Layout, Figure 3.12: PBT Coder Board Layout, or Figure 3.13: NVT, GLT, GRT Coder Board Layout for typical transmitter coder boards, and the location of the address code dip switches.

The address code is a 16 bit binary number which is assigned to each PulseStar system. This code ensures that no other PulseStar system or other radio controlled device can accidentally operate the crane. The address code number on the serial nameplate is a decimal equivalent to the binary code assigned to the system. To determine the binary code of your PulseStar system you can do one of the following:

- Using a calculator with decimal to binary conversion, enter the decimal address code number from the serial nameplate on the receiver. Then convert this number to its binary equivalent.
- Record the 16 address code switch positions inside the receiver. All switches are either 'on' or 'off'. Always read the switches with the numbering and lettering right side up, from left to right, and with switch number one being on the left.
- Consult Electromotive Systems for information concerning your address code.

Once you have the correct address code information you can configure the transmitter to work with the existing receiver.

## Setting the Address Code

Reference Figure 3.11: JRT Coder Board Layout for changing the address for a JRT transmitter, Figure 3.12: PBT Coder Board Layout for changing the address for a PBT transmitter, or Figure 3.13: NVT, GLT, GRT Coder Board Layout for changing the address for a NVT, GLT, or GRT transmitter.



### WARNING

- Do NOT change the address code or frequency channel of the original PulseStar•610 transmitter that came with your PulseStar•610 system without first contacting Electromotive Systems.
- Do NOT change the address code settings in the receiver.
- Do NOT operate two transmitters set with the same frequency channel and address code as the receiver at the same time.

1. Orientate the address code switches so that the numbering and lettering is right side up.
2. Locate switch 1 on the left most block of the address code switches. This switch is the first bit of the binary address code.
3. Set each switch to either 'on' or 'off' according the binary address code information.
4. If you do not have to set the frequency channel you can now close the transmitter by placing the back plate in place and inserting the screws for the JRT transmitter, or by mating the lower and upper halves and inserting the four screws for the PBT, NVT, GLT and GRT transmitter.

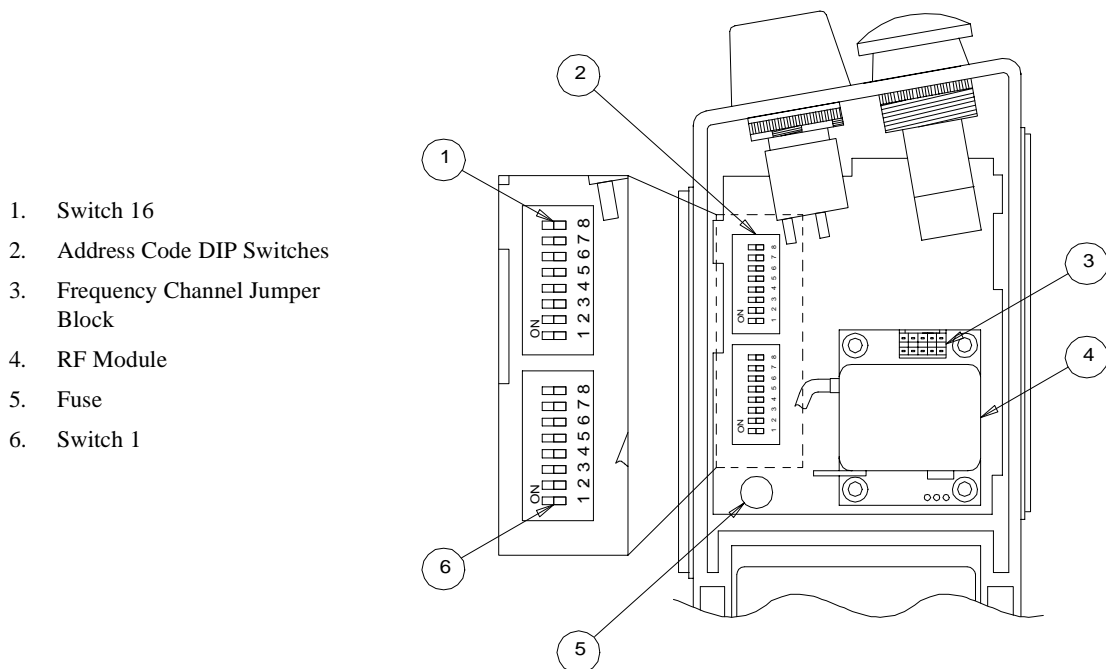

*Figure 3.11: JRT Coder Board Layout*

1. Switch 1
2. Fuse
3. Address Code DIP Switches
4. Coder Board for PBT
5. Switch 16

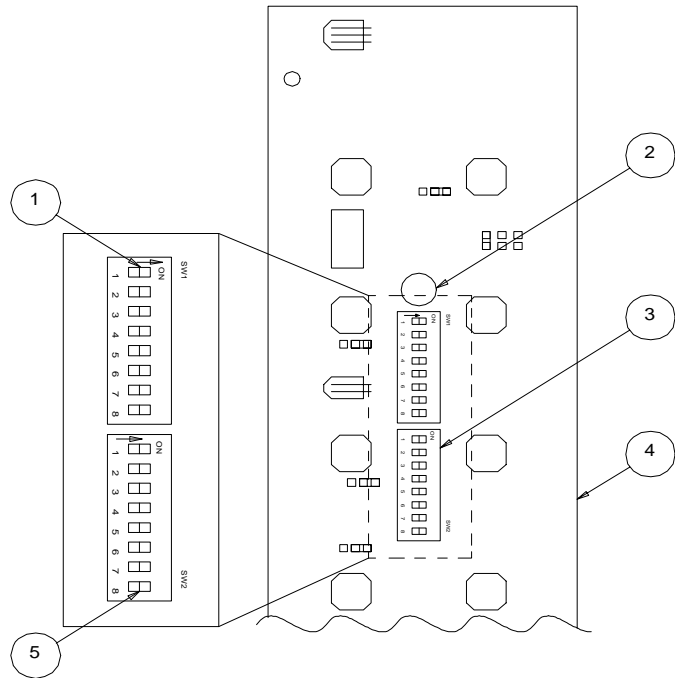

**Figure 3.12: PBT Coder Board Layout**

1. Analog Signal Connector
2. Fuse
3. Coder Board For NVT, GLT, GRT
4. Address Code DIP Switches
5. Switch 16
6. Switch 1
7. Multi-pin Connector

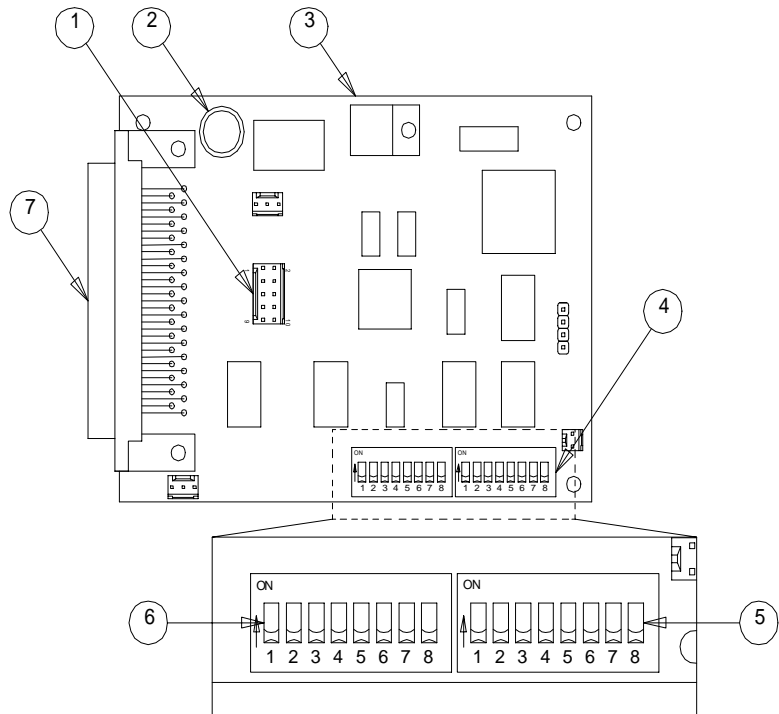
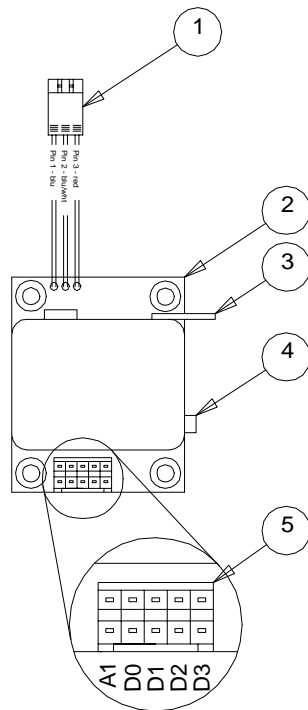

**Figure 3.13: NVT, GLT, GRT Coder Board Layout**

## Setting the Frequency Channel

The frequency channel of the transmitter must be set to the frequency channel of the receiver it is going to control. The transmitter and receiver operate over the 400–470 MHz frequency range (70-cm band). There are 16 possible frequency channels. Figure 3.14: Frequency Diagram shows the transmitter RF Module, and each channel, its respective frequency, and the position of the five jumpers.

1. Locate the RF Module inside the transmitter.
2. Locate the Frequency Channel Jumper Block on the RF Module. Orientate the transmitter so that the A1 jumper position is on your left-hand side.
3. Set the frequency jumpers according to the diagram for the desired frequency. A black box indicates that a jumper should be present in that position. A white box indicates there should be no jumper present in that position.
4. When finished, close the transmitter by placing the back plate in place and inserting the screws for the JRT transmitter, or by mating the lower and upper halves and inserting the four screws for the PBT, NVT, GLT and GRT transmitter.



Channel	A1	D0	D1	D2	D3	Frequency
0	■	■	■	■	■	458.800 MHz
1	■	□	■	■	■	458.825 MHz
2	■	■	□	■	■	458.850 MHz
3	■	□	□	■	■	458.875 MHz
4	■	■	■	□	■	458.900 MHz
5	■	□	■	□	■	458.925 MHz
6	■	■	□	□	■	458.950 MHz
7	■	□	□	□	■	458.975 MHz
8	■	■	■	■	□	459.000 MHz
9	■	□	■	■	□	459.025 MHz
10	■	■	□	■	□	459.050 MHz
11	■	□	□	■	□	459.075 MHz
12	■	■	■	□	□	459.100 MHz
13	■	□	■	□	□	459.125 MHz
14	■	■	□	□	□	459.150 MHz
15	■	□	□	□	□	459.175 MHz

■ Jumper is present

□ Jumper is not present

Figure 3.14: Frequency Diagram

- |                     |                                   |
|---------------------|-----------------------------------|
| 1. TTL Connector    | 4. Antenna Connector              |
| 2. RF Module        | 5. Frequency Channel Jumper Block |
| 3. Ground Connector |                                   |

# Start-up and Operation

## Holding the Transmitter

Before using the PulseStar•610 transmitter, refer to the following information on how to hold the PulseStar•610 transmitter the correct way.



### WARNING

To make sure that you are oriented correctly in relation to the directional push-buttons, paddle levers or joysticks. Hold the transmitter as shown.

### JRT Transmitter

Please refer to Figure 3.15: JRT Transmitter Orientation on how to properly hold the JRT transmitter.

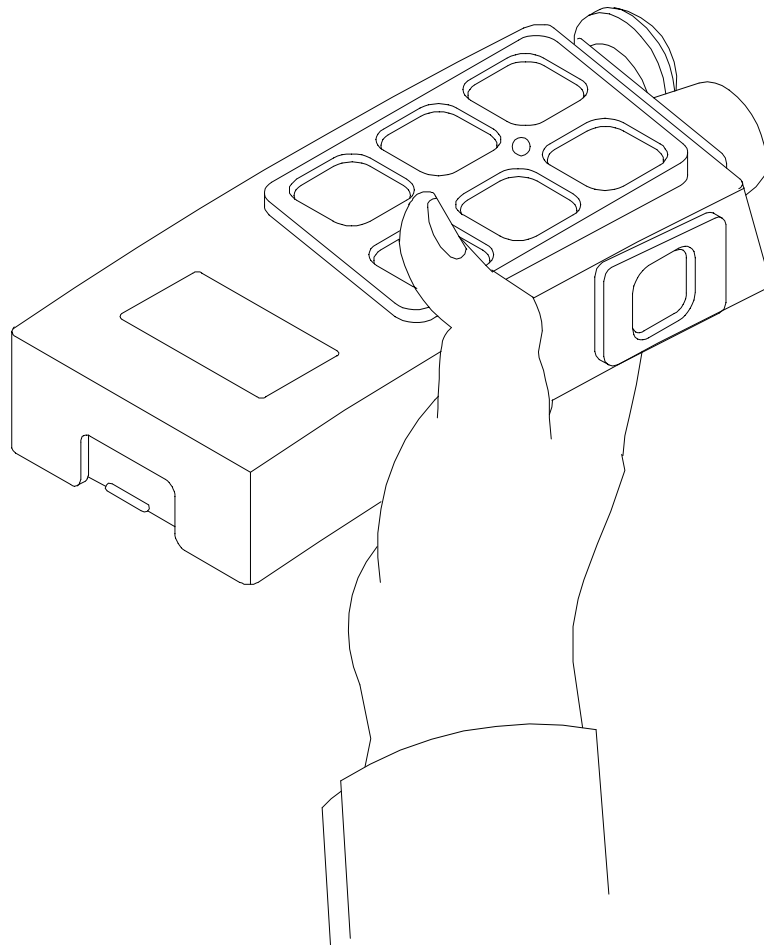

*Figure 3.15: JRT Transmitter Orientation*

## **PBT Transmitter**

Please refer to Figure 3.16: PBT Transmitter Orientation on how to properly hold the PBT transmitter.

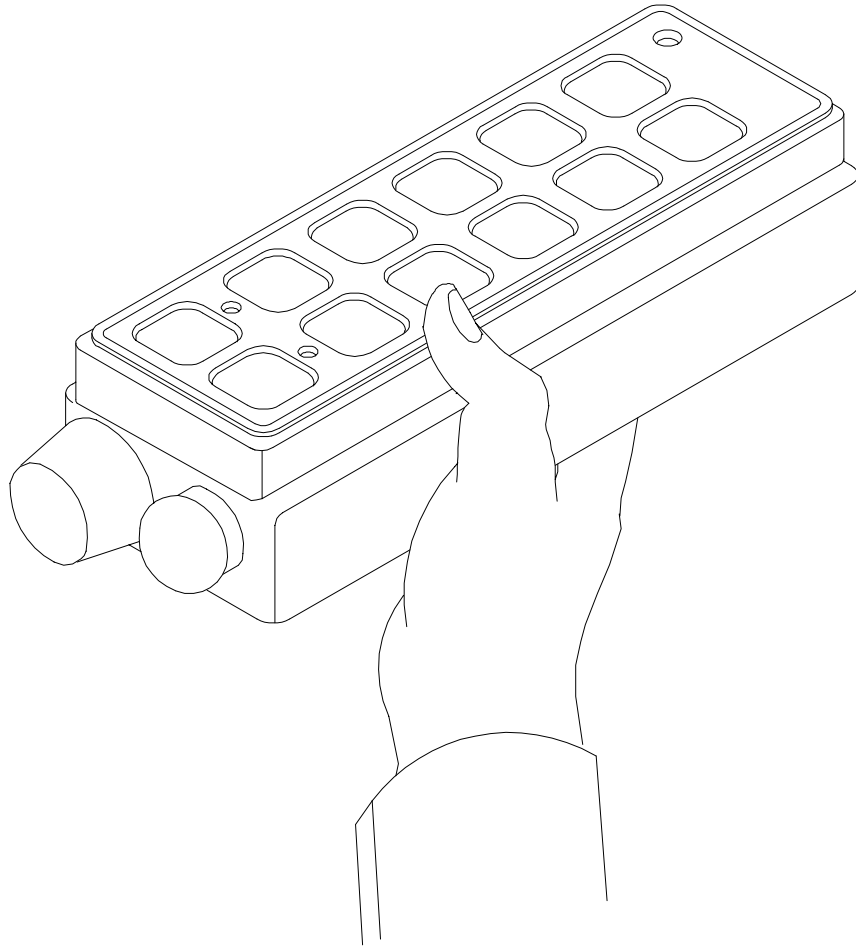

*Figure 3.16: PBT Transmitter Orientation*

## NVT Transmitter

Please refer to Figure 3.17: NVT Transmitter Orientation on how to properly hold the NVT transmitter.

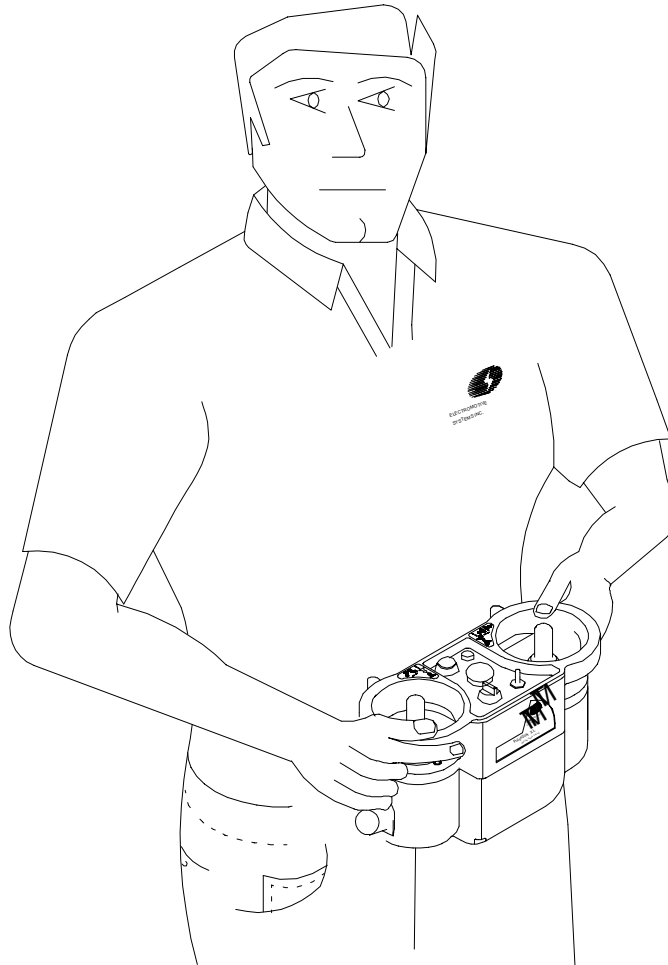

*Figure 3.17: NVT Transmitter Orientation*

## GLT Transmitter

Please refer to Figure 3.18: GLT Transmitter Orientation on how to properly hold the GLT transmitter.

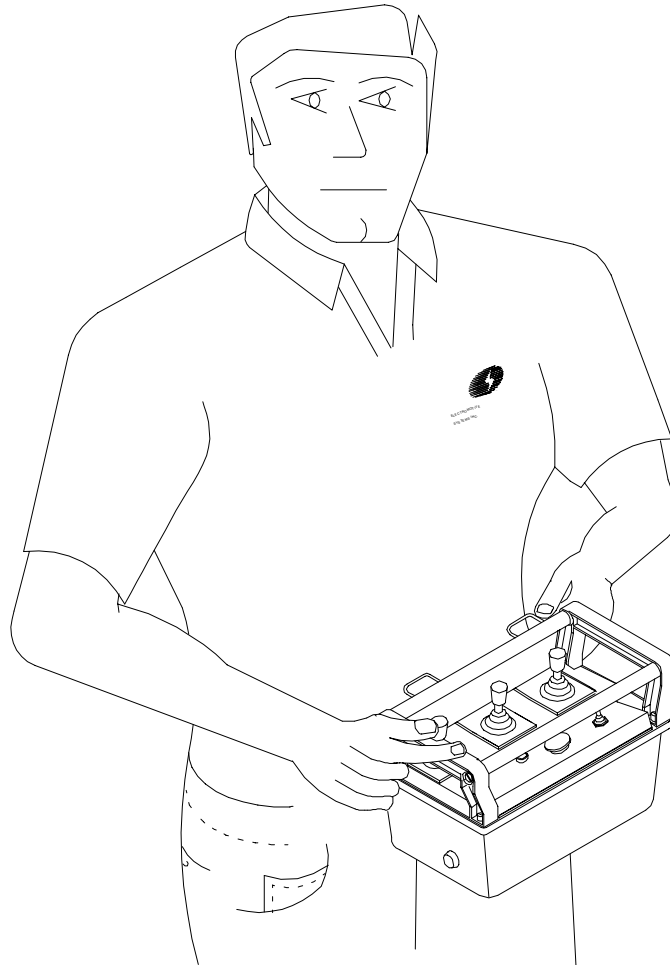

*Figure 3.18: GLT Transmitter Orientation*

## GRT Transmitter

Please refer to Figure 3.19: GRT Transmitter Orientation on how to properly hold the GRT transmitter.

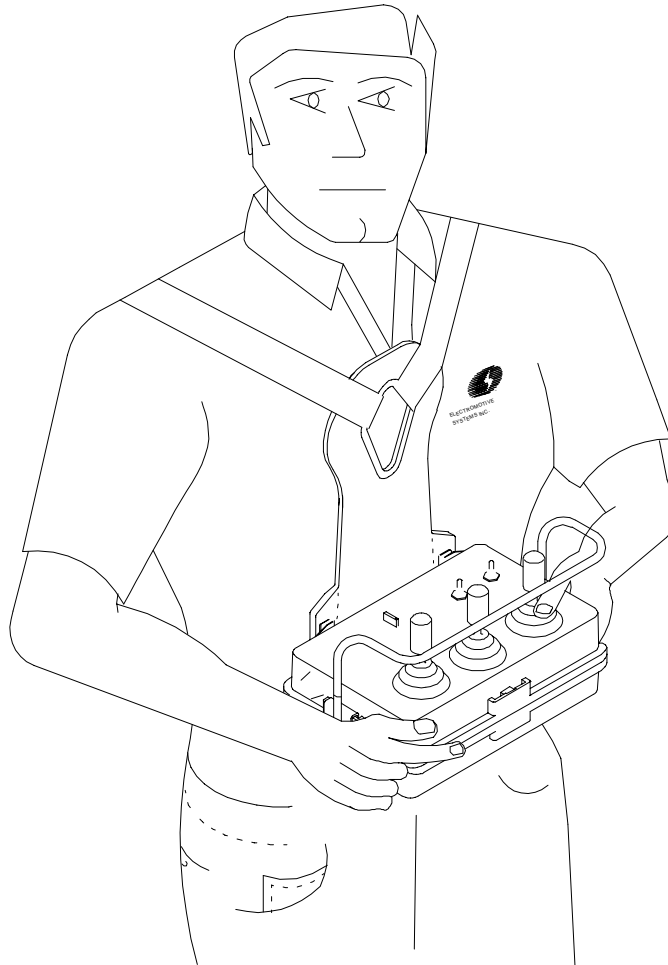

*Figure 3.19: GRT Transmitter Orientation*

## Start-up

Refer to the appropriate transmitter layout figure shown in PulseStar•610 Transmitters section for the location of the various functions on the PulseStar•610 transmitter. To start the PulseStar•610 transmitter:

1. Make sure that there is a charged battery in the transmitter.
2. Make sure the **Active E-STOP** push-button is pressed in.
3. Make sure no motion push-buttons are depressed (JRT, PBT) or all joysticks or paddle levers are in the center (off) position (NVT, GLT and GRT transmitters).
4. Insert the key into the key switch and turn to the ON position. The power LED flashes to indicate power is on. NVT, GLT and GRT models will emit two sounds. The first sound indicates that the transmitter is going through the diagnostic check. The second sound indicates that the transmitter has passed the diagnostic check.
5. Pull out the **Active E-STOP** push-button and press the **START/HORN** push-button to provide power to the mainline contactor.

The transmitter is now ready for use.

## Emergency Stop

For all emergency situations, push in the **Active E-STOP** push-button. To restart, pull out the **Active E-STOP** push-button and press the **START/HORN** push-button.

When the PulseStar•610 battery voltage drops below approximately 8 volts, the power LED on the transmitter will begin flashing red for about 30 seconds for the JRT model, and a buzzer will sound for PBT, NVT, GLT, and GRT transmitters. At the end of the 30 second period, the transmitter will automatically shut itself off and places the receiver in **Safe Mode**. This blocks all crane motion commands.

## Using the Motion Push-buttons (JRT and PBT)

The JRT transmitter can control up to three crane motions. The PBT transmitter can control up to four crane motions. Each pair of push-buttons corresponds to one crane motion. The push-buttons are “interlocked,” which means that only one push-button in each horizontal row is operational at a time. In other words, if you press a push-button, the crane function corresponding to that push-button will be activated. If you then press the other push-button in the same row while still holding down the first push-button pressed, the receiver will ignore the crane motion corresponding to the second push-button pressed.

## Using the Joysticks and/or Paddle Levers (NVT, GLT and GRT)

All joysticks and paddle levers have a spring return to the center (off) position. Locate the transmitter label which corresponds to the joystick or paddle lever function you wish to operate. Deflect the joystick or paddle lever in the direction you want the crane motion to move according to the label. If the crane motion is more than one speed, the further you deflect the joystick or paddle lever from its center position, the faster the crane motion will move. To stop the crane motion(s) simply return the joystick or paddle lever to the center (off) position.

## **Optional Switches and Push-buttons**

Depending on the application, PulseStar•610 transmitter can be provided with an assortment of rotary switches, toggle switches, or push-buttons. These functions will be labeled according to what they are controlling. Typically it is necessary to position the switch to the proper location according to transmitter labeling to operate that specific function. If you are unsure how to correctly operate these switches, Consult Electromotive Systems for a detailed description on how to use them.

## **Shutting Off the Transmitter**

When you are finished using the transmitter, turn the key switch to OFF. The mainline contactor will drop out. Remove the key switch and take it with you to prevent unintended use.

# Transmitter Options

All PulseStar•610 transmitters are engineered to order. Because of this you may have features and functionality which are not covered in the PulseStar•610 manual. The following are some of the more common options which are available with the PulseStar•610 transmitter. If you have any questions about the functionality of your PulseStar•610 system contact Electromotive Systems.

## Spare Transmitter

Spare transmitters can be used in the event that the primary transmitter becomes lost or damaged. One transmitter is used as the main crane control and the other is designated as a spare. Only one transmitter is active at any given time.

**NOTE:** *If both transmitters are set to the same frequency and address, and both transmitters are turned on, the receiver will go into Safe Mode.*

## Address Plugs

For applications where several PulseStar•610 systems are used, address plugs can be used to configure a spare transmitter to be used on any of the cranes. Simply place the address plug corresponding to that specific crane into the address plug receptacle, and the spare transmitter is now configured to operate that crane.

## Crane Control Using Multiple Transmitters

Several crane applications require the use of more than one transmitter, or a transmitter may be required to control several cranes simultaneously.

### Pitch and Catch

Pitch and catch is where multiple (typically two) transmitters control the same receiver, but not at the same time. This is ideal for applications with long crane bays where control of the crane will be handed off to another operator, or where restricted visibility makes it necessary for more than one operator to position the load.

- All transmitters must be configured with the same address code as the receiver
- Each transmitter must be set to a different frequency channel.
- The receiver must be configured for **AutoScan**.

The first transmitter to be turned on will control the crane. An operator moves the load with this transmitter to a specific location and then switches the transmitter off. A second operator switches their transmitter on and presses the **START/HORN** push-button. The second operator then takes over control of the crane the rest of the way. If a transmitter is turned on while the other transmitter is controlling the crane, the receiver ignores the signal from the transmitter which was turned on last.

### Independent/Combined Control of Multiple Cranes

In this situation there are multiple cranes (typically two) on a single runway. Each crane is independently controlled at the same time, but occasionally these cranes are operated in tandem by a single operator. Transmitter interlocking is typically used to accomplish this.

Interlocking is where each transmitter is set up with a different address code and frequency channel. Instead of using **AutoScan** in the receiver, the receiver has a RF module and decoder set for each transmitter which can be used to control the cranes. A special module inside the receiver determines which transmitter is requesting control of each specific crane. This module then 'locks' control of that particular crane to the transmitter, and all other transmitters are ignored.

Transmitters used for these applications are provided with **SELECTOR** switches which can select each crane individually, or can select multiple cranes. Simply move the **SELECTOR** switch to the position which matches how many cranes you want to control.

Crane control can be relinquished by turning off the transmitter which is controlling the crane(s). Turning off the transmitter makes the crane(s) previously selected available to be controlled by another transmitter.

## **Safety Devices**

Additional features can be incorporated into the PulseStar•610 transmitter to increase the safety level of operation.

### **Press To Operate Safety Switch**

When controlling the dropping of loads with the PulseStar•610 transmitter it is necessary to incorporate two-handed operation by means of a Press To Operate (PTO) Safety Switch. The PTO switch must be activated simultaneously with the load drop switch in order to release the load. Common applications for PTO switches are magnet control systems, vacuum lifter systems, and grabs. If desired any crane motion can be provided with PTO control.

### **Lift To Operate Joysticks**

GLT and GRT transmitters can be provided with Lift To Operate (LTO) joysticks. A safety device located near the top of the joystick handle must be grasped and lifted toward the top of the joystick handle in order to operate the joystick.

### **Lift To Operate Toggle Switches**

NVT, GLT and GRT transmitter can be provided with Lift To Operate (LTO) toggle switches. These toggle switches must be lifted out of their home position in order to be moved to the 'on' position. LTO toggle switches can be maintained or spring return to center (momentary).

### **Tilt Switches**

GLT and GRT transmitters can be equipped with mercury tilt switches. If the transmitter is tilted more than 30 degrees or 45 degrees from level, the tilt switch activates, and the transmitter sends an **Active E-STOP** signal to the receiver, placing it in **Safe Mode**.

## Free Channel Search

All PulseStar•610 transmitters except the JRT transmitter can be provided with **Free Channel Search**. **Free Channel Search** is a module located inside the transmitter which works with the RF module to find a frequency channel which is suitable for broadcasting. **Free Channel Search** is ideal for environments which have a large amount of RF interference caused by equipment broadcasting in the same frequency range as the PulseStar•610 system

When the transmitter is turned on, the **Free Channel Search** module begins to scan the environment for interference. The **Free Channel Search** module can be configured to scan all 16 frequency channels, or just the odd or even frequency channels. Scanning all 16 frequency channels takes approximately 3 seconds. The PulseStar•610 receiver must be configured for **AutoScan** to use **Free Channel Search**.

When activated the **Free Channel Search** module starts at frequency channel 0 (even or sixteen frequency channel mode) or frequency channel 1 (odd frequency channel mode) and determines if that frequency channel is clear for communicating with the receiver.

If the frequency channel is clear for communications, the transmitter locks on to that frequency channel, and begins transmitting information to the receiver. If there is interference on that frequency channel, the **Free Channel Search** module goes to the next frequency channel until it finds a clear channel.

If interference begins to affect crane operation, simply cycle transmitter power (turn off and back on again). **Free Channel Search** finds another frequency channel to broadcast on which is free from interference.

**NOTE:** *Not all applications are appropriate for Free Channel Search. Consult Electromotive Systems and discuss your application prior to using Free Channel Search.*

### Setting the Odd/Even Channel Search of the Free Channel Search Function



#### WARNING

- Do NOT change the address code or frequency channel of the original PulseStar•610 transmitter that came with your PulseStar•610 system without first contacting Electromotive Systems.
- Do NOT change the address code settings in the receiver.
- Do NOT operate two transmitters set with the same frequency channel and address code as the receiver at the same time.

If you ordered you PulseStar•610 system with the **Free Channel Search** feature, the transmitter automatically begins broadcasting on the first available clear channel when turned on. You can control which frequency channels the transmitter searches through (odd or even) to find the cleanest frequency channel by setting jumper J2 odd/even scan select on the **Free Channel Search** module.

**NOTE:** *The Free Channel Search module is set at the factory to work with the scan RF module in the receiver. If changes are made to the Free Channel Search module, the same changes must be made to the scan RF module in the receiver.*

Use Figure 3.20: Free Channel Search Module to locate the jumpers on the **Free Channel Search** module.

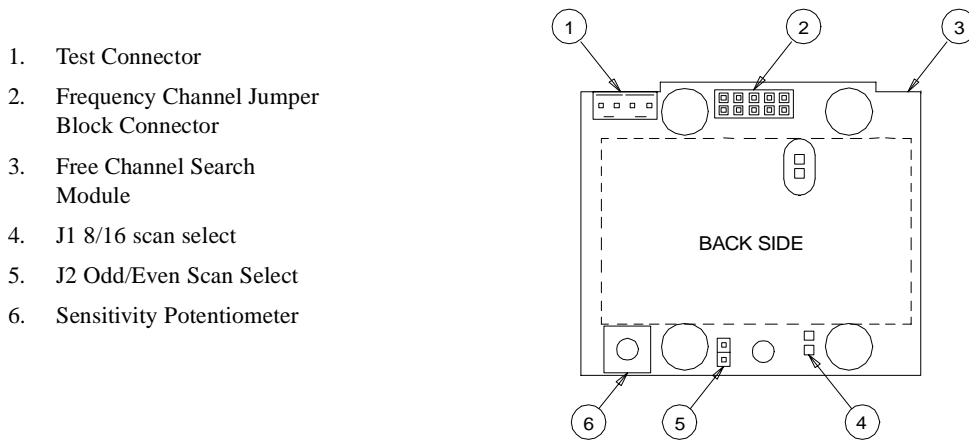

**Figure 3.20: Free Channel Search Module**

1. Make sure the transmitter is off. Remove the key to be sure.
  2. Remove the battery from the transmitter, refer to Battery and Charger Information later in this section.
  3. Access the inside of the PulseStar•610 transmitter by removing the four screws which hold the upper housing and lower housing together.
  4. Remove the **Free Channel Search** module from the RF module.
    - Remove the screw which holds the **Free Channel Search** module to the stand-off.
    - Unplug the **Free Channel Search** module from the RF Module Frequency Channel Jumper Block.
  5. Access the back side of the **Free Channel Search** module and locate the configuration jumpers.
  6. Set the jumpers to scan for the frequency channels used by the receiver.
    - Solder jumper J1 selects either 8 channel or 16 channel scan. When solder jumper J1 is open, it scans for 8 channels. When closed it scans 16 channels. Factory setting is for 8 channel scan.
    - Jumper J2 is the odd/even channel scan select. When jumper J2 is closed, it scans for odd channels (1, 3, 5, 7, 9, 11, 13, 15). When open it scans for even channels (0, 2, 4, 6, 8, 10, 12, 14).
- NOTE: When solder jumper J1 is set for 16 channel scan, jumper J2 is ignored.*
7. When finished, attach the **Free Channel Search** module to the RF module, replace the screw holding the **Free Channel Search** module to the stand-off, and close the transmitter by mating the lower and upper halves and inserting the four screws.

# Battery and Charger Information

## Removing and Inserting the Battery From the Transmitter

### JRT Transmitter

To remove or insert the battery from the JRT transmitter, refer to Figure 3.21: JRT Transmitter Battery Removal.

**Removal:** Push the battery toward the spring-loaded contacts. Tilt the battery away from the housing until the battery pops out of the compartment.

**Insertion:** Place the battery in the battery cavity at an angle, with the end containing the gold plated contacts facing the spring-loaded contacts. Push battery into the battery cavity and against the spring loaded contacts until the battery can be placed flush against the battery cavity wall. The battery should now be securely positioned inside the battery cavity.

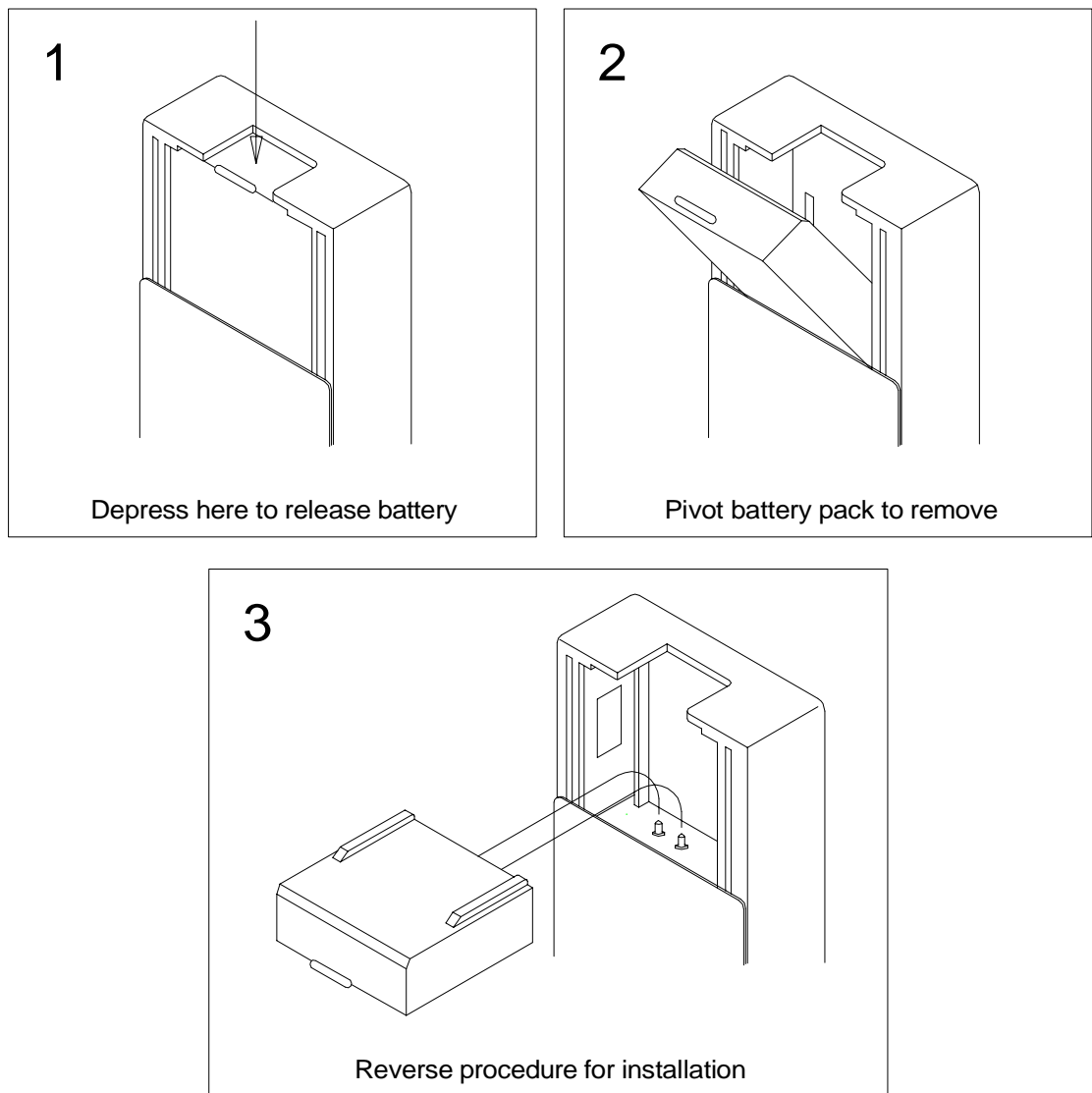

Figure 3.21: JRT Transmitter Battery Removal

## PBT Transmitter

To remove or insert the battery from the PBT transmitter, refer to Figure 3.22: PBT Transmitter Battery Removal.

**Removal:** Push the battery tab toward the battery. Pivot the battery away from the housing until the battery pops out of the compartment.

**Insertion:** Locate the two battery hinges on the battery. They are opposite the battery tab. Line up the battery hinges with the corresponding hinge guides in the battery cavity wall of the transmitter. Place the battery, hinge side first, into the battery cavity and slide the battery hinges into the hinge guides. Slowly press downward on the battery until the battery tab locks into place.

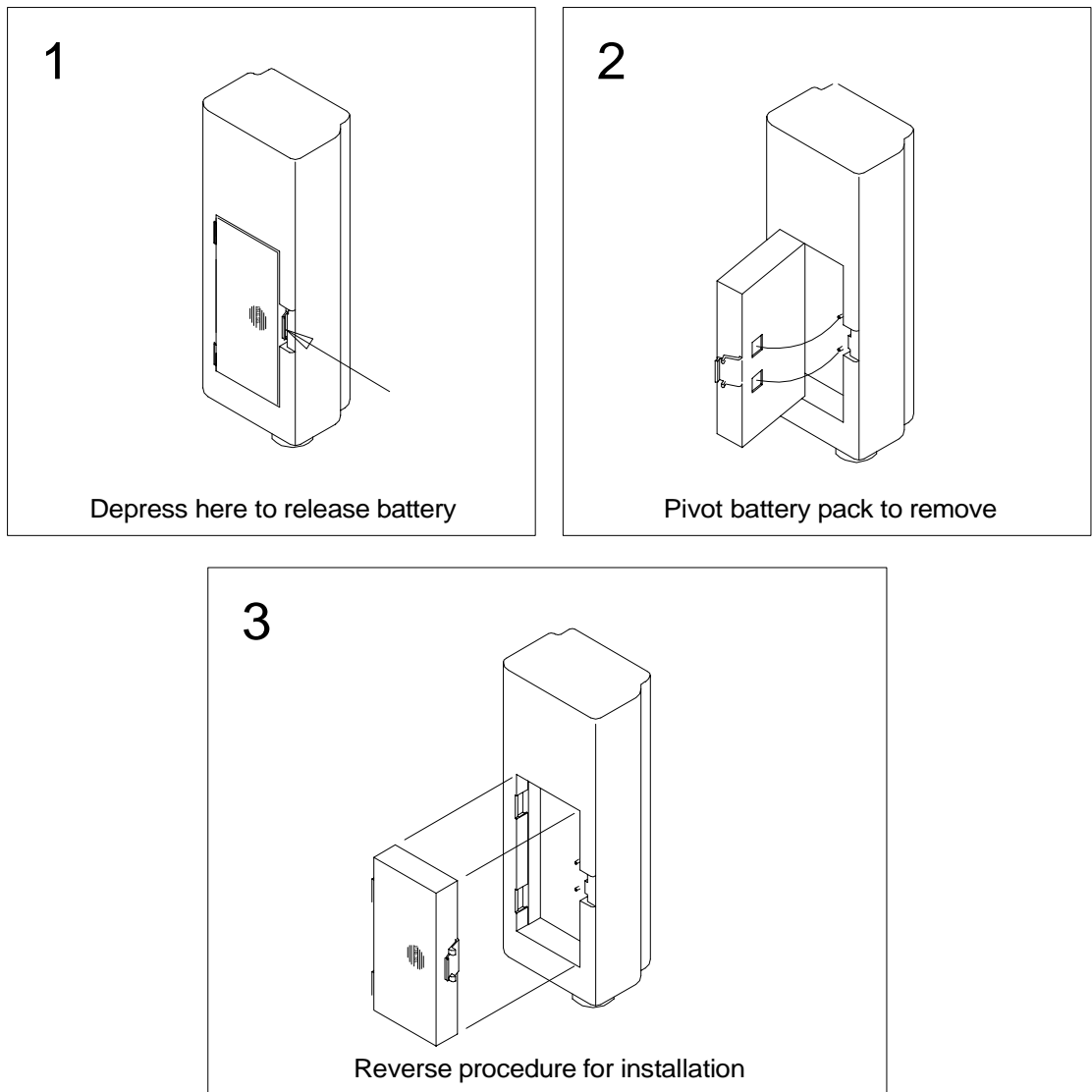

*Figure 3.22: PBT Transmitter Battery Removal*

## NVT Transmitter

To remove or insert the battery from the NVT transmitter, refer to Figure 3.23: NVT Transmitter Battery Removal.

**Removal:** Push the battery toward the spring-loaded contacts. Tilt the battery away from the housing until the battery pops out of the compartment.

**Insertion:** Place the battery in the battery cavity at an angle, with the end containing the gold plated contacts facing the spring-loaded contacts. Push battery into the battery cavity and against the spring loaded contacts until the battery can be placed flush against the battery cavity wall. The battery should now be securely positioned inside the battery cavity.

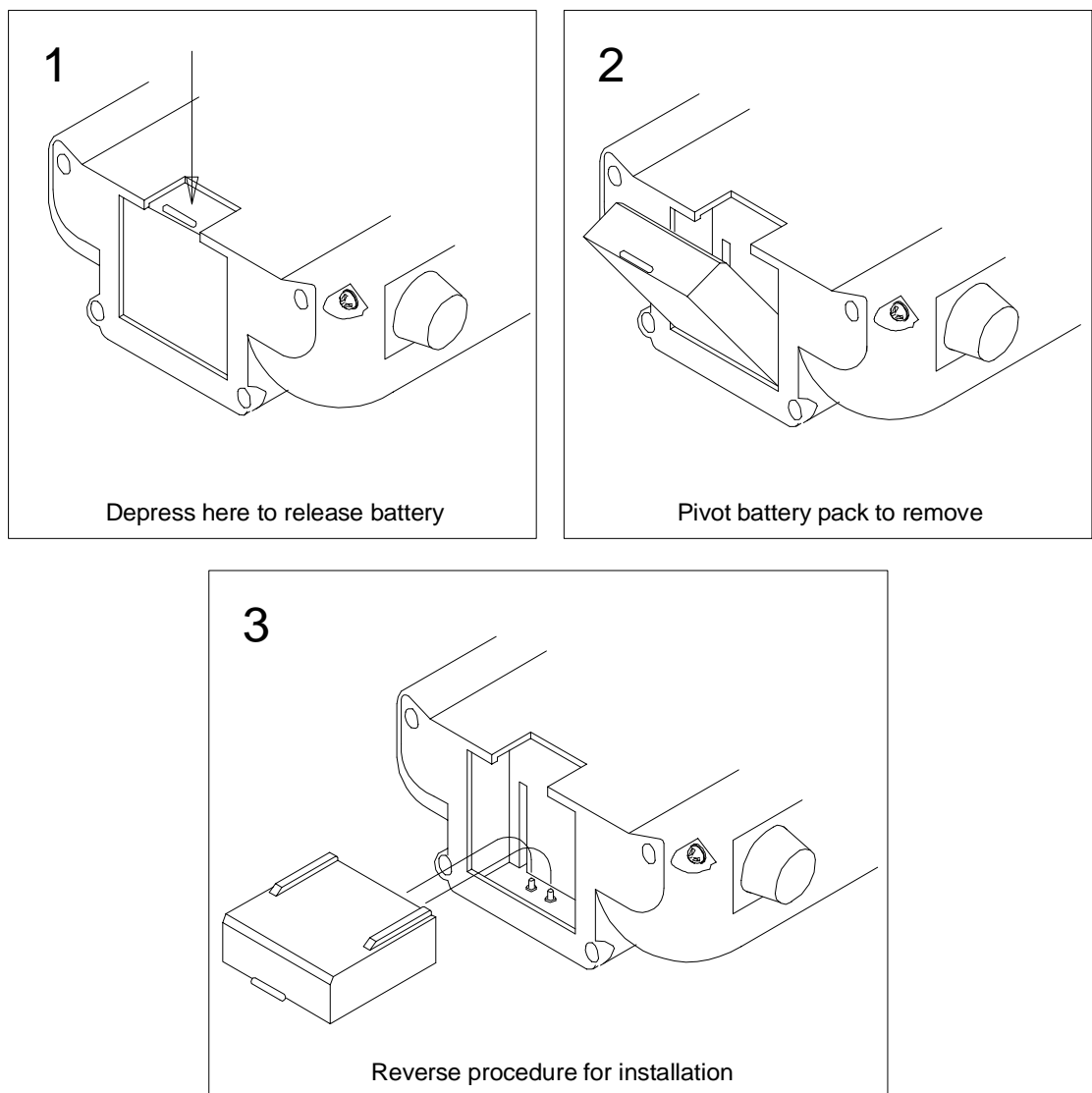

*Figure 3.23: NVT Transmitter Battery Removal*

## GLT Transmitter

To remove or insert the battery from the GLT transmitter, refer to Figure 3.24: GLT Transmitter Battery Removal.

**Removal:** Push the battery tab toward the battery. Pivot the battery away from the housing until the battery pops out of the compartment.

**Insertion:** Locate the two battery hinges on the battery. They are opposite the battery tab. Line up the battery hinges with the corresponding hinge guides in the battery cavity wall of the transmitter. Place the battery, hinge side first, into the battery cavity and slide the battery hinges into the hinge guides. Slowly press downward on the battery until the battery tab locks into place.

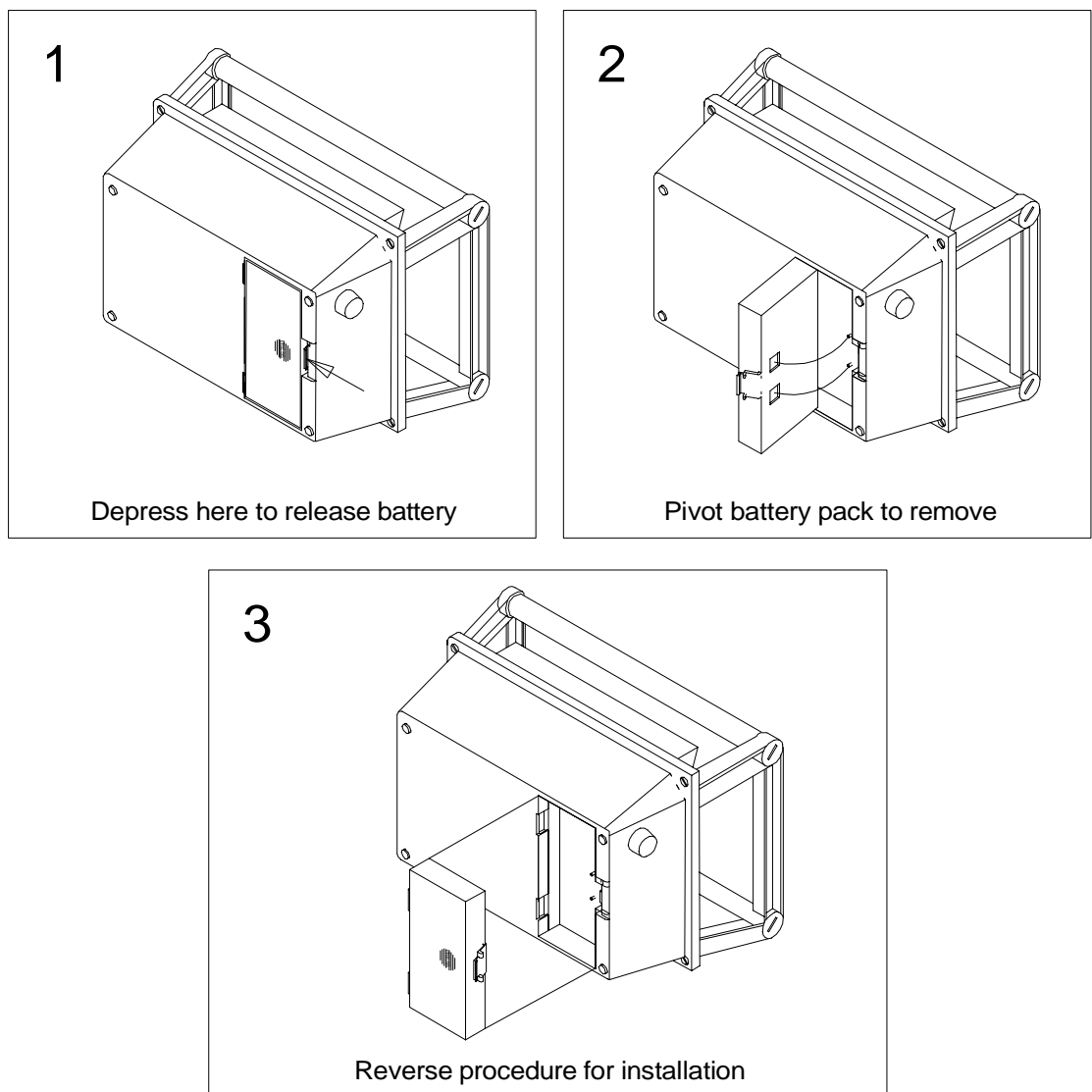

*Figure 3.24: GLT Transmitter Battery Removal*

## GRT Transmitter

To remove or insert the battery from the GRT transmitter, refer to Figure 3.25: GRT Transmitter Battery Removal.

**Removal:** Push the battery tab toward the battery. Pivot the battery away from the housing until the battery pops out of the compartment.

**Insertion:** Locate the two battery hinges on the battery. They are opposite the battery tab. Line up the battery hinges with the corresponding hinge guides in the battery cavity wall of the transmitter. Place the battery, hinge side first, into the battery cavity and slide the battery hinges into the hinge guides. Slowly press downward on the battery until the battery tab locks into place.

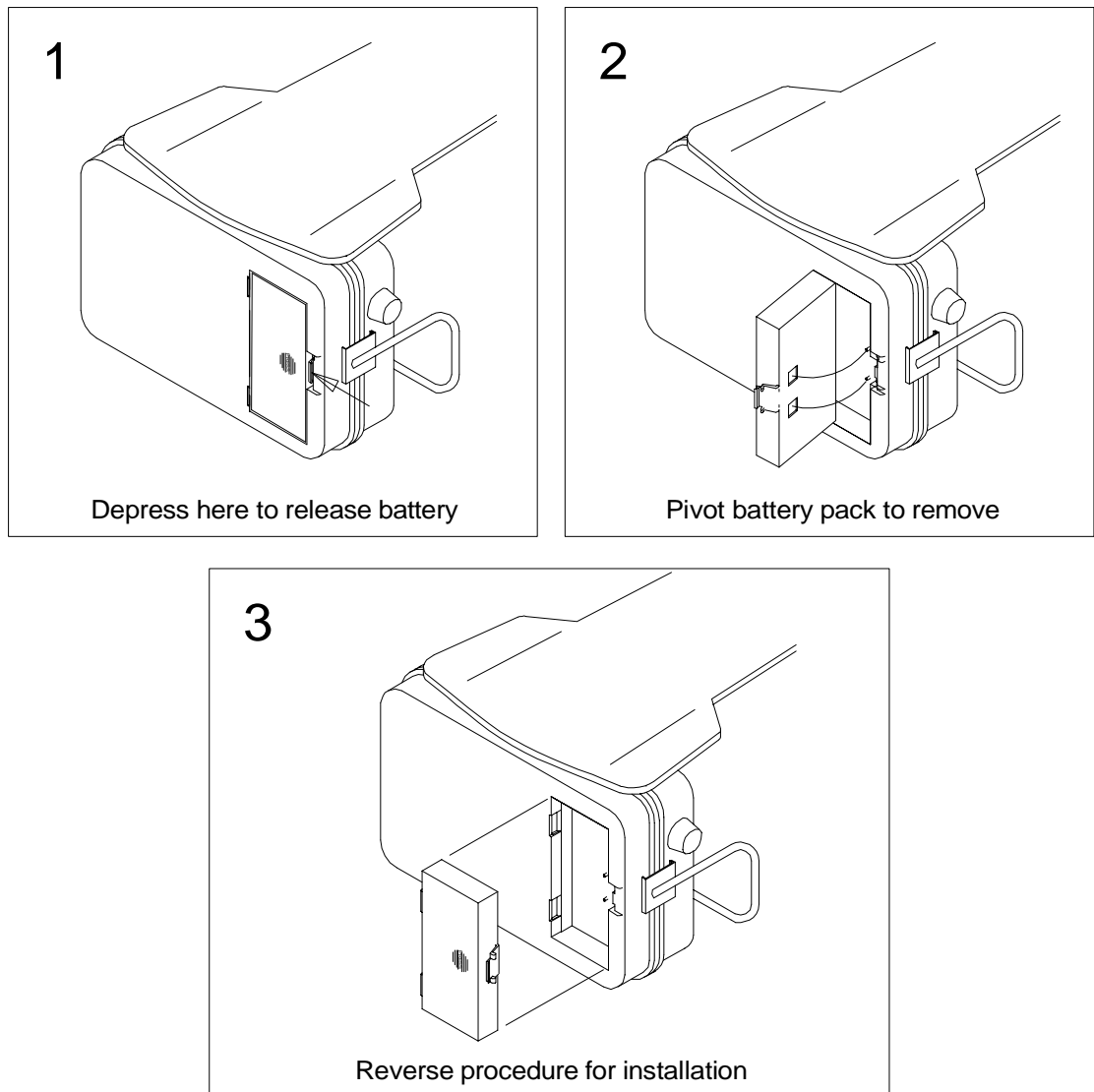

*Figure 3.25: GRT Transmitter Battery Removal*

## Charging the Battery

The PulseStar battery charger is designed for 115/230VAC and plugs into a regular wall outlet. Please refer to Figure 3.26: Battery Charger for JRT, NVT Transmitters and Figure 3.27: Battery Charger for PBT, GLT, GRT Transmitters for charger layout.

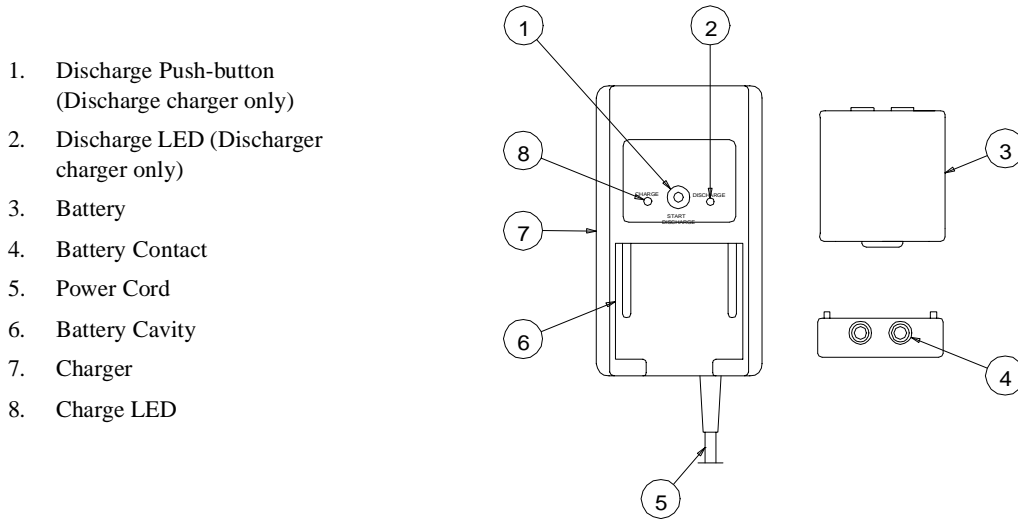

*Figure 3.26: Battery Charger for JRT, NVT Transmitters*

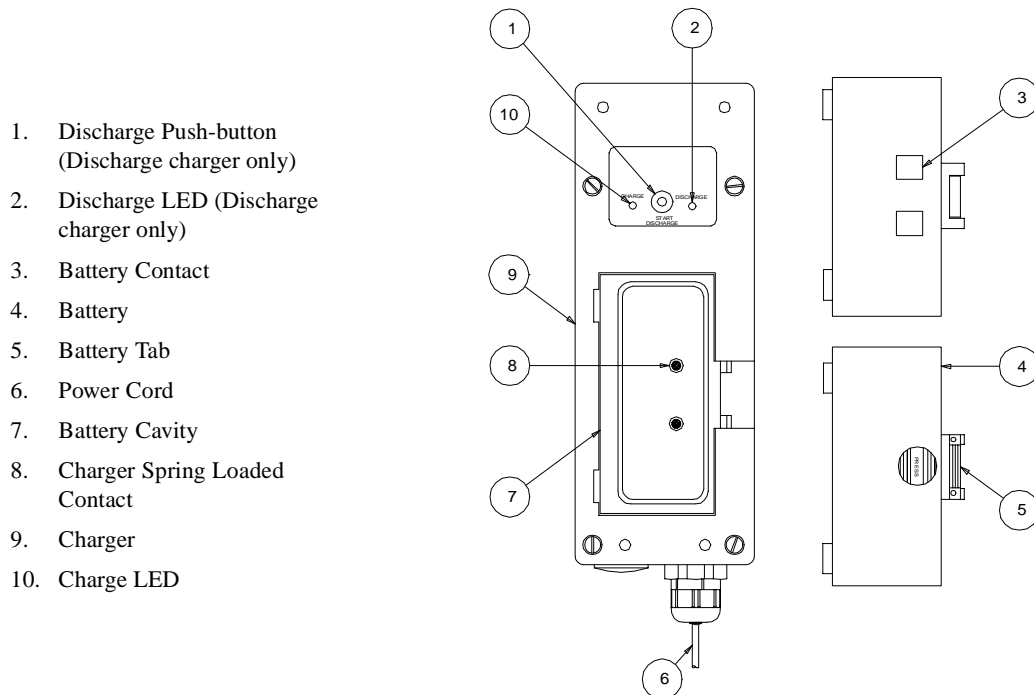

*Figure 3.27: Battery Charger for PBT, GLT, GRT Transmitters*

## Standard Charger

Insert the battery into the charger. The green charge LED emits a steady light to indicate that the battery is being charged.

The processor in the charger checks the capacity of the battery until the battery is fully charged. The maximum charging time is four hours. When the battery is fully charged, the green charge LED begins to flash. Leave the battery in the charger until needed to ensure it is fully-charged.

If the power supply to the charger is interrupted, or the battery is removed and then reinserted into the charger (before the battery was fully charged), the charger detects how much charge the battery has left and resumes the charging process.

## Discharge Charger

Insert the battery into the charger. The green charge LED emits a steady light to indicate that the battery is being charged. Press the red Start Discharge push-button. The green charge LED turns off, and the red discharge LED turns on. The battery will now fully discharge. Once the battery is fully discharged, the red discharge LED will turn off, and the green charge LED will turn on. The green charge LED emits a steady light to indicate that the battery is being charged.

The processor in the charger checks the capacity of the battery until the battery is fully charged. The maximum charging time is four hours. When the battery is fully charged, the green LED begins to flash. Leave the battery in the charger until needed to ensure it is fully-charged.

The following table summarizes battery information for JRT and NVT transmitters.

Charging Time	4 hours (from fully discharged)
Operation Time	7–10 hours continuous
Type	Nickel Metal Hydrite; 9.6 Volts, 750 milliamperere hours
Maximum number of charges	Approximately 800 times

The following table summarizes battery information for PBT, GLT and GRT transmitters.

Charging Time	4 hours (from fully discharged)
Operation Time	7–10 hours continuous
Type	Nickel Cadmium; 9.6 Volts, 600 milliamperere hours
Maximum number of charges	Approximately 800 times

**NOTE:** *A long life Nickel Cadmium battery is available for the PBT, GLT and GRT transmitters. Operation time is 12-14 hours, and the capacity is 1000mAH.*

All charger and battery contacts are gold-plated to provide superior contact. Batteries and chargers are IP65-rated. The mechanical design of the battery case and the battery pocket ensures that each insertion and removal of the battery will clean the contacts. This is known as “self-cleaning” contacts.

## Memory Effect

To maximize the lifetime of your battery, **only charge completely discharged batteries** whenever possible. Charging a partially discharged battery may result in a memory effect in the battery, which reduces the number of times it can be effectively charged.

*c h a p t e r* **4**

---

**Troubleshooting  
PulseStar•610**

This page intentionally left blank.

# Troubleshooting

## Introduction

This chapter covers what to do if the PulseStar•610 does not seem to work properly. If you are unable to resolve the problem after using this section, contact Electromotive Systems immediately at 1-800-288-8178.



### WARNING

- Only authorized personnel are permitted to perform the initial setup or service work. Use only Electromotive Systems parts.
- Do NOT touch any circuit components on the circuit board while the main AC or DC power is on.
- Do NOT change the address code settings in the receiver.

## Common Problems

The following are common problems associated with using the PulseStar•610 system, and their possible solutions. For help in diagnosing problems in the receiver, refer to the drawing in the Start-up and Test Procedures section in chapter 2 that shows the location of each diagnostic LED.

**Problem: The transmitter is turned on, but it does not broadcast (Power LED not flashing).**

### Possible Solution(s):

- Battery is dead. Replace with fully charged battery.
- Fuse located on coder board is blown. Check fuse and replace if blown.
- Key switch is broken. Check wiring to the key switch contact element. Replace key switch wiring or contact element.
- The coder board has failed. Contact Electromotive Systems.

**Problem: The transmitter is broadcasting, but all crane motions are not working.**

### Possible Solution(s):

- The **Active E-STOP** push-button is activated (pushed in). Pull out the **Active E-STOP** push-button and press the **START/HORN** push-button.
- Transmitter is out of range (328 feet typical). Bring the transmitter back into range, and press the **START/HORN** push-button.
- A crane motion function was not 'off' when transmitter was turned on. Make sure all joysticks, paddle levers, push-button, etc. are in the center (off) position. Cycle transmitter power (turn off and then on) and press the **START/HORN** push-button.
- Incoming power to receiver is off. Turn on power to receiver.
- Fuse is blown in receiver. Check all line fuses and power pack fuses. Replace any blown fuses.

- Receiver is set for different frequency channel. If green Telegram LED located on the decoder board is not flashing, check that the receiver frequency channel matches that of the transmitter.

**NOTE:** *Always match the transmitter frequency channel to the receiver. Never change the receiver frequency channel without consulting Electromotive Systems first.*

- Receiver is set for different address code. Check to make sure the address code on the decoder board and **Active E-STOP** stop decoder board matches the address code of the transmitter.

**NOTE:** *Always match the transmitter address code to the receiver. Never change the receiver address code without consulting Electromotive Systems first.*

- **Active E-STOP** failure in transmitter. Check **Active E-STOP** push-button for damage. Check wiring to **Active E-STOP** push-button contact element for broken or disconnected wire(s). Replace broken wire(s) or **Active E-STOP** push-button.
- **Active E-STOP** failure in the receiver. Check red **Active E-STOP** LED on decoder board. If it is illuminated:
  - Check to make sure the address code is the same on the decoder board and the **Active E-STOP** decoder board. If they are different consult Electromotive Systems for correct address code and set both the decoder board and **Active E-STOP** decoder board to the correct address code.
  - Wire may have come disconnected from the **Active E-STOP** module, decoder module, or **Active E-STOP** decoder module. Check for loose wiring.
  - **Active E-STOP** module has failed. Replace the **Active E-STOP** module.

**Problem: All crane motions work intermittently.**

**Possible Solution(s):**

- Antenna on receiver is loose or has fallen off. Tighten or replace antenna.
- External antenna (when used) is loose, poorly grounded, or receiving interference. See Connecting a Standard External Antenna section in Chapter 2.
- Surge suppressors are not installed on contactors being controlled by the receiver. Make sure all contactors being controlled by the receiver have surge suppressors installed.
- Control wiring may be combined with power wiring. Make sure that all control wiring is separate from power wires.
- Connector inside receiver has come loose. Check all Dubox (blue) connectors.

**Problem: Some crane motions work intermittently.**

**Possible Solution(s):**

- Wiring may be loose to that crane motion. Check wiring from the receiver to the quick disconnect plug, and check wiring from quick disconnect plug to crane motion.
- Connector inside receiver has come loose. Check all Dubox (blue) connectors.
- Surge suppressors may not be installed on contactors controlling that crane motion. Make sure all contactors being controlled by the receiver have surge suppressors installed.
- Control wiring may be combined with power wiring. Make sure that all control wiring is separate from power wires.

**Questions to Ask**

When reporting a problem to Electromotive Systems you may be asked several questions pertaining to the PulseStar•610 system. Asking these questions to the person who reported the problem prior to calling Electromotive Systems will speed up the troubleshooting process.

**Transmitter**

- Is the **Active E-STOP** push-button pulled out?
- Is the key switch in the ON position?
- Did you press the **START/HORN** push-button?
- Are the joysticks, switches, and push-buttons in the center (off) position?
- Did you press the **START/HORN** push-button while accidentally holding in one of the other push-buttons?
- Is there a charged battery installed?
- Did you take the transmitter out of its operating range (328 feet)?

**Receiver**

Open the cabinet enclosure where the receiver circuit board is installed and check the following. Refer to the drawing in the Start-up and Test Procedures section in chapter 2 that shows the location of each diagnostic LED.

- Is the CPU Standby LED flashing?
- Is the Telegram LED flashing?
- Is the **Active E-STOP** LED lit on either the decoder module or **Active E-STOP** decoder module?
- Are the connections/screw terminals tight?
- Check the antenna plug for a secure connection.
- Check the antenna connection assembly outside the enclosure.
- Check the power supply and ground wires.
- Are the signal wires separated from the power wires?
- Are surge suppressors installed on all magnetic contactors being controlled by the receiver?

This page intentionally left blank.

*a p p e n d i x* **A**

---

**Definitions and Abbreviations**

This page intentionally left blank.

# Definitions and Abbreviations

## Definitions

The following terms are used throughout the *PulseStar•610 Instruction Manual* and may be unfamiliar to some operators.

<b>Term</b>	<b>Definition</b>
analog	Proportional-stepless or infinite control
baud	The transmitting speed measured in bits per second
decoder	Converts a serial data message into parallel signals
double superheterodyne	A method to build an extremely narrow band receiver by converting the receiver frequency twice.
coder	Converts parallel signals into a serial data message
hamming distance	A measurement of data transmission safety. The amount of failures in the data stream which has to occur during the transmission in order to create a wrong signal. A low hamming distance means that the test is not very sensitive to data transmission errors and could be potentially unsafe. A high hamming distance means that the system is very sensitive and could potentially be unreliable due to potential noise interference.
latching	The auxiliary function will turn on when the operator presses option button once and releases it (PBT) or flips the spring return switch up (NVT, GLT, GRT). The auxiliary function will not turn off until the operator presses the option button a second time (PBT) or flips the spring return switch (NVT, GLT, GRT).
maintained	The auxiliary function will turn on when the operator flips the maintained switch to the appropriate position (NVT, GLT, GRT). The auxiliary function will turn off as soon as the operator flips the maintained switch to the off position (NVT, GLT, GRT).
momentary	The auxiliary function will turn on when the operator presses the option button and holds it down (PBT) or flips the spring-return switch and holds it up (NVT, GLT, GRT). The auxiliary function will turn off as soon as the operator releases the option button (PBT) or releases the spring-return switch (NVT, GLT, GRT).
synthesizer technology	Used to electronically generate a carrier frequency.

## Commonly Used Abbreviations

<b>Abbreviation</b>	<b>Meaning</b>
A/D	Analog to digital conversion
AK	Analog channel (German: Analog Kanal)
AMP	Ampere
AWG	American wire gauge
BPS	Bits per second
DK	Digital channel (German: Digital Kanal)
EMC	Electromagnetic compatibility
EMI	Electromagnetic immunity
EPROM	Electrical programmable read-only memory
FM	Frequency modulation

<b>Abbreviation</b>	<b>Meaning</b>
GND	Ground
HF	High frequency
KHz	Kilohertz
mAH	Milliampere hours
mA	Milliampere
msec	Millisecond
MHz	Megahertz
mW	Milliwatt
NiCd	Nickel cadmium
NiMH	Nickel Metal Hydrite
PLC	Programmable logic controller
PLL	Phased locked loop
PWM	Pulse width modulation
RF	Radio frequency (same as HF - high frequency)
RMS	Root mean squared
Rx	Receiver
RxD	Receiving data
SMD	Surface mount device
SMT	Surface mount technology
TTL	Transistor transistor logic
Tx	Transmitter
TxD	Transmitting data
Ub	Operating power
Uv	Microvolts
VAC	Volts (alternating current)
VDC	Volts (direct current)

*a p p e n d i x* **B**

---

**Specifications**

This page intentionally left blank.

# Specifications

## System Specifications

<b>Specification</b>	<b>Setting</b>
Certification	TÜV and CE
Temperature range	-18°F to 158°F (-25°C to 70°C)
Operating range	330 feet (100 meters) typical
Humidity range	0-95% maximum non-condensing
Modulation	Narrow band - FM
Frequency range	400 - 470 MHz (16 preset frequencies)
Bandwidth	12.5 kHz/25kHz
Frequency generation	Microprocessor controlled PLL Synthesizer
Microprocessor	80C31 Intel
Baud rate	4800 bps (approx. 55 msec response time)
Hamming distance	4
Security	16-bit addressing (more than 65,000 possibilities)

## JRT Specifications

<b>Specification</b>	<b>JRT</b>
Weight	Less than 1.5 lbs (including battery)
Physical size (LxWxH)	7.8" x 3.4" x 1.4" (19.8 cm x 8.6 cm x 3.6 cm)
HF output power	Maximum 10 mW
Deviation	±2kHz
Power supply	9.6-V Nickel Metal Hydrite rechargeable battery; 750 milliamp-hours
Operation time	7–10 hours continuous with one charge
Enclosure	IP65 Weatherproof (exceeds NEMA 12/13)
Protection	Key switch with cap
Antenna	Built-in
Functions	Emergency-stop button (push/pull) 3 crane motions 2 speeds, interlocked 1 crane motion 1 speed Horn and mainline activation Option push-button
Features	Sleep mode (10 minutes) Switch-ON protection Mechanical protection against accidental activation
Battery charger	115/220VAC (±20%) Charging time—4 hours Gold plated and self-cleaning contacts 2 batteries included

## PBT Specifications

<b>Specification</b>	<b>PBT</b>
Weight	<1.75 pounds (including battery)
Physical size (LxWxH)	9.25" x 3.42" x 2.3" (23.5cm x 8.7cm x 5.8cm)
HF output power	max 10 mW
Deviation	+/- 2kHz
Power supply	9.6 V Nickel Cadmium rechargeable battery
Operation time	7-10 hours continuous with one charge
Enclosure	IP65 Weatherproof (better than NEMA 12/13)
Protection	Key switch with cap
Antenna	Built-in
Functions	Emergency-stop button (push/pull) 4 crane motions 2 speeds, interlocked Horn and mainline activation Option button 2 Selector buttons (PBT-5A only)
Features	Sleep mode (PBT-4 only) Switch on protection Electrical interlocking of crane motions Mechanical protection against accidental activation
Battery charger	115/220 VAC (+/- 20%) Charging time - 3 hours Gold plated and self-cleaning contacts 2 batteries included

## NVT Specifications

Specification	NVT
Weight	<2 pounds (including battery)
Physical size (LxWxH)	9.3" x 4" x 6.4" (23.6cm x 10.2cm x 16.3cm)
HF output power	max 10 mW
Deviation	+/- 2kHz
Power supply	9.6 V Nickel Metal Hydrite rechargeable battery
Operation time	7-10 hours with one charge
Enclosure	IP65 Weatherproof (better than NEMA 12/13)
Protection	Key switch with cap
Antenna	Built-in
Functions	Emergency-stop button (push/pull) 6 or more crane motions Fully-proportional with 8-bit resolution (256 increments for each crane motion activated by joystick and/or lever masters or up to 3 discreet speeds activated by joystick) Horn and mainline activation Toggle switch for auxiliary function (latching or non-latching) (example, micro-positioning) Hoist selector switch (A-A+B-B) where applicable Can be custom designed to suit the needs of special applications with a wide variety of master switches, toggles, selector switches, lights, etc.
Features	Sleep mode (10 minutes) Switch on protection Mechanical protection against accidental activation
Battery charger	115/220 VAC (+/- 20%) Charging time - 4 hours Gold plated and self-cleaning contacts 2 batteries included

## GLT Specifications

Specification	GLT
Weight	<4.4 pounds (including battery)
Physical size (LxWxH)	11.7" x 7" x 4.3" (29.7cm x 17.8cm x 10.9cm)
HF output power	approximately 10 mW
Deviation	+/- 2kHz
Power supply	9.6 V Nickel Cadmium rechargeable battery
Operation time	7-10 hours continuous with one charge
Enclosure	IP65 Weatherproof (better than NEMA 12/13) Explosion-proof enclosures available
Protection	Key switch with cap
Antenna	Built-in
Functions	Emergency-stop button (push/pull) 7 or more crane motions Fully-proportional with 8-bit resolution (256 increments for each crane motion activated by joystick and/or lever masters or up to 6 discreet speeds activated by joystick) Horn and mainline activation Toggle switch for auxiliary function (latching or non-latching) (example, micro-positioning) Hoist selector switch (A-A+B-B) where applicable Can be custom designed to suit the needs of special applications with a wide variety of master switches, toggles, selector switches, lights, etc. Available with LCD for remote readout of weights, diagnostics, etc.
Features	Sleep mode (10 minutes) Switch on protection Mechanical protection against accidental activation
Battery charger	115/220 VAC (+/- 20%) Charging time - 3 hours Gold plated and self-cleaning contacts 2 batteries included

## GRT Specifications

Specification	GRT
Weight	<12 pounds (including battery)
Physical size (LxWxH)	12" x 8" x 8" (overall height with the breast plate is 15.5") (30.5cm x 20.3cm x 20.3cm)
HF output power	approximately 10 mW
Deviation	+/- 2kHz
Power supply	9.6 V Nickel Cadmium rechargeable battery
Operation time	7-10 hours continuous with one charge
Enclosure	IP65 Weatherproof (better than NEMA 12/13) Explosion-proof enclosures available
Protection	Key switch with cap
Antenna	Built-in
Functions	Emergency-stop button (push/pull) 7 or more crane motions Fully-proportional with 8-bit resolution (256 increments for each crane motion activated by joystick and/or lever masters or up to 6 discreet speeds activated by joystick) Horn and mainline activation Toggle switch for auxiliary function (latching or non-latching) (example, micro-positioning) Hoist selector switch (A-A+B-B) where applicable Can be custom designed to suit the needs of special applications with a wide variety of master switches, toggles, selector switches, lights, etc.
Features	Sleep mode (10 minutes) Switch on protection Mechanical protection against accidental activation
Battery charger	115/220 VAC (+/- 20%) Charging time - 3 hours Gold plated and self-cleaning contacts 2 batteries included

## Receiver Specifications

Specification	GA610
Operating power	50/110/240 VAC 50/60Hz (+/- 20%) or 12/24 VDC (+/- 50%)
Current	<100 mA
HF part	Double Superheterodyne
Sensitivity	0.4 microvolts (Root Mean Squared)
Safety	Self-monitoring emergency circuitry Fail-safe, spring-forced Emergency-stop relay Self-test during start-up and operation
Diagnostic	On-board diagnostic system with indicators for: RF communication, power status, active outputs
Output	1 Emergency-Stop relay, 275 VAC 8 Amp/30 VDC 5 Amp 1 Horn relay - normally open, 275 VAC 8 Amp/30 VDC 5 Amp 1 Start/Mainline relay - normally open, 275VAC 8 Amp/30 VDC 5 Amp 1 Auxiliary relay - normally open, 275VAC 8 Amp/30 VDC 5 Amp Up to 32 digital outputs DC applications up to 250 VDC 2.5 Amp Up to 8 proportional outputs (0-10 volts DC, 4-20 milliamperes, 0-20 volts AC, etc)

This page intentionally left blank.

*a p p e n d i x* **C**

---

**StarService and Warranty**

This page intentionally left blank.

# StarService Policy

This chapter includes information pertaining to on-call service, transmitter loaner and Repair program, and Receiver Replacement/Repair Program warranty. Before you install, troubleshoot, or service the radio control system, we highly recommend that you read this entire chapter. Doing this will help assure quick service response, minimize your on-site repair costs, and reduce crane downtime.

## On-Call Service

If you ever have a problem with your PulseStar•609 system, call Electromotive Systems at 1-800-288-8178. Technical support is available 24 hours a day, seven days a week. If necessary, Electromotive Systems can arrange to have a service technician visit your site to evaluate the situation (normally at your expense.)

## Warranty

Every PulseStar product includes a two-year warranty from the date of shipment. The warranty is described in detail later in this chapter.

## Transmitter Loaner, Replacement & Repair Program

The PulseStar Transmitter Loaner, Replacement & Repair Program provides a replacement transmitter, or loaner transmitter while your transmitter is being repaired. Under the terms of the Loaner, Replacement and Repair Program, please provide a purchase order or credit card to cover the cost of the loaner transmitter.

*NOTE: The PulseStar•610 systems are engineered to order. Because of this it is often not possible to provide a loaner or replacement transmitter with the identical functionality of the transmitter being submitted for repair. On some occasions a loaner or replacement transmitter will not be available because of the complexity of the application.*

If you need to return a defective transmitter, please follow the steps below.

1. Request a Return Authorization (RA) from Electromotive Systems' Service Department and return the defective transmitter to Electromotive Systems **via pre-paid freight. When you call, please have the information from the serial nameplate of the transmitter available.**
2. Electromotive Systems will ship a loaner or replacement transmitter within 24 business hours.
3. Electromotive Systems will inspect the defective transmitter and determine if the defects are covered under warranty. If the defects are covered under warranty, Electromotive Systems, at their discretion, will do one of the following:
  - Replace the defective transmitter with the loaner or equivalent transmitter. The replacement transmitter will be covered for the duration of the original transmitter warranty period.
  - Credit the full cost of the loaner transmitter, plus pay for all freight charges for both the loaner transmitter and the transmitter repaired under warranty.

*NOTE: Freight charges incurred from sources other than common ground carriers **WILL NOT** be reimbursed unless pre-approved by Electromotive Systems.*

- If the defects are not covered under warranty, Electromotive Systems will credit the cost of the loaner transmitter, less the cost of the repairs, a \$50 loaner inspection fee, and any freight charges incurred by Electromotive Systems.

4. Electromotive Systems will repair or replace the transmitter. Repaired transmitters will be shipped from Electromotive Systems within 72 business hours of receipt of transmitter (three working days).
5. If the original transmitter is repaired, return the loaner transmitter in good condition to Electromotive Systems **via prepaid freight**.

## **Receiver Repair Program**

The process for returning a defective PulseStar•609 receiver is described in the following steps.

1. Request a Return Authorization (RA) from Electromotive Systems' Service Department and return the defective receiver to Electromotive Systems via prepaid freight. You are responsible for the shipping charges for sending the defective parts to Electromotive Systems.
2. Electromotive Systems will inspect the receiver and determine if the defects are covered under warranty.
  - If the defects are covered under warranty, Electromotive Systems will repair the receiver at no cost, and credit the full cost of all freight charges.

***NOTE: Freight charges incurred from sources other than common ground carriers WILL NOT be reimbursed unless pre-approved by Electromotive Systems.***
  - If the defects are not covered under warranty, you are responsible for the cost of the repairs and all freight charges.

# Limited Warranty And Terms Of Sale

**Prices:** Subject to Change Without Notice  
**Terms:** Net 30 Days

**F.O.B.** Electromotive Systems, Inc.  
Milwaukee, Wisconsin

Electromotive Systems, Inc., hereafter referred to as Company, guarantees all items manufactured by it against any defects of material and/or workmanship for a period of two years from the date of shipment. Company makes **NO OTHER WARRANTY, EXPRESSED OR IMPLIED, AS TO THE MERCHANTABILITY OR FITNESS OF THE ITEMS FOR THEIR INTENDED USE OR AS TO THEIR PERFORMANCE.** Any statement, description or specification in Company's literature is for the sole purpose of identification of items sold by the Company and imparts no guarantee, warranty or undertaking by company of any kind. Components and accessories not manufactured by Electromotive Systems are not included in this warranty and are warranted separately by their respective manufacturers.

Company's sole liability shall be to repair at its factory, or replace any item returned to it within two years from date of shipment, which Company finds to contain defective material or workmanship. All items to be repaired or replaced shall be shipped to Company (Note: return authorization by Company is required) within said two year period, freight prepaid, as a condition to repair or replace defective material or workmanship. Company's herein assumed responsibility does not cover defects resulting from improper installation, maintenance, or improper use. Any corrective maintenance performed by anyone other than the Company during the warranty period shall void the warranty. Company shall not be liable for damages of any kind from any cause whatsoever beyond the price of the defective Company supplied items involved. Company shall not be liable for economic loss, property damage, or other consequential damages or physical injury sustained by the purchaser or by any third party as a result of the use of any Company supplied items or material.

Company neither assumes nor authorizes any other person to assume for Company any other liability in connection with the sale or use of items sold by Company.

List prices or discounts are subject to change without notice. Quoted prices will be honored for a period of 30 days from the date of the written quotation unless otherwise stated.

Orders of \$25,000 or more, and orders for special control panels are subject to special terms and conditions of sale. Refer to those specific sections within this document.

Orders are not subject to alteration or cancellation except upon written consent of Company and payment of proper cancellation charges, when deemed applicable by Company.

Materials or items may not be returned for credit, without the prior written consent of the Company. Any authorized return of materials or items shall be subject to a restocking charge equal to 20% of the net invoiced amount after Company determines that the material or item is in good condition and may be resold without alteration or service. If upon receipt of the material or items returned, the Company determines that said materials or items cannot be resold without alteration or service, the Company reserves the right to reject the returned materials or items and to send the same back to said purchaser at purchaser's expense.

Terms of payment are NET 30 days. All materials and items are sold F.O.B. Company's shipping point. Company retains a security interest in all items sold by it so long as they remain in Company's possession to secure all obligations of purchaser to Company. A processing fee will be applied to all invoices for requested prepaid freight charges other than UPS. A service charge will be incurred on past due accounts extending beyond the Terms of Sale described above, at a rate of 1.5 per month or a fraction thereof, of the net balance extending beyond 30 days..

Any claim for errors in shipment or for material or item shortages must be received by Company within 30 days of shipment and must be accompanied by copies of the bill of lading and packing slip.

## **Special Terms and Conditions: Orders of \$25,000 or More**

### **Electrification and Control Orders**

#### **Drawings and Drawing Approvals (if applicable)**

In most cases, Electromotive Systems will submit drawings for customer approval within 30 days after receipt of purchase order.

Customer drawing approval and Electromotive Systems credit approval is required before Electromotive Systems will proceed with parts procurement or assembly work.

#### **Progress payment**

25% of total order is required prior to shipment.

75% balance to be paid Net 30 days upon shipment of order.

#### **Customer Requested Changes**

Customer shall pay for any additional charges that may be incurred due to customer change orders as incurred.

#### **Cancellation Policy**

Cancellation fee of 10% of orders, plus all charges that may be incurred to-date of cancellation, will be applicable to all orders cancelled after receipt of order.

#### **Credit Approval**

All orders are subject credit approval by Electromotive Systems, Inc.

All items manufactured and offered for sale by Electromotive Systems, Inc. are subject to limited warranty and terms of sale. These special terms and conditions are part of the limited warranty and terms, and only supersede to take exception to said warranty and terms section of this document for a complete description.

## **Special Terms and Conditions: Orders for Special Control Panels**

### **Drawing and Drawing Approvals**

In most cases, Electromotive Systems will submit drawings for customer approval within 30 days after receipt of purchase order.

Customer drawing approval and Electromotive Systems credit approval is required before Electromotive Systems will proceed with parts procurement or assembly work.

#### **Progress payments**

25% of total net order is required upon drawing approval.

25% of total net order is required prior to shipment.

50% balance to be paid Net 30 days upon shipment of order.

#### **Customer Requested Changes**

Customer shall pay for any additional charges that may be incurred due to customer change orders as incurred.

**Cancellation Policy**

Cancellation fee of 10% of order, plus all changes that may be incurred to-date of cancellation, will be applicable to all orders cancelled after receipt of purchase order.

**Credit Approval**

All orders are subject to credit approval by Electromotive Systems, Inc.

All items manufactured and offered for sale by Electromotive Systems, Inc. are subject to limited warranty and terms of sale. These special terms and conditions are part of the limited warranty and terms, and only supersede to take exception to said warranty and terms as specifically outlined. Refer to limited warranty and terms section of this document for a complete description.

This page intentionally left blank.